

11

Section 11

Mechanical Performance

Mechanical Performance

To provide for improved confidence for the users of Strebord[®] Falcon Panel Products Ltd., have tested doorsets to the demanding mechanical performance requirements defined by reference to Chiltern Dynamics Classification for Service Life Test Programme CDTM01.

At the time of publication of this manual Falcon Panel Products Ltd., is the only supplier able to offer this certification.

To obtain CDTM01 related 'Q' Mark certification it is necessary to carry out cycling tests to the requirements of BS EN 1191 and Operating force tests in accordance with BS EN 12046-2 in addition to the DD171 (BS EN 1192) tests described by reference to page 11.2

Registration Certificate



BM TRADA
Enhanced Lifetime
Performance Scheme

Certificate Number 001

10 August 2010	10 August 2010	5 July 2012
Date of Initial Registration	Date of Last Issue	Date of Expiry

**This is to certify that the doors
shown on the accompanying schedule of**

Falcon Panel Products Ltd
Clock House
Station Approach
Shepperton
Middlesex TW17 8AN

*meet the requirements of the Chiltern Dynamics CDTM01 Testing
Programme and are registered within the
BM TRADA Certification Limited
scheme for Enhanced Lifetime Performance Doorsets*

The scope of the approval is shown in the Schedule
The company agrees to manufacture its products in accordance with the Scheme
requirements and to use the Scheme Mark in accordance with the Regulations



Signed on behalf of BM TRADA Certification Ltd
For verification of this certificate please visit www.bmtrada.com.

The use of the accreditation mark indicates accreditation in respect
of those activities covered by the accreditation certification 012

11/14/1 Issue September 2009. This certificate remains the property of
BM TRADA Certification Ltd. to whom it must be returned on request.

**Please refer to Falcon Panel Products Ltd.,
for full details of sizes and specifications covered by this certificate.**

Mechanical Performance

DD171 & BS EN 1192 Mechanical Testing:

When considering doorsets for public buildings there is a tendency to concentrate on particular performances e.g. fire performance, acoustic properties etc. This can lead to an oversight of the basic function of a doorset which is to provide a means for 'traffic' to pass from one side of a wall to the other.

To perform satisfactorily and to provide for other performances, the doorset must work reliably over a long period of time and often under conditions where the doorsets are subjected to abuse. If the door does not operate properly then all of the other performances that might otherwise be attributed to the particular location are likely to be undermined.

British Standard Draft for Development DD171 : 1987 provides a means for the mechanical testing of doorsets with the complete doorset being subjected to various levels of abuse to allow for the evaluation of mechanical performances.

More recently, European tests have been adopted that replace some of the mechanical tests described by reference to DD171. Where this has occurred, the EN tests are used but the DD171 tests have been retained in the United Kingdom where these have not been substituted by the European standards.

The following guidance is given to explain the grading system used by reference to DD171 for determining mechanical performances:

LD = Light Duty : Low frequency use by those with a high incentive to exercise care. e.g. by private house owners - small risk of accident occurring or abusive use.

MD = Medium Duty : medium frequency use primarily by those with some incentive to exercise care - some chance of accident occurring or mild abuse.

Comparisons of DD171 & BS EN 1192 Mechanical Tests.

		DD171				European Standards					
		Classification									
TEST	Test Ref.	LD	MD	HD	SD	TEST					Classification Document
<i>Slam shut test</i>	4.3	10 times	20 times	100 times	150 times	<i>No test</i>	n/a	n/a	n/a	n/a	n/a
<i>Slam open test</i>	4.4	5J	25J	50J	50J	<i>No test</i>	n/a	n/a	n/a	n/a	n/a
<i>Heavy body impact</i>	4.5	20J	40J	100J	150J	EN 949	30J	60J	120J	180J	EN 1192
<i>Hard body impact</i>	4.6	2J	3J	5J	8J	EN 950	1.5J	3J	5J	8J	EN 1192
<i>Torsion</i>	4.7	400N	400N	400N	400N	EN948	200N	250N	300N	350N	EN 1192
<i>Downward deflection</i>	4.8	500N	500N	500N	500N	EN947	400N	600N	800N	1000N	EN 1192
<i>Closure against obstruction</i>	4.9	200N	200N	200N	200N	<i>No test</i>	n/a	n/a	n/a	n/a	n/a
<i>Resistance to jarring</i>	4.1	50 Impacts	100 Impacts	150 Impacts	200 Impacts	<i>No test</i>	n/a	n/a	n/a	n/a	n/a
<i>Abusive force to handle</i>	4.11	750N	750N	750N	750N	<i>No test</i>	n/a	n/a	n/a	n/a	n/a



Certificate of Test: Chilt/P09071/Rev1

This certificate is awarded to:

Falcon Panel Products Ltd
 Clock House
 Station Approach
 Shepperton
 Middlesex
 TW17 8AN

This document confirms that performance testing was conducted from 13 August 2009 to 14 August 2009. Testing was conducted to the following standards:-
 • DD 171: 1987, Draft for development Guide to specifying performance requirements for hinged or pivoted doors,
 • BS EN 1192: 2000 Doors - Classification of strength requirements

Product tested	Falcon 44mm Strebord single leaf doorset
Summary of testing procedure	Result
DD171 Clauses 4.3, 4.4, 4.9, 4.10 and 4.11	Severe duty
EN947, EN948, EN949 and EN950 (classified to BS EN 1192)	Severe duty (Class 4)

The results relate only to the specimens tested, as detailed in the technical specification Chilt/P09071/tec1

Paul Andrews –
 Head of Section – Mechanical Testing
 Date: 7 June 2010

Vincent Kerrigan -
 Technical Manager
 Date: 09-06-2010

Chiltern Dynamics

Chiltern House, Stocking Lane, Hughenden Valley, High Wycombe, HP14 4ND, United Kingdom

Tel: 01494 569800 Fax: 01494 564895

Web: www.chilternfire.co.uk

Email: cdf@chilternfire.co.uk

Page 1 of 3



1762

This document is confidential and remains the property of Chiltern International Fire Ltd

HD = Heavy Duty : High frequency use by public and others with little incentive to exercise care. Risk of accident with probability of some abuse. e.g. offices, particularly offices open to the public.

SD = Severe Duty : High frequency use with risk of accidental damage and possibility of violent abusive usage. e.g. Hospitals, Educational Establishments.

NOTE: It is important to appreciate that DD171 and the related EN testing applies to the doorset as a whole i.e. including hardware.

The CDTM01 certificate reproduced on page 11.1 relates to the testing of a 44mm Strebord® based door in a Nom. 640kg/m³ hardwood frame and with hardware fixed using wood screws.

Hardware Enhanced fixing:

Notwithstanding the performance achieved by testing, the following is provided by way of guidance for consideration where additional reinforcement might be required to suit doorsets in locations that might be vulnerable to heavy impact attack.

Hinges & Hanging Devices: Whereas successful testing has been carried out using wood screws, the use of minimum 1 1/2 in. No. 10 fully threaded 'twinfast' or chipboard screws is recommended for the fixing of load bearing items of hardware to GDC (*graduated density chipboard*) door constructions. In any event, pilot holes should be drilled to receive screw fixings in both the door leaf and the frame.

Locks / Latches: Under heavy and abusive impact all wood door constructions may split at the lock / latch positions. The use of backplates with bolt through fixings. (e.g. ASSA 6650 leversets & ASSA 320 / 330 cylinder roses) is recommended to strengthen doors at these positions.

Recommended Lock / Latch fitting. Fig. 11.1

The use of backplates with bolt through fixings provide a means for clamping the door at lock / latch positions to improve resistance to splitting.

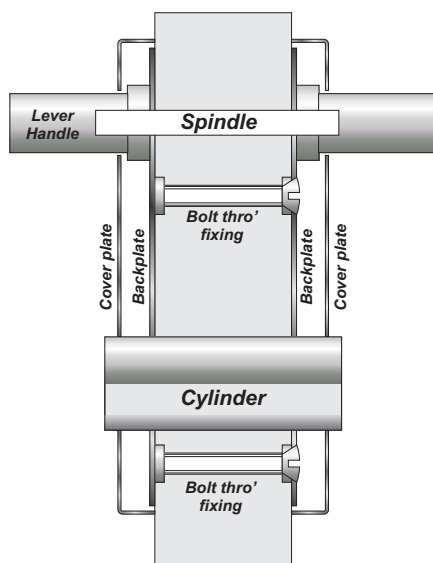

Concealed rod type Flush bolt. Fig. 11.2

The use of concealed rod type flush bolts provides for improved resistance to splitting when doors are subjected to impact forces.

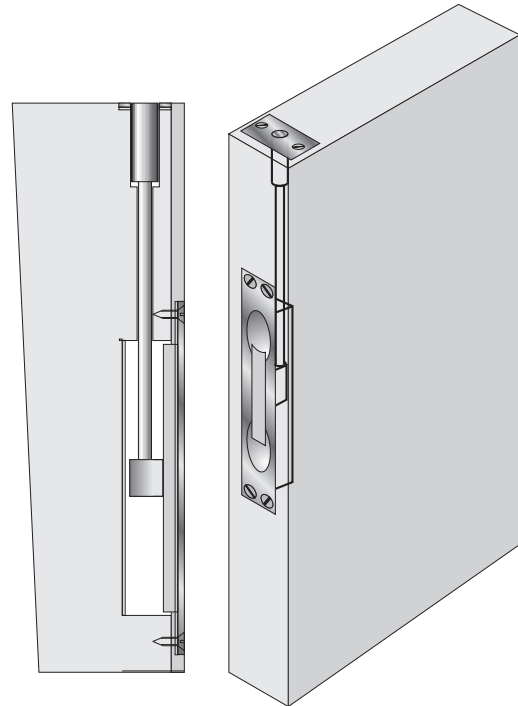

Other Hardware:

- Surface mounted hardware such as kick & buffer plates can generally be used without detriment to mechanical performance.

NOTE: *The use of PVC protection plates is recommended in preference to metal plates. Sharp edges can be created when using metal plates, (particularly aluminium) resulting from impact damage with a consequent risk to users of a building.*

- It is recommended that pull handles should be of the 'bolt-through' type used in conjunction with load spreading washers on the bolted face with pull handle fixings covered by a finger plate.

- Surface mounted Emergency Exit & Panic devices and surface mounted barrel bolts (e.g. Versabolt IR Laidlaw Ref. 34 008) can generally be used without weakening the door construction.

- Edge fixed flush bolts can weaken the door construction in a similar manner to locks and latches. Use of concealed rod type edge fixed flush bolts (e.g. John Planck Ltd. Ref. RB-001 or 001R) is recommended as a preferred alternative to edge fixed flush bolts for mechanical strength purposes.

