

Section 14

14

Fire Door Installation

Fire Door Installation:

Doorsets are not free standing products and they will not provide for any design performance until they have been competently installed into a suitable structure.

The primary purpose of any doorset is to provide a means for 'traffic' to pass from one side of a wall to the other. To achieve this objective the doorset should be easy to use. If the installed doorset is difficult to operate the users of the building may disable elements of the doorset on the basis of user convenience with consequential safety risks. e.g. by wedging fire doors in an open position.

It is vital that performance doorset are installed by competent tradesmen and It is strongly recommended that the installer is a member of a recognised quality assurance scheme, such as the 'Q' Mark Fire Door Installers scheme to ensure that best practice is used.

Installers should be familiar with the content of BS8214 : 2008 - Code of practice for fire door assemblies. Fur further guidance can be found by reference to the Architectural and Specialist Door Manufacturers (ASDMA) published Installation Guide that is reproduced by reference to *Section 15 Pages 15.5 ~ 15.8 of this manual.*

This section provides for further guidance but does not include for details with regard to any particular brand or type of fixing or for any particular method of packing doorsets at fixing positions. Most installers have there preferred methods but these should generally comply with the following advice.

Strebord[®] based doorsets are 'Q' Mark approved for installation into most structures including:

- Cast dense concrete
- Dense concrete blocks or brickwork.
- Lightweight concrete
- Lightweight aerated concrete.
- Timber stud partition.
- Steel stud partition.

NOTE 1: All structures should provide for secure fixings and in the case of Steel stud partitions, the jamb fixing studs should be generally be back filled with softwood to receive fixings.

NOTE 2: Doorsets may be fixed to some propriety steel stud partitions where the particular partition system has been successfully tested to the required performance with timber doorsets. In this event fixings must comply with the partition suppliers (manufacturers) specifications.

Installation Fixings:

Fasteners used for the installation of doorsets must be of a size and type suitable for securing into the medium into which the doorset is to be installed.

Fixings must penetrate the structure to a minimum depth of 40mm.

NOTE: Where grounds are used, the fixings must pass through the grounds to a minimum depth of 40mm into the surrounding structure.

When installing doorsets into masonry walls it is recommended that fixings should be located at least 25mm from the face of the base block work or brick work wall.

Steel wood screws are approved for use with timber stud partitions and for use with steel stud partitions that incorporate a timber infill.

When fixing to propriety metal stud partitions without timber infill the fixings must be of the size and type approved by reference to the partition manufacturers fire test / assessment data.

Installation Fixings *Fig. 14.1*

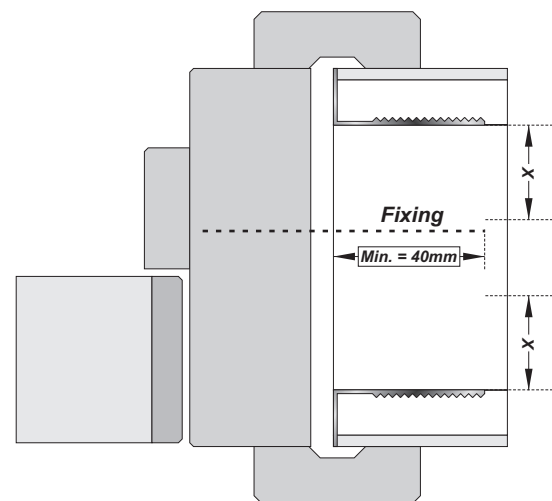

a/ Steel fixings to penetrate structure to a minimum depth of 40mm.

b/ For masonry walls it is recommended that fixings are located a minimum of 25mm (dim. x) from the face of the base block / brick structure.

c/ Fixings may be covered by use of the door stop, pellets or by the intumescent seals.

Fire Door Installation

Installation Fixings contd.:

The positioning of installation fixings in height should be planned to avoid conflicts with hardware, sealing systems and other building elements.

- **A top fixing must be located within 100mm from the underside of the frame head.**
- **A bottom fixing must be located 100mm from the bottom of the jamb.**
- **Intermediate fixings must be located at centres of not more than 600mm.**
- **The minimum number of fixings in height must be:**
 - a/ Doorset height up to 2000mm = 4No.
 - b/ Doorset height 2000 ~ 2500mm = 5No.
 - c/ Add 1No. fixing for each further 500mm increase in doorset height.
- **For storey height doorsets a top fixing must be provided within 100mm from the underside of the frame head with a further top fixing positioned 100mm from the under side of the transom rail (or bottom edge of the over panel if a flush overpanel design is used).**
- **For doorset widths in excess of 1100mm the use of an additional fixing centre width of the doorset at the head position is recommended.**
- **MDF frames are more flexible than timber frames. To reduce the risk of frame distortion during fixing it is strongly recommended that the dimension for fixing centres between intermediate fixings is reduced from 600mm to a maximum of 500mm.**

Installation Fixings contd.: *Fig. 14.2*

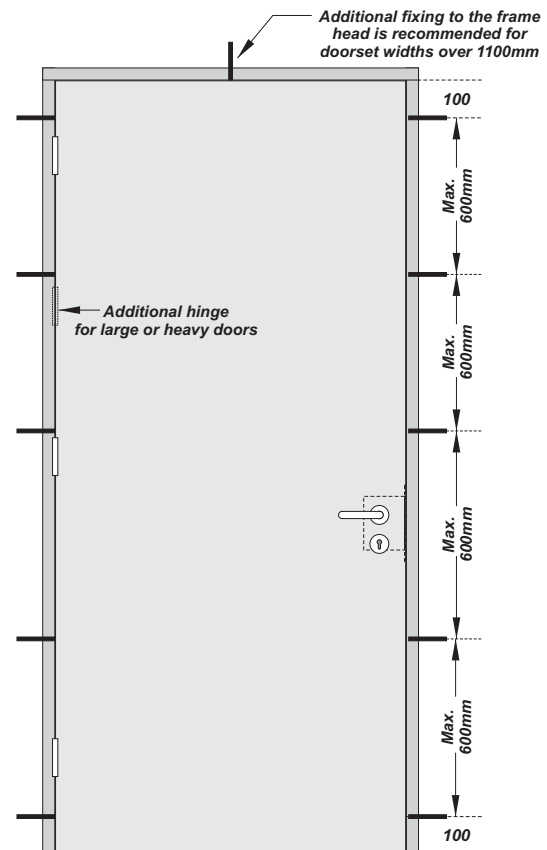

Timber frame fixing locations illustrated.

Fire Performance Walls and Partitions:

The wall and partition constructions shown in this section are for illustration purposes only.

There are numerous wall and partition constructions and Designers must ensure that the designs used for any particular project are suitable to receive fire doors to the required performance.

The wall / partition designs must also provide for the secure fixing of doorsets.

Locating Doorsets:

For 2nd. fix Fire Door installation, doorsets must be positioned centrally in the opening width with equal packing to both sides.

For single action doors it is recommended that doorsets are aligned with the wall / partition faces towards the opening face of the door. For double action doorsets doorsets should be aligned relative to a single selected face.

Doorsets should be installed plumb and square and the use of the door leaf as an installation template is recommended to reduce the need for subsequent adjustments.

Timber Grounds:

Timber grounds may be used to adjust opening dimensions to receive fire rated doorsets up to FD60 (BS476 Pt.22).

The use of timber grounds is recommended to provide for 'prepared openings' to receive doorsets. See Section 8 - Doorset Coordination.

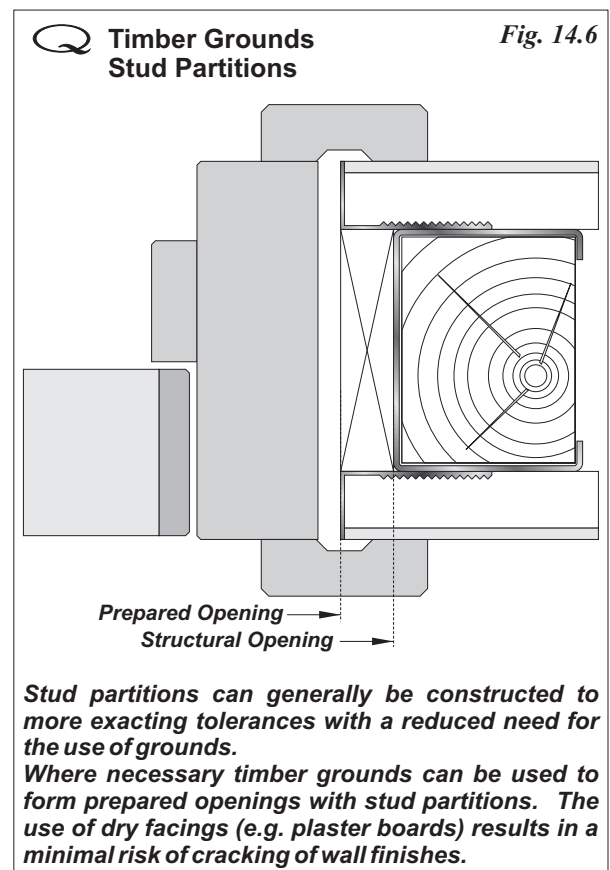
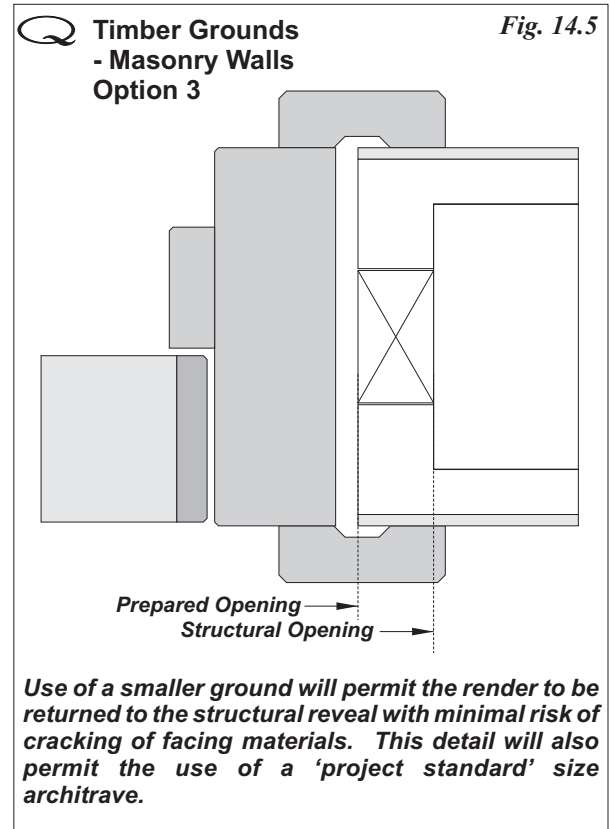
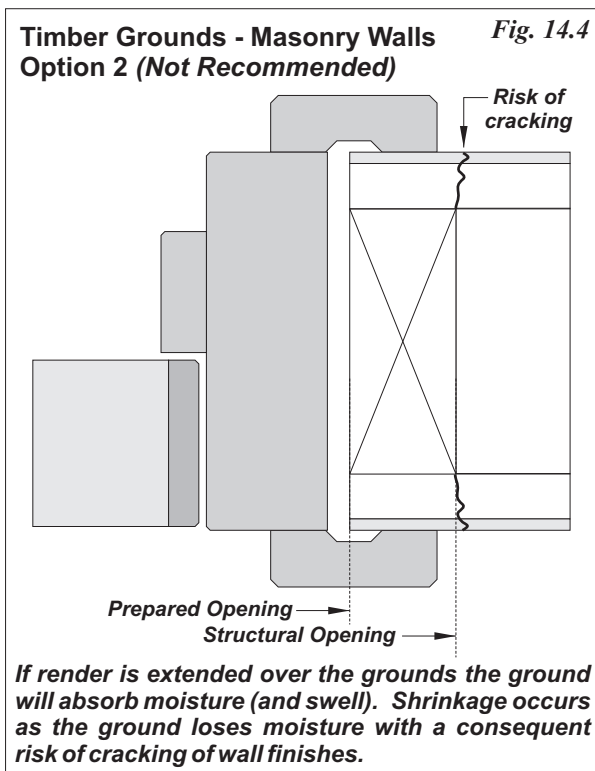
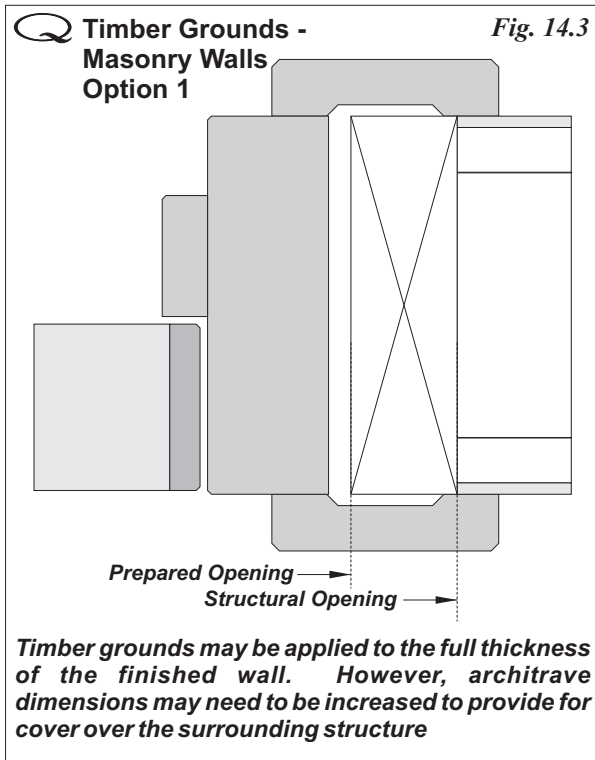

Installation Gaps contd.:

Q Installation Gaps 15~20mm *Fig. 14.10*

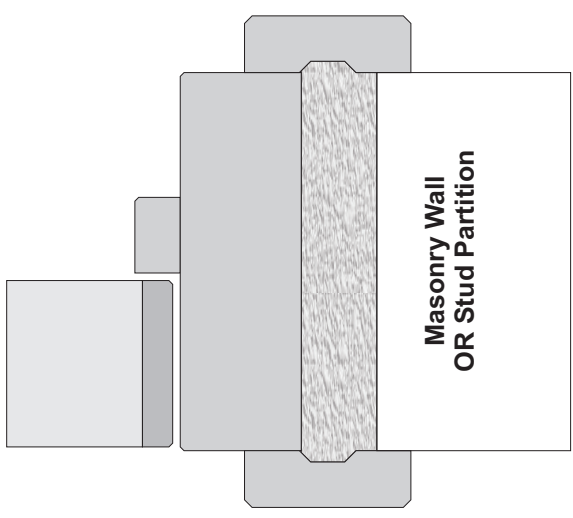

Installation gaps in excess of 20mm are not approved and the opening must be adjusted by the use of timber grounds or in other ways to create prepared openings.

For installation gaps of 15 ~ 20mm the preferred method is to adjust the opening by the use of timber grounds. However gaps between the back of the frame and the surrounding structure may be filled with a proprietary fire stopping product between fixing positions. (e.g. expanding PU foam or preformed compressible intumescent foam)

NOTE: Expanding PU foam or preformed compressible intumescent foam used for this purpose must have been satisfactorily tested for this application to the requirements of BS476 Pt.22 : 1987 or BS EN 1634-1 : 2000.

Profiled Architrave: *Fig. 14.11*

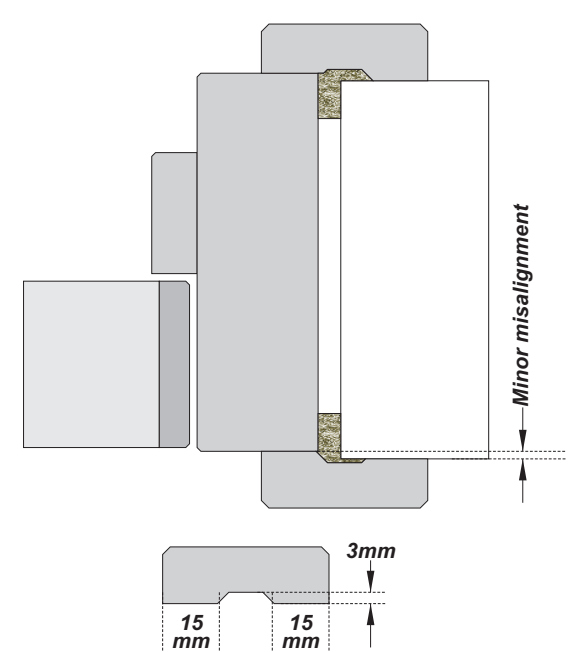

Although not specifically required for 'Q' Mark applications, the use of profiled architrave is recommended to provide for:

- a/ A working surface for the adjustment of architrave to ensure a good fit in the event of any minor misalignment between the frame and the surrounding structure.**
- b/ A pocket to house sealants required for performance doorsets. i.e. for fire rated and acoustic doorsets.**
- c/ Reduced risk of unsatisfactory movement of timber in the event of variations in moisture content resulting in changes in environmental conditions.**

Metal Frames:

Metal frames must be installed strictly in accordance with the frame manufacturers installation instructions including all intumescent packing and /or the like for use with wood or wood based door leaves.

Fire Door Installation

Adjusting Door Leaves:

The extent to which door leaves need to be adjusted will be influenced by a number of factors including:

- **Provisions made at the time of manufacture.**
- **Environmental conditions affecting moisture contents during transport and storage.**
- **Quality of installation.**

When installed, the operating gaps between the door and the frame and at the meeting stiles of pairs should comply with BS4787 Pt.1 : 1980 when measured from the opening face of the door leaf.

It is recommended that the moisture content of the door leaf is checked before attempting to adjust door leaves.

NOTE: Timber can grow or shrink across the grain, on average by 1% for each 4% variation in moisture content. Adjusting door leaves that have absorbed excessive moisture during transport, storage or during installation while wet trades are in attendance, may give rise to subsequent operating gap issues following the commissioning of the building heating and ventilation systems.

The site adjustment of door leaves may be required to suit individual location requirements. The need for adjustments will be reduced if the doorsets are installed plumb and square and where the door leaf (rather than the surrounding structure) is used as the installation template.

The application of a 'leading edge' may be required for some locations. (See *Door Growth Formula - Section 8 - Doorset Coordination*).

NOTE: Some door manufacturers offer a 'leading edge' service as a factory applied optional extra. This will usually provide for a fixed chamfer of 2° applied to the closing stiles of doors.

Strebord[®] based fire doors may be reduced on site by planing lippings. The extent of the reduction should be the minimum necessary to provide for the correct operation of the door but must not exceed 20% of the original lipping thickness.

Where intumescent seals are fitted to the door leaf, these must be removed before adjusting the door and refitted (with additional grooving) after the adjustments have been completed.

For adjustments in widths lippings must be reduced equally on both vertical edges of the door.

For reductions in height, adjustments may be limited to the bottom edge only unless otherwise required by reference to specific project specifications.

Doorsets with Acoustic / Smoke Seals:

Additional care is required where doorsets are fitted with smoke or acoustic seals.

Potential problems Doorsets with Acoustic / Smoke Seals:

Fig. 14.12

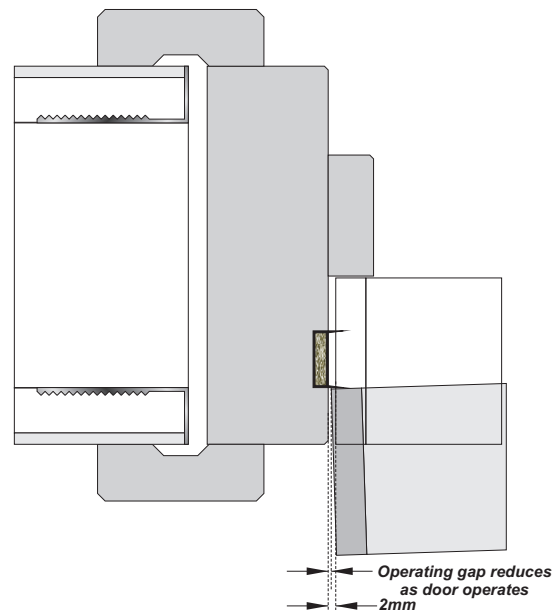

If door leaves are fitted with square edges and corners when used with doorsets fitted with combined intumescent / smoke seals the following difficulties may be experienced:

a/ The operating gap between door and frame at the closing stile will reduce as the door closes (and opens).

b/ There will be increased resistance to the operation of the door.

c/ Square corners may bite into seal blade with consequent risk that blade may tear from carrier.

Doorsets with Acoustic / Smoke Seals contd.:

**Recommendations
Doorsets with
Acoustic / Smoke Seals:** *Fig. 14.13*

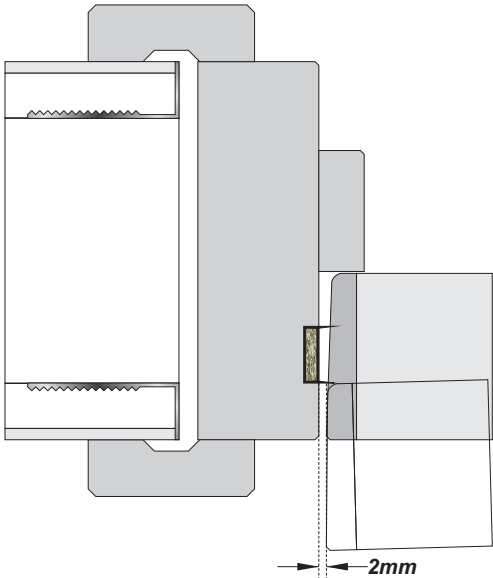

The following actions are recommended to overcome the potential problems identified by reference to Fig. 14.12:

- a/ Over recess the intumescent seal by 0.5mm to relieve stress at the blade / carrier junction.
- b/ Apply a leading edge (particularly to the closing stile) to maintain a constant operating gap as the door closes (opens).
- c/ Apply a pencil round to the closing edges of the door leaf to act as a lead for the compression of smoke / acoustic seals.

NOTE: The use of pencil rounds is recommended for all edges of the doors. Apart from acting as a lead for the compression of seals, this feature will also provide for:

- i/ Improved application of paint and lacquer finishes.
- ii/ Reduced risk of injury to users in the event of impact with door edges.

Operating gaps & Seal gaps:

The gap between the door and the frame must be suitable to provide for effective smoke / acoustic sealing at the seal position, particularly in respect of frame reveal fitted seals.

Generally separate seals that fit near to the frame doorstop will provide for reduced influence on the operation of the door.

It is recommended that 'operating gaps' and 'seal gaps' are considered as separate issues and that seal designs should provide for a means of adjustment to suit the particular application.

Operating gaps & Seal gaps: *Fig. 14.14*

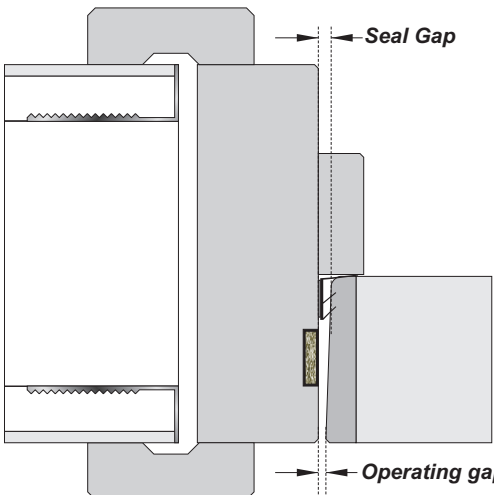

The use of separate intumescent and smoke / acoustic seals is recommended by Falcon Panel Products Ltd. for the following reasons:

- a/ Smoke / Acoustic seals can generally be located in positions that have a minimal influence on the operation of the door.
- b/ 'Batwing' and Norsound 710 type seals with adhesive backing can be adjusted by the use of backing tape to provide for the optimum balance between sealing efficiency and influence on operating forces.
- c/ The smoke / acoustic seals are located in positions with a low risk of damage in use but may be easily replaced if necessary without disturbing intumescent seals.

Fire Door Installation

'Q' Mark Approval:

To maintain 'Q' Mark approval, an installed fire rated doorset must satisfy the following requirements:

a/ Lippings must not be reduced by more than 20% of the original sectional thickness.

b/ Leading edges may be applied but the chamfer must not exceed 2.5°.

c/ Edge profiling (e.g. pencil rounds) to be Max. 8mm radius.

d/ The maximum permissible gap at the intumescent seal position(s) within door thickness, must not exceed 4mm.

e/ The door leaf must not project more than 1mm from the face of the frame lining (*before the application of architrave*).

f/ The packing of installation gaps must comply with approved details illustrated in *Section 14 - Fire Door Installation*.

g/ Frame materials and sectional details must comply with the requirements of *Section 7 - Frames*.

h/ Fire doors must be lipped to comply with approved details described by reference to *Section 3 - Lippings & Facings*. See also: *Section 13 for Panelled door designs*.

j/ Door facings must comply with details described by reference to *Section 3 - Lippings & Facings*. See also: *Section 13 for Panelled door designs*.

k/ Intumescent seals must be of the size and type suitable for the particular doorset design by reference to *Section 2 - Fire Door Applications*. (*Section 13 for Panelled door designs*).

m/ Intumescent seals must be located as described by reference to *Section 4 - Intumescent Sealing*. (*Section 13 for Panelled door designs*).

n/ Glazing in fire doors must comply with details described by reference to *Section 6 - Glazing*, including glass type, glazed area and intumescent glazing / beading system. See also: *Section 13 for Panelled door designs*.

p/ Hardware used with fire rated doorsets must comply with details provided by reference to *Section 9 - Hardware*, including all intumescent gaskets, sealing and the like. See also: *Section 13 for Panelled door designs*.

It would be an impossible task to attempt to anticipate every possible doorset design or design variant.

The content of this manual will cover most application requirements.

Where particular project designs require applications that fall outside of the scope of this manual it may be possible to provide for a 'Project Assessment' based upon specific details.

Requests for 'Project Assessments' under the 'Q' Mark scheme may be forwarded by any 'Q' Mark member to

Chiltern International Fire
 Chiltern House,
 Stocking Lane,
 Hughenden Valley,
 High Wycombe,
 Buckinghamshire HP14 4ND

Tel: (0)1494 569800
 Fax: (0)1494 564895
www.chilternfire.co.uk