

General:

Doors are glazed primarily for the safety of users of a building. However, glazing is often used as a means for expressing aesthetic considerations.

Strebord® provides for a stable core construction that offers wide scope for glazing.

It would be an almost impossible task for one manufacturer or supplier to test every conceivable variation in glass type and beading system. This section sets out some options but other options may be considered subject to supporting fire test / assessment documentation.

NOTE 1: Further information with regard to glass and glazing systems for fire rated doorsets can be obtained by reference to 'A Guide to Best Practice in the Specification and Use of Fire Resistant Glazed Systems' (2008) published by the GGF (Glass & Glazing Federation).

NOTE 2: Use of components from sources that are subject to the 'Q' Mark product assurance scheme are recommended.

WARNING: It is essential that the fire test / assessment data for the glazing system relates to use in wood doors. Glass and beading systems proven for use in metal doors or glazed screens may not be suitable for use in wood doors.

Glass Types:

Generally glass will fall into one of two categories:

Uninsulated: Glass in this category would include 6mm Georgian Wired e.g. Pilkington's Pyroshield; Borosilicate glass e.g. Shott Glass Pyran; Ceramic glass e.g. Southern Ceramics Firelite. These glass types have the potential to provide for integrity performances covered by this manual when used with appropriate intumescent beading systems but they do not stop the transfer of heat from the fire side to the non fire side of the door.

To reduce the risk of ignition on the non fire side of the door due to heat transmission, the bead profiles should be splayed unless there is fire test / assessment data to support the use of non splayed beads.

Insulated: Glass in this category is generally made up of multiple layers of float glass interleaved with clear hydrated sodium silicate intumescent material.

Glass types in this category include: Pyrobel (AGC Flat Glass Europe) and Pyrostop (Pilkington Glass Ltd.)

NOTE: These glass types should be handled and fitted with care and in strict conformity with the glass manufacturers recommendations. Exposure of the edges of the glass can cause a breakdown in the intumescent interlayers visible as discolouration on the face of the glass.

Wood doors, including doors made using Strebord® cores provide for insulating properties that generally equal the integrity performance when used as flush doors. Unless used with insulating glass types, the insulation performance is generally reduced when doors are glazed.

BS 476 Pt.22 provides for tests of fully insulated or partially insulated specimens.

For fully insulated performances an insulating glass must be used to prevent the temperature on the non fire face from rising above (average) 140°C above ambient temperature or 180°C above ambient temperature at any point.

For partially insulated specimens the 140°C average may be exceeded to an unspecified level over an area not exceeding 20% of the area of the test specimen.

If full insulation is required, the insulation performance of the glass should be at least equal to the insulation performance of the door construction. However, for most applications, an insulation performance equal to 50% of the integrity performance is satisfactory.

Where the insulation performance of the glass is 50% (or more) than the integrity performance of the door, the risk of ignition on the non fire face of the door due to heat transmission is considerably reduced providing for greater scope in the design of the bead profile.

BS 6206 (BS EN 12600) Safety Class:

In addition to fire performances, consideration must also be given to the BS 6206 Safety Performance. The Safety Class will vary according to the location of the glass aperture in the door leaf (assembly). (See Building Regulations - [England & Wales] - Approved Document 'N'). In addition, certain projects (e.g. Schools) may require special Safety Class requirements.

NOTE: Whereas Building Regulations (England & Wales) Approved Document 'N' make reference to BS 6206 safety classes impact performances determined by reference to BS EN 12600 may be substituted for the BS 6206 Classes by reference to the following:

BS6206	=	BS EN 12600
Class 'A'	=	Class 1
Class 'B'	=	Class 2
Class 'C'	=	Class 3

General Notes:

NOTE 1: Building Regulations - (England & Wales) - Approved Document 'N' requires that a safety glass (BS 6206 Class C for pane widths up to 900mm - Class B for pane widths over 900mm) is used for the glazing of doors up to a height of 1500mm above floor level.

NOTE 2: Building Regulations - (England & Wales) - Approved Document 'B' (Table A4 note 5) requires that fire-resisting glass should be marked with the manufacturer and product name.

NOTE 3: BS 6262-4:2005 (clauses 7.1 & 7.2) requires that safety glass should be indelibly marked to be visible after beading.

Glass & Glazing

Beading Systems for Fire Doors:

To perform correctly, the glass must be retained in a beading system that incorporates intumescent sealing.

FD30:

For fire performances up to FD30, beading using Min. 640kg/M3 @ 15% moisture content hardwood is recommended. Bolection bead (splayed beads with nibs that extend over the face of the door) may be used with either non insulating or insulating glass types. Flush beads (square section glazing beads that do not project beyond the face of the door) are generally limited for use with insulating and partially insulated glass types. (See details)

FD60:

For fire performances up to FD60, beading using Min. 640kg/M3 @ 15% moisture content hardwood is recommended. Bolection bead (splayed beads with nibs that extend over the face of the door) may be used with either non insulating or insulating glass types. Flush beads (square section glazing beads that do not project beyond the face of the door) are generally limited for use with insulating glass types. (See details)

Propriety Intumescent Glazing Systems:

Various Intumescent Seal manufacturers offer propriety systems for glazing fire doors.

WARNING: It is important to ensure that the system selected for beading fire doors has been tested or assessed to the required level of performance in a wood door. Test / assessment data relating to the beading of metal doors or glazed screens should not be applied to wood doors.

NOTE : Use of beading systems from sources that are subject to the 'Q' Mark product assurance scheme is recommended.

Manufacturers / suppliers offering Intumescent Glazing Systems for use with fire doors include:

Norseal Ltd.
Lorient Polyproducts Ltd.
Mann McGowan Ltd.
Intumescent Seals Ltd.
Sealmaster Ltd.
Pyroplex Ltd.

These systems should be used strictly in accordance with the seal manufacturers fitting instructions.

Dimensions and Margins:

When glazing doors manufactured from Strebord® cores, the total clear glass area of the glazing should not exceed the area permitted by reference to the relevant Strebord® fire test / assessment documents.

Further, the glass apertures should be located to ensure an adequate margin between the nearest edge of the door and the sight line of the aperture in the door to receive glazing and between the sight line of adjacent glazing apertures.

NOTE: This data is constantly changing as a consequence of an on going fire test programmes.

Bead Fixings:

FD30: Beads may be fixed using 50mm long x 2mm diameter steel pins or 40mm long No.8 screws, inserted at 30~35° to the vertical at no more than 50mm from each corner and at 150mm max. centres.

FD60: Beads may be fixed using 60mm long x 2mm diameter steel pins or 60mm long No.8 screws, inserted at 35~40° to the vertical at no more than 50mm from each corner and at 150mm max. centres.

NOTE: Where screw fixed beads are required, the screws should be to one face only, steel cups & screws should be used for this purpose. (high melt temperature brass cups and screws may be used where the melt temperature of the fixings exceeds 800°C).

Security:

Some specifications require a security performance in addition to a fire performance. The bead may be designed to restrict removal from one face by use of a combined lining and bead. The combined lining / bead can be glue fixed (with reinforcing centre fixed screws if required) such that there are no visible fixings on the secure face. A removable pinned or screw fixed bead can then be applied to the non secure face.

NOTE: Laminated glass providing for security performances use polymer interlayers and not intumescent interlayers. These glasses are not suitable for use with fire rated doorsets.

Technical Support:

Where design requirements describe glazing that falls outside of the scope of the assessed applications envelopes described in this manual for any particular performance, details of the requirement should be forwarded for further comment to:

Falcon Panel Products Ltd.,

Clock House,
Station Approach,
Shepperton,
Middlesex TW178AN

Tel: 01932 256580

Fax: 01932 230268

Recommended Aperture preparation and Beading for Laminate (and brittle material) faced Doors:

Fig. 6.1

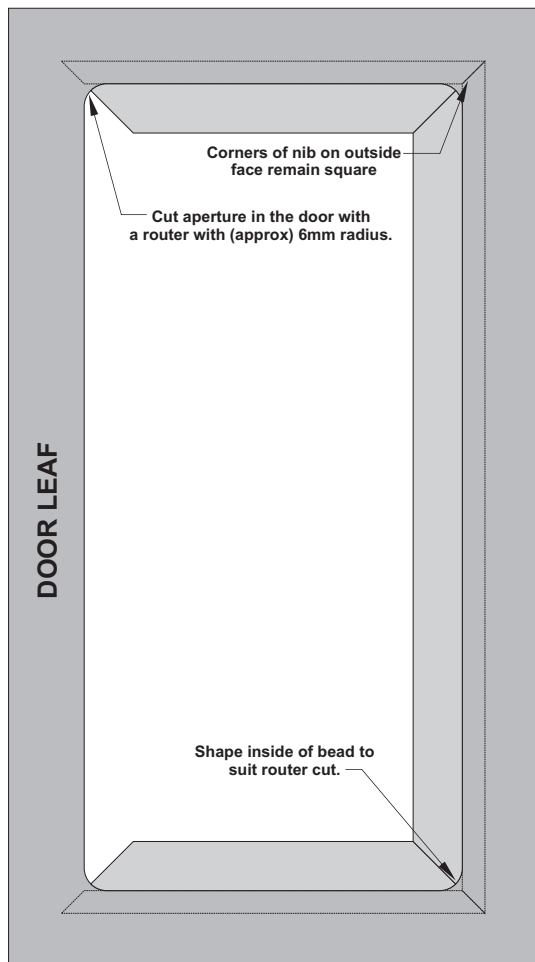

Strebord® is essentially a wood based product. Whereas this material demonstrates a high degree of stability, some movement can be expected where the core is subjected to significant changes in environmental conditions and in particular, where such changes take place over a short period of time.

When used with plastic laminates (or facing materials with similar properties), differential movement between the facing material and the core can lead to stresses that may become evident by cracking of the facing material with the cracks generally originating from apertures in the face of the door.

The risk of this occurrence can be significantly reduced where the corners of the apertures are left rounded. This can be achieved in two ways:

1/ When used with a bolection bead, round the back of the beads at the corners to match the router cut in the aperture. *(The appearance of the cover nib on the face of the door remains square).*

2/ Subject to sufficient bead nib cover, line the aperture with a suitable 3mm material (say plywood) to create square corners to receive the beading.

NOTE: *When used with flush beads, it is recommended that the aperture is lined with hardwood with the corners of the lining shaped to match the routed corners in the door leaf.*

Glass & Glazing
Fire Doors Dimensions
Strebord⁴⁴® FD30 Glazing Rules:

- The maximum recommended area for glazing is 2.66M² (subject to maintenance of minimum margin requirements).
- The recommended minimum margins for locating apertures to be not less than 100mm from any edge of the door.
- Where multiple apertures are used, the separation between the sight line of each glazed aperture must not be less than 80mm.
- Multiple apertures are acceptable provide the total glazed area does not exceed the maximum approved area for the particular application. Aperture shape is not restricted providing that glazing systems and beading are compatible with that shape.

WARNING: The maximum permitted aperture dimension may be reduced according to the selected glass type and the method of beading. See 'Q' Mark approved Glass Types and Beading systems for FD30 applications.

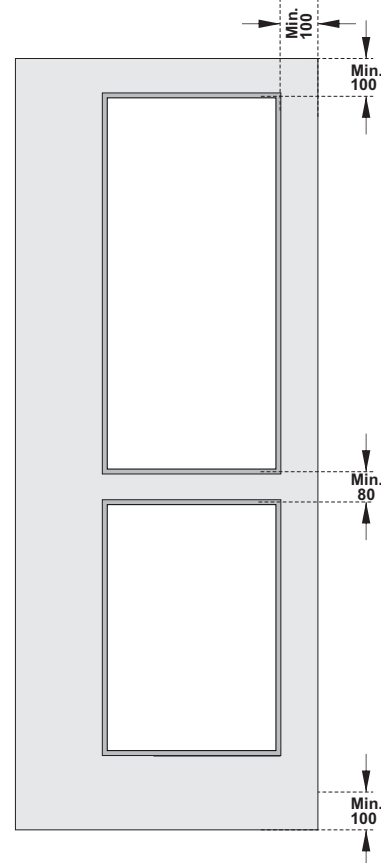
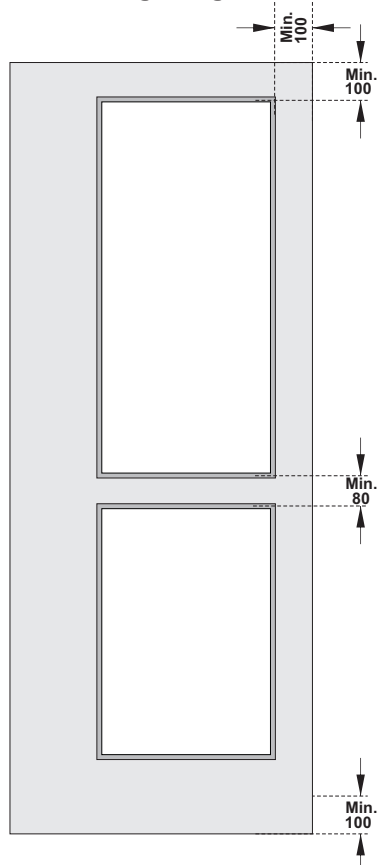
Q FD30 - 'Q' Mark approved Glazing margins. *Fig. 6.2*

Q FD60 - 'Q' Mark approved Glazing margins. *Fig. 6.3*

Strebord⁵⁴® FD60 Glazing Rules:

- The maximum recommended area for glazing is 0.72M² (subject to maintenance of minimum margin requirements).
- The recommended minimum margins for locating apertures to be not less than 100mm from any edge of the door.
- Where multiple apertures are used, the separation between the sight line of each glazed aperture must not be less than 80mm.
- Multiple apertures are acceptable provide the total glazed area does not exceed the maximum approved area for the particular application. Aperture shape is not restricted providing that glazing systems and beading are compatible with that shape.

WARNING: The maximum permitted aperture dimension may be reduced according to the selected glass type and the method of beading. See 'Q' Mark approved Glass Types and Beading systems for FD60 applications.

Glass & Glazing
Glass Types for Fire Doors

FD30 Glass Type		Max. Approved Glazed Area	Nom. Thickness	Insulation	BS6206 Safety Class
Q	PYROSHIELD Safety (Wired) - Pilkington Glass Ltd. Clear	2.66M ²	6mm	Nil.	C
Q	PYROSHIELD Safety (Wired) - Pilkington Glass Ltd. Textured	2.66M ²	7mm	Nil.	C
Q	PYROSWISS - Vetrotech Saint Gobain See NOTE 1	0.8M ²	6mm	Nil.	A
Q	PYRAN S - Schott Glass Ltd.	2.66M ²	6.5mm	Nil.	A
Q	PYROGUARD (wired) - CGI Ltd.	0.87M ²	7.2mm	Nil.	B
Q	PYROGUARD (clear) - CGI Ltd.	0.87M ²	7.2mm	Nil.	B
Q	PYROBELITE - AGC Flat Glass Europe.	2.66M ²	7mm	11min. approx.	C
Q	PYRODUR Plus - Pilkington Glass Ltd.	2.66M ²	7mm	15min. approx.	B
Q	PYRODUR - Pilkington Glass Ltd.	2.66M ²	10mm	16min. approx.	B
Q	PYROGUARD (clear) - CGI Ltd.	0.52M ²	11mm	Nil.	B
Q	PYROBELITE - AGC Flat Glass Europe.	2.66M ²	12mm	30min. approx.	B
Q	PYROSTOP - Pilkington Glass Ltd.	2.66M ²	15mm	30min.	B
Q	PYROBEL - AGC Flat Glass Europe.	2.66M ²	16mm	30min.	B

FD30 'Q' Mark Approved Glass Types:

This table lists some of the more popular glass types that may be used with Strebord[®] FD30 fire doors.

Other glass types may be used subject to further fire test / assessment data to be provided by the glass manufacturer (supplier) and, where the glass type is approved for use in timber doors.

It is essential to use the correct beading system to suit the fire performance and the glass type.

NOTE 1: The glazing / beading system for use with this glass type is limited to 'Firestrip 30' detail - See page:

FD60 'Q' Mark Approved Glass Types:

This table lists some of the more popular glass types that may be used with Strebord[®] FD60 fire doors.

Other glass types may be used subject to further fire test / assessment data to be provided by the glass manufacturer (supplier) and, where the glass type is approved for use in timber doors.

It is essential to use the correct beading system to suit the fire performance and the glass type.

FD60 Glass Type		Max. Approved Glazed Area	Nom. Thickness	Insulation	BS6206 Safety Class
Q	PYROSHIELD Safety (Wired) - Pilkington Glass Ltd. Clear	0.72M ²	6mm	Nil.	C
Q	PYROSHIELD Safety (Wired) - Pilkington Glass Ltd. Textured	0.72M ²	7mm	Nil.	C
Q	PYRAN S - Schott Glass Ltd.	0.72M ²	6.5mm	Nil.	A
Q	PYRODUR - Pilkington Glass Ltd.	0.72M ²	10mm	16min. approx.	B
Q	PYROGUARD (clear) - CGI Ltd.	0.52M ²	11mm	Nil.	B
Q	PYROBELITE - AGC Flat Glass Europe.	0.72M ²	12mm	30min. approx.	B
Q	PYRODUR - Pilkington Glass Ltd.	0.72M ²	13mm	30min. approx.	B
Q	SWISSFLAM Lite - Vetrotech Saint Gobain Ltd..	0.72M ²	14mm	15min. approx.	A
Q	PYROSTOP - Pilkington Glass Ltd.	0.72M ²	15mm	30min.	B
Q	PYROBEL - AGC Flat Glass Europe.	0.72M ²	16mm	30min.	B

NOTE: Information relating to glass thickness, insulation performance and BS6206 (BS EN 12600) Safety Class is for guidance only, reference should be made to Glass manufacturer's / supplier's technical data sheets for further information.



Strebord®

Door Core

Glass & Glazing FD30

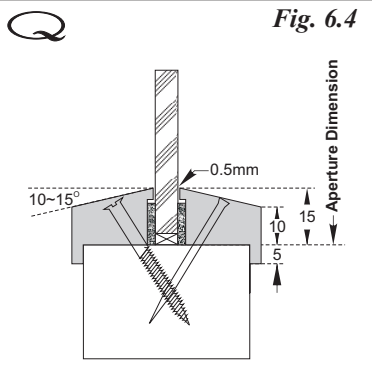

Intumescent Seals Ltd. - 'Therm-a-Strip'
Sealmaster Ltd. - 'Fireglaze 30'

- Hardwood glazing bead to be splayed 10~15°.
- Bead to be fixed using 40mm long x 2mm dia. steel pins OR 40mm long No.8 screws inserted at 30~35° to the vertical bead at no more than 50mm from each corner and at 150mm maximum centres.

Maximum approved glazed area - Therm-A-Strip = 1.9M²
Maximum approved glazed area - Fireglaze 30 = 2.66M²

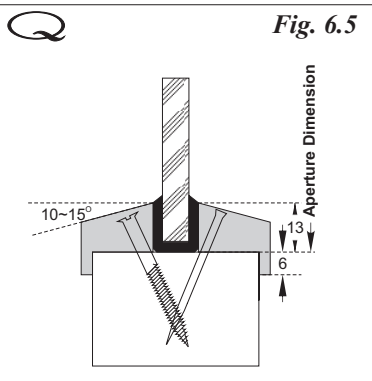

Lorient Polyproducts Ltd. - 'System 36' Glazing Channel

- Hardwood glazing bead to be splayed 10~15°.
- Bead to be fixed using 40mm long x 2mm dia. steel pins OR 40mm long No.8 screws inserted at 30~35° to the vertical bead at no more than 50mm from each corner and at 150mm maximum centres.

NOTE: Suitable for use with circular apertures

Maximum approved glazed area - System 36 = 1.33M²

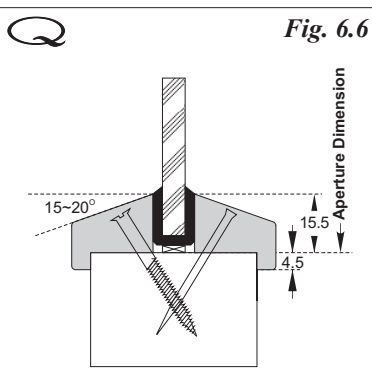

PyroPlex Ltd. - 8193 Glazing Channel

- Hardwood glazing bead to be splayed 15~20°.
- Bead to be fixed using 40mm long x 2mm dia. steel pins OR 40mm long No.8 screws inserted at 30~35° to the vertical bead at no more than 50mm from each corner and at 150mm maximum centres.

NOTE: Suitable for use with circular apertures

Maximum approved glazed area - PyroPlex 8193 = 1.33M²

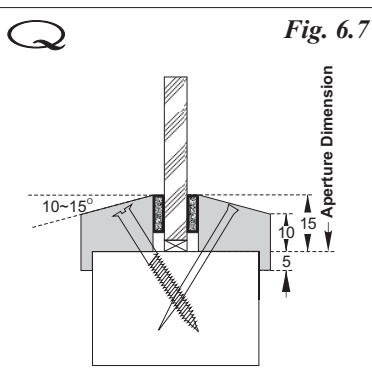

Mann McGowan Ltd. - Pyroglaze 30

- Hardwood glazing bead to be splayed 10~15°.
- Bead to be fixed using 40mm long x 2mm dia. steel pins OR 40mm long No.8 screws inserted at 30~35° to the vertical bead at no more than 50mm from each corner and at 150mm maximum centres.

Maximum approved glazed area - Pyroglaze 30 = 1.33M²

Hodgsons Sealants Ltd. - Firestrip 30

- Hardwood glazing bead to be splayed 10~15°.
- Bead to be fixed using 40mm long x 2mm dia. steel pins OR 40mm long No.8 screws inserted at 30~35° to the vertical bead at no more than 50mm from each corner and at 150mm maximum centres.

Maximum approved glazed area - Firestrip 30 = 1.9M²

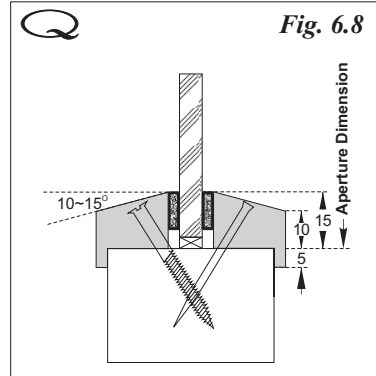

Lorient Polyproducts Ltd. - 'System FF1'

- Hardwood glazing bead to be splayed 10~15°.
- Bead to be fixed using 40mm long x 2mm dia. steel pins OR 40mm long No.8 screws inserted at 30~35° to the vertical bead at no more than 50mm from each corner and at 150mm maximum centres.

Maximum approved glazed area - Lorient FF1 = 1.33M²

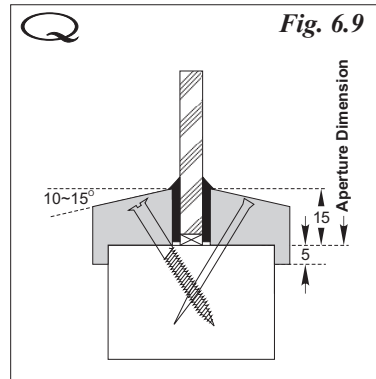

**PyroPlex Ltd. - System 30049
PyroPlex Ltd. - 30054 Glazing Gasket.**

- Hardwood glazing bead to be splayed 15~20°.
- Bead to be fixed using 40mm long x 2mm dia. steel pins OR 40mm long No.8 screws inserted at 30~35° to the vertical bead at no more than 50mm from each corner and at 150mm maximum centres.

**Maximum approved glazed area - PyroPlex 30049 = 1.33M²
Maximum approved glazed area - PyroPlex 30054 = 0.72M²**

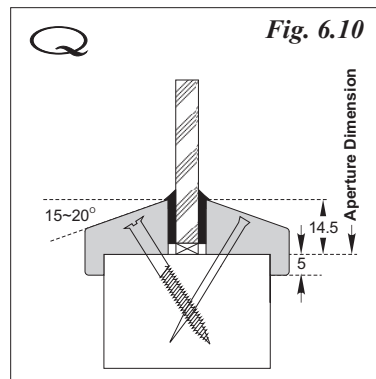

Splayed Flush Bead:

A splayed flush bead may be used with approved glazing systems subject to the following:

- The aperture in the door should be lined using min. 6mm thickness hardwood of min. 640kg/M³ density (@ 15% moisture content).
- The profile of the bead shall generally be the same as that approved for the corresponding cloak bead detail. It is important to maintain splay angle shown for approved glazing systems when used with non insulating glass.
- A small rebate (not exceeding 2x2mm) may be used to the bead or the lining accommodate door thickness tolerances.

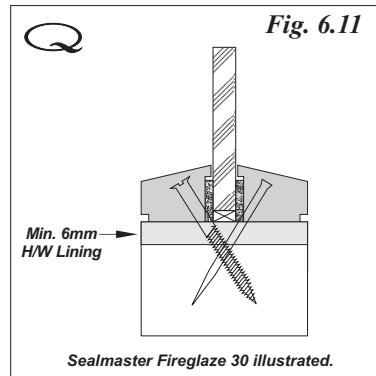

Strebord[®]

Door Core

Glass & Glazing FD30

Glazing with Insulating & Partially insulating glass types:

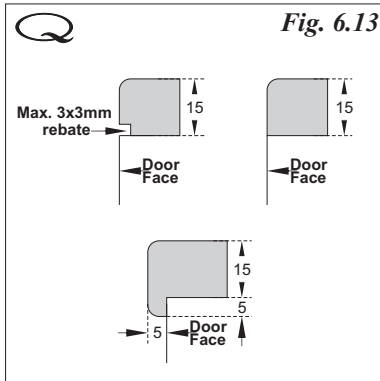

Flush & Square Beads:

The use of flush and square beads (in addition to splayed beads) is approved for use with insulating and partially insulating glass types only. See page 6.5 for 'Q' Mark approved glass types.

Maximum aperture dimensions remain as described for the particular glass type and glazing system. See pages 6.5 ~ 6.7 for 'Q' Mark approved maximum aperture dimensions for FD30 applications.

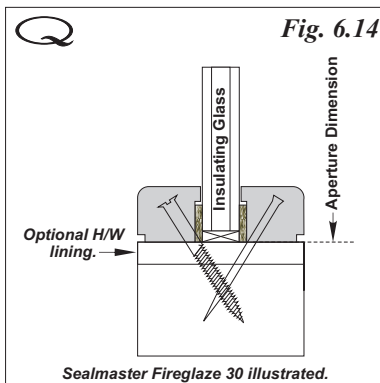

Typical Flush bead application using Insulating glass types.

- All FD30 glazing systems identified in this section may be used with glass types that provide for an insulating or partially insulating performance as identified by reference to page 6.5.
- When used with glazing channels such as Lorient System 36, care should be taken to ensure that the channel dimensions are suitable for the glass thickness. It may also be necessary to amend the bead height to suit the particular glazing system.
- Whereas it is not essential for fire performance reasons, it is recommended that apertures are lined with hardwood, particularly if the doors are to be used in a high humidity environment or are likely to be subjected to wet cleaning.
- Rebated linings incorporating flush beads may be used with insulating glass types to provide for improved security.

FD30

Multi Aperture Glazing 1.

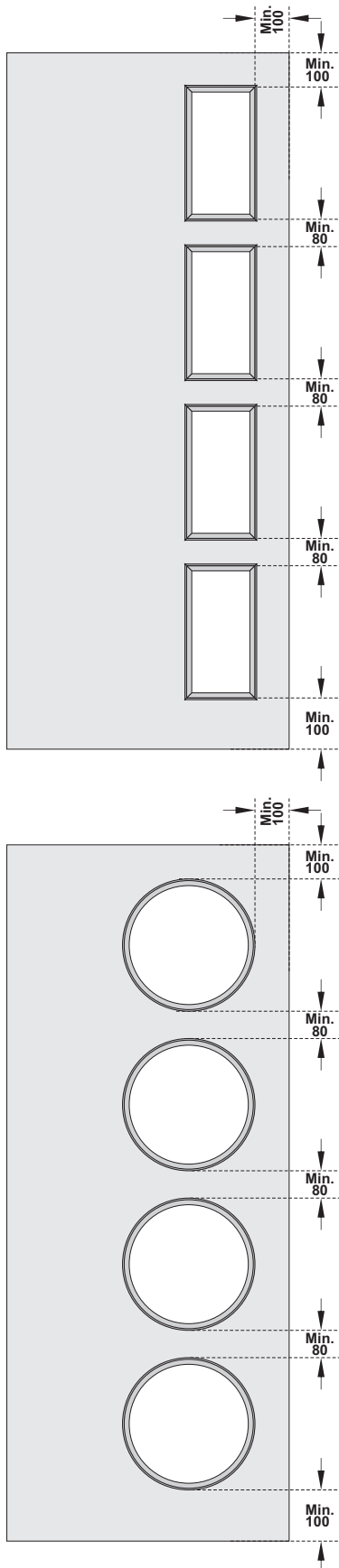
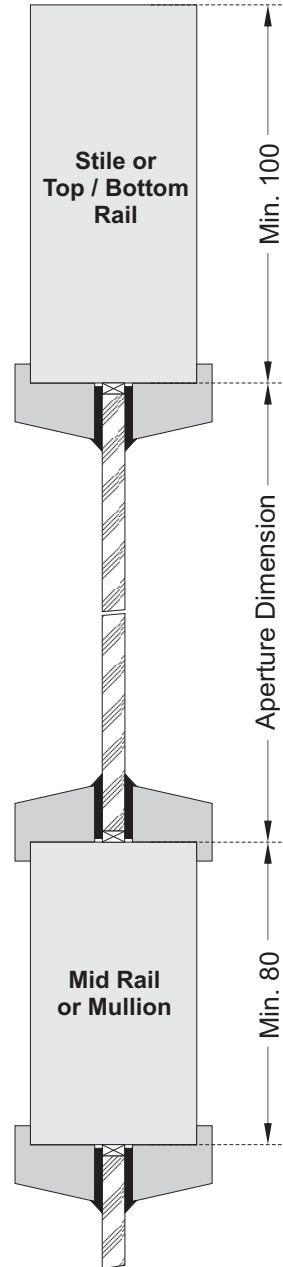

Fig. 6.15

Multi Aperture Glazing 1.

Fig. 6.16



- Subject to limitations with respect of glazed areas and use of suitable glazing systems, there are no limits with regard to the quantity or shape of glazed apertures.
- The minimum dimension from any edge of the door to the nearest sight line of the aperture should not be less than 100mm.
- The dimension between adjacent apertures should not be less than 80mm.

Fig. 6.17

Q **Multi Aperture Glazing 2.**

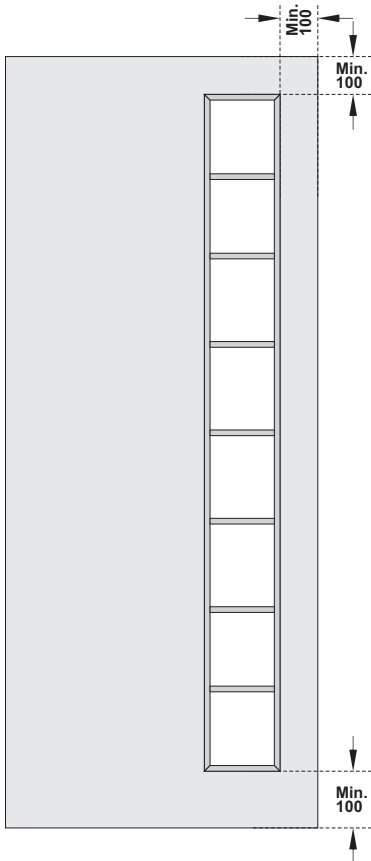

The appearance of multi aperture glazing can be created by the use of a single sheet of glass used with false beads that are bonded to the glass with an intumescent mastic / silicon, or an 0.5~2mm thick self adhesive intumescent tape / strip.

This detail is approved for use with insulating or partially insulating glass types only.

Mechanical fixings (screws / pins) should not be used for fixing the false beads.

Q **Multi Aperture Glazing 2.**

Fig. 6.18

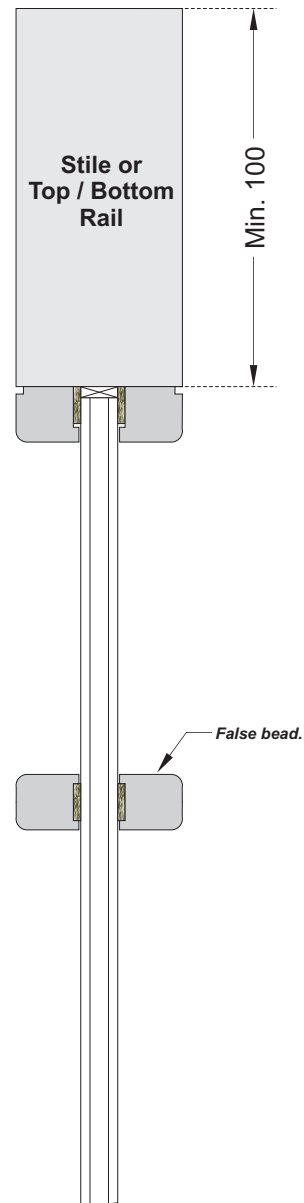

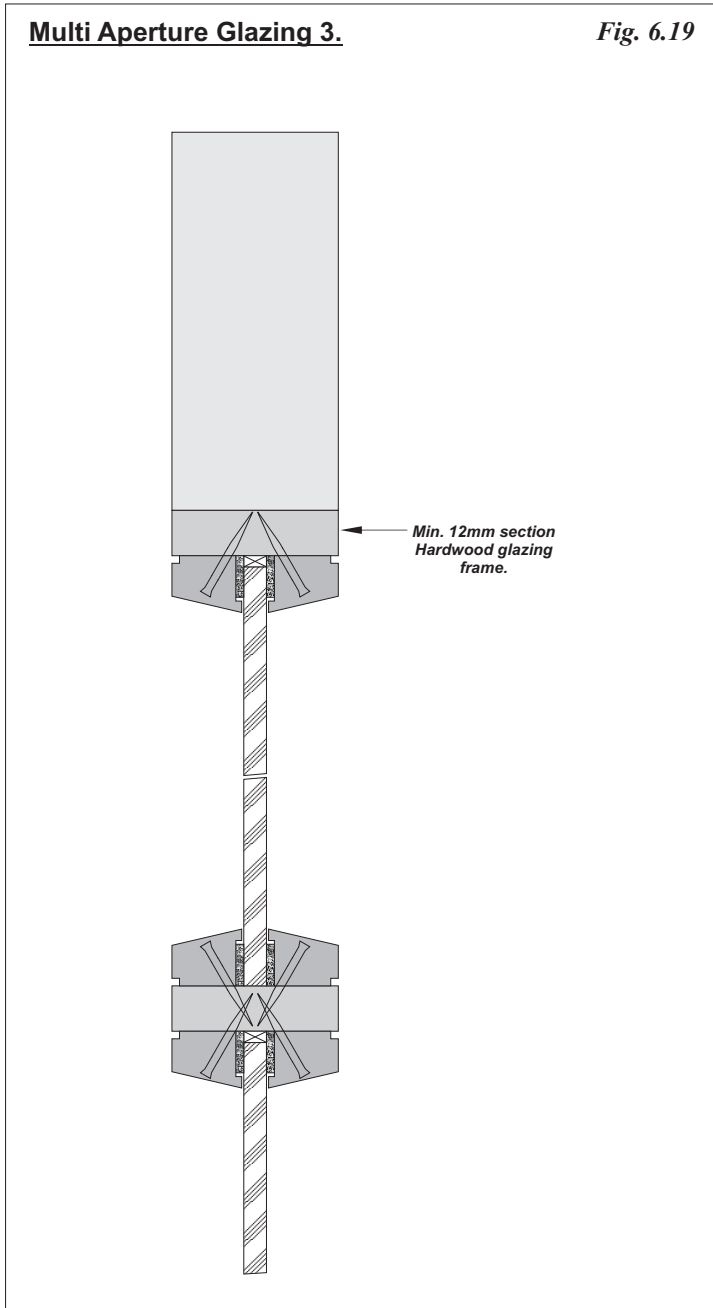

Multi Aperture Glazing 3. *Fig. 6.20*

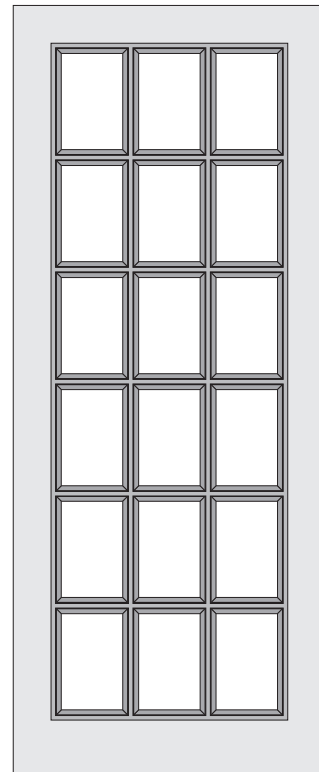

Glazing is often used in doors to provide for a means for achieving aesthetic objectives.

Strebord[®] provides for a stable door core product for this purpose.

Hardwood glazing frames can be created to suit almost unlimited pattern designs with beading fixed to the glazing frame.

NOTE: This detail is not approved for 'Q' Mark fire door applications.

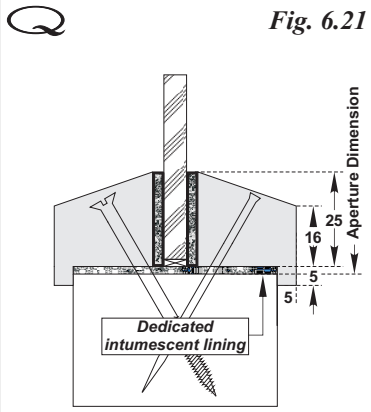

Intumescent Seals Ltd. - Therm-A-Glaze 60
Sealmaster Ltd. - Fireglaze Mastic
Mann McGowan Ltd. - Pyroglaze 60

- These systems must be used with its dedicated intumescent lining to the aperture.
- Bead to be fixed using 60mm long x 2mm dia. steel pins OR 60mm long No.8 screws inserted at 35~40° to the vertical at no more than 50mm from each corner and at 150mm maximum centres.

Maximum approved glazed area - Therm-A-Glaze 60 = 0.72M²
Maximum approved glazed area - Fireglaze Mastic = 0.72M²
Maximum approved glazed area - Pyroglaze 60 = 0.72M²

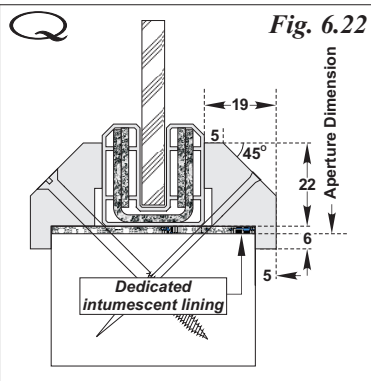

Lorient Polyproducts Ltd. - 'System 90 PLUS'

- This system must be used with its dedicated intumescent lining to the aperture.
- Bead to be fixed using 60mm long x 2mm dia. steel pins OR 60mm long No.8 screws inserted at 45° to the vertical bead at no more than 50mm from each corner and at 150mm maximum centres.

Maximum approved glazed area - System 90 PLUS = 0.72M²

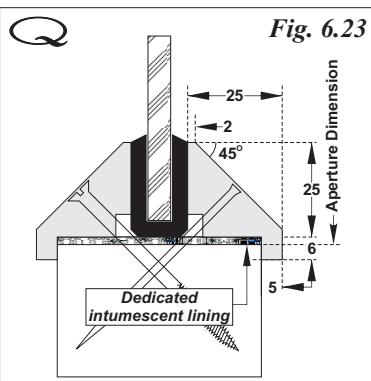

Lorient Polyproducts Ltd. - 'System 63' Flexible Gasket

- This system must be used with its dedicated intumescent lining to the aperture.
- Bead to be fixed using 60mm long x 2mm dia. steel pins OR 60mm long No.8 screws inserted at 45° to the vertical bead at no more than 50mm from each corner and at 150mm maximum centres.

Maximum approved glazed area - System 63 = 0.72M²

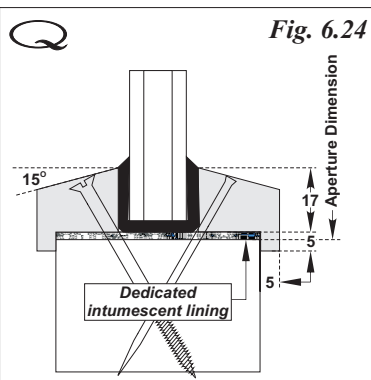

Lorient Polyproducts Ltd. - 'System 36/15' Flexible Gasket

- This system must be used with its dedicated intumescent lining to the aperture.
- Bead to be fixed using 60mm long x 2mm dia. steel pins OR 60mm long No.8 screws inserted at 35~40° to the vertical bead at no more than 50mm from each corner and at 150mm maximum centres.

Maximum approved glazed area - System 36/15 = 0.72M²

Glazing with Insulating & Partially insulating glass types:

Flush & Square Beads:

The use of flush and square beads (in addition to splayed beads) is approved for use with insulating and partially insulating glass types only. See page 6.5 for 'Q' Mark approved glass types.

Maximum aperture dimensions remain as described for the particular glass type and glazing system. See pages 6.5 & 6.12 for 'Q' Mark approved maximum aperture dimensions for FD60 applications.

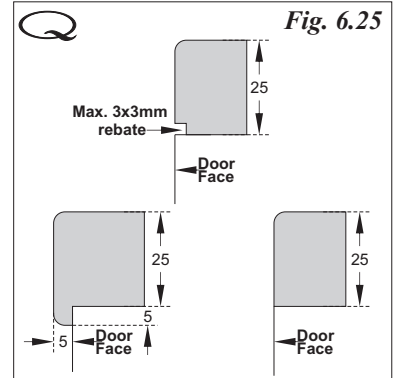

Flush Beads with Insulating or partially insulating Glass Types:

- Apertures must be lined with hardwood of min. 640kg/M³ density (@15% moisture content).
- Intumescent glazing systems described by reference to page 6.12 that are suitable for the required glass thickness may be used for FD60 applications when used with approved insulating or partially insulating glass as identified by reference to page 6.5. for FD60 glass types.

Maximum approved glazed area = 0.72M²

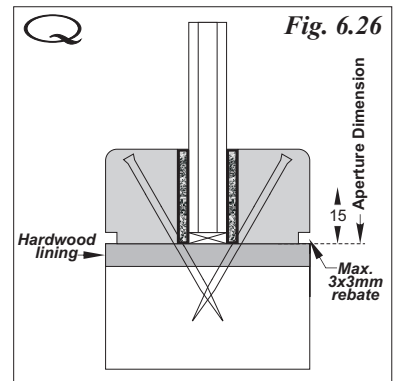

Square Beads (with nibs) used with Insulating or partially insulating Glass Types:

- Apertures must be lined with an intumescent lining that has been tested or assessed for FD60 performance.
- Intumescent glazing systems described by reference to page 6.12 that are suitable for the required glass thickness may be used for FD60 applications when used with approved insulating or partially insulating glass as identified by reference to page 6.5. for FD60 glass types.

Maximum approved glazed area = 0.72M²

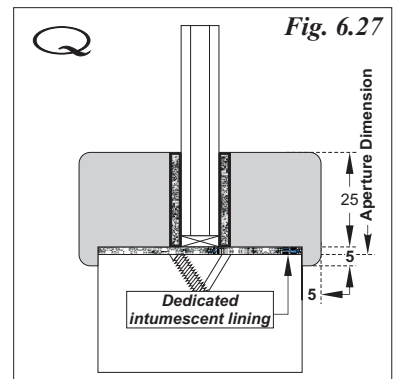

Lorient Polyproducts Ltd. - 'System 36/15' Flexible Gasket

- Lorient System 36/15 may be used with 15mm Pyrostop or 16mm Pyrobel insulating glass types in conjunction with a flush bead, (or square bead with nib). The aperture (or back of the beading) should be lined with a dedicated intumescent lining.
- This detail to be used in reliance upon Lorient Polyproducts Ltd. fire test / assessment data.

Maximum approved glazed area = 0.72M²

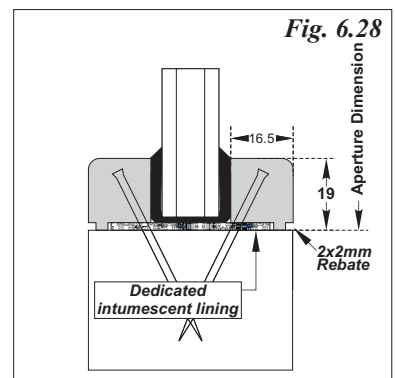

Strebord®

Door Core

Glass & Glazing FD60



Multi Aperture Glazing 1.

Fig. 6.29

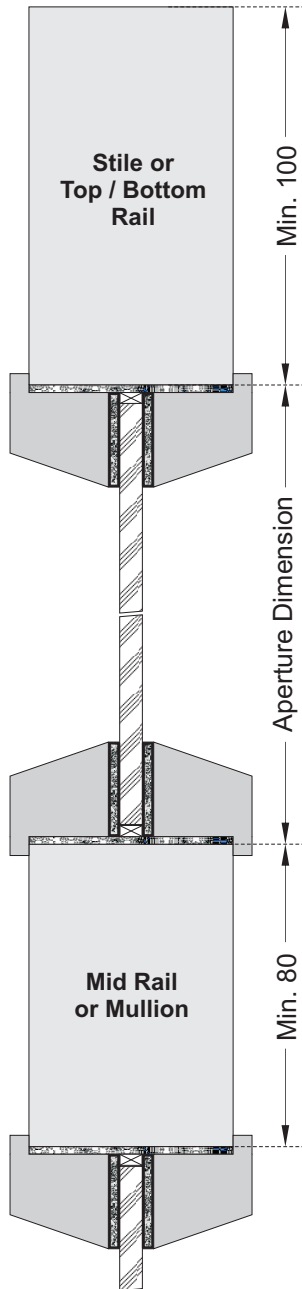

• Subject to limitations with respect of glazed areas and use of suitable glazing systems, there are no limits with regard to the quantity or shape of glazed apertures.

• The minimum dimension from any edge of the door to the nearest sight line of the aperture should not be less than 100mm.

• The dimension between adjacent apertures should not be less than 80mm.

Fig. 6.30

Multi Aperture Glazing 1.

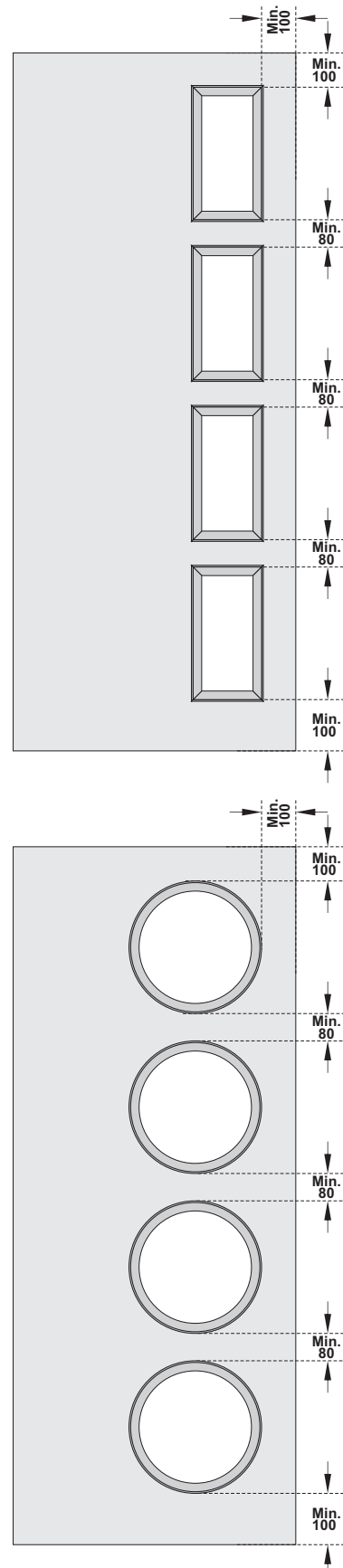

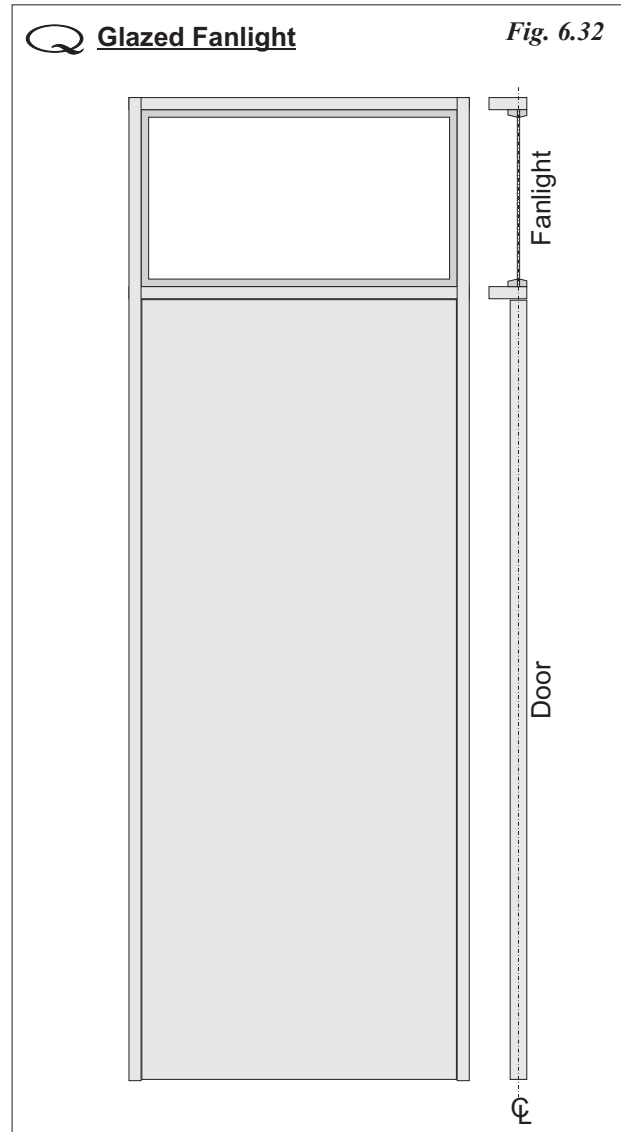
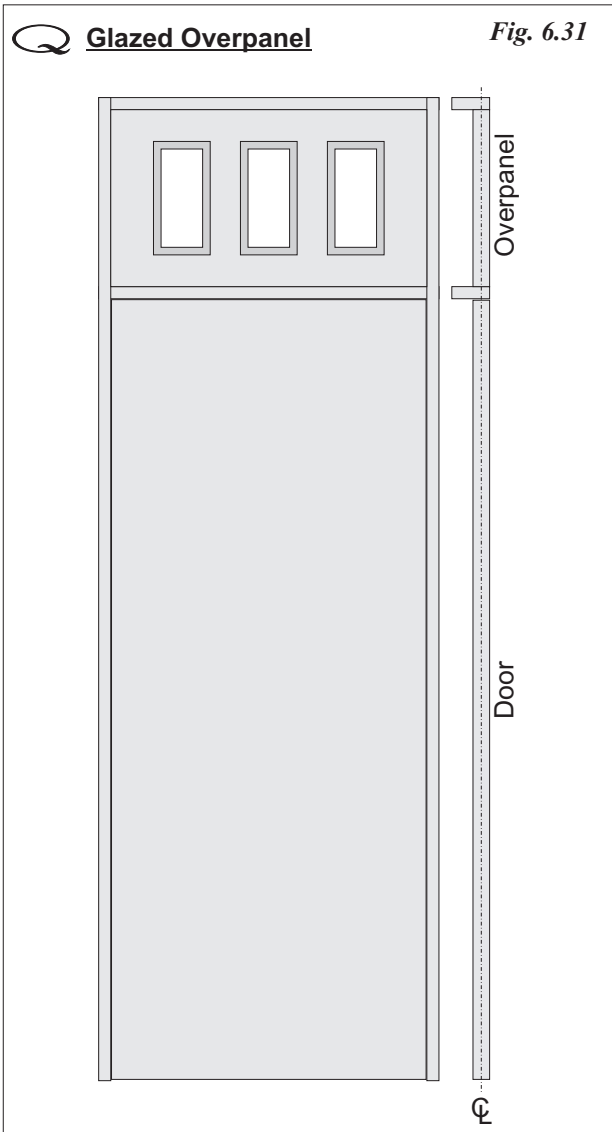

Glazed Overpanel:

Overpanels, with or without transoms to frames, may be glazed subject to the following rules:

- The minimum margin from any edge to the nearest sight line of the aperture for glazing shall not be less than 100mm.
- The minimum dimension between the sight line of adjacent apertures for glazing shall not be less than 80mm.
- The overpanel should be of the same construction as the door and located to align with the door leaves, central in thickness.

Glazed Fanlight & Sidelights:

• Glazed fanlights and side screens may be used in reliance upon fire test / assessment data from others where these are constructed in accordance with tested / assessed details for wood glazed screens.

• For fanlights / side screen a transom rail or mullion should be used of minimum dimensions determined by reference to the glazed screen fire test / assessment data.

• Intumescent sealing systems and beading details should comply with the tested / assessed details for glazed screens.

• The glass in the fanlight / side screen should be located to align to the centre thickness of the door leaves.

• Fire test / assessment data relating to glazed screens is available from glass and intumescent seal manufacturers.

Building Regulations - (England & Wales) - Approved Document 'M' & BS8300 Design of buildings and their approaches to meet the needs of disabled people - Code of Practice *Fig. 6.33*

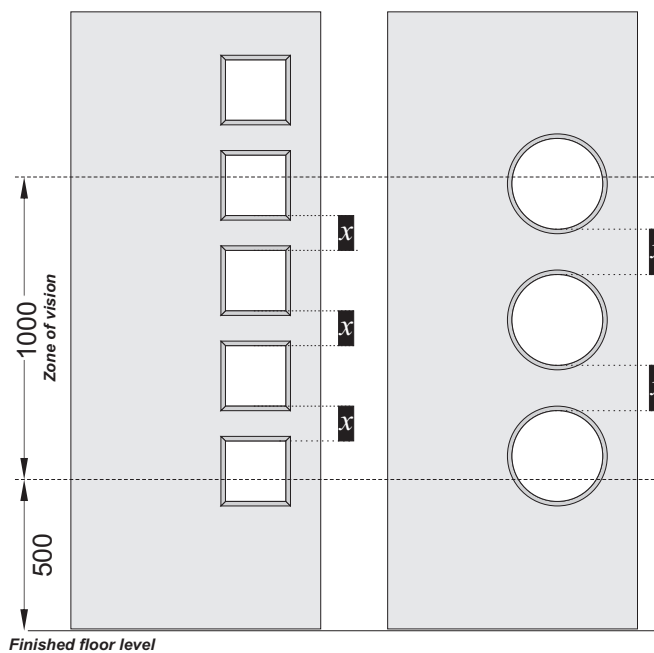
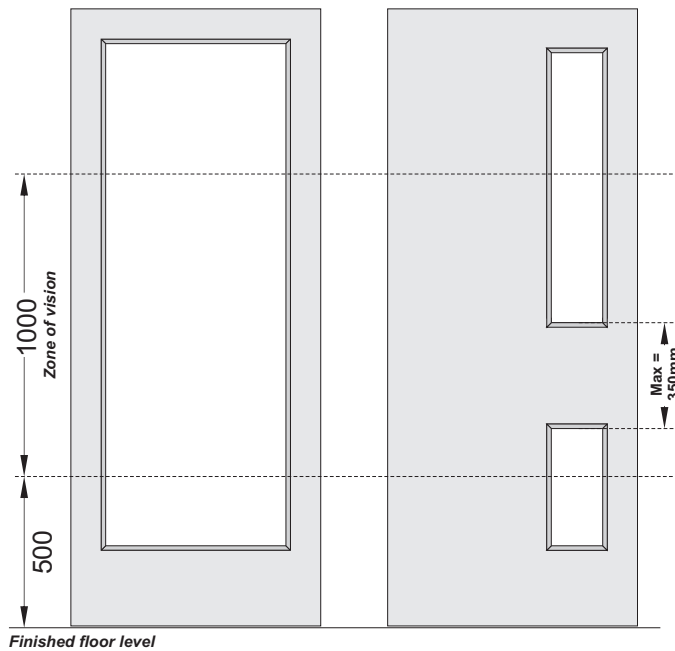

- Specifications may make reference to Building Regulations - England & Wales - Approved Document 'M' and/or BS8300.

- Where required, doors should be glazed to provide for a zone of vision that is suitable to meet the needs of persons of reduced stature and for persons in wheelchairs.

- It is important to recognise that dimensions relate to the clear glass area (aperture dimension after beading). Apertures should be cut to dimensions that anticipate the bead sizes to be used.

- The zone of vision necessary to satisfy this requirement is measured from a height of 500mm above finished floor level and extends to a height of 1500mm above the finished floor level (not the bottom of the door).

- There are no restrictions on the quantity, size or shape of apertures. However, the height dimension of any opaque elements should not exceed 350mm within the 1000mm high zone of vision. The permitted 350mm high opaque height within the zone of vision can be made up of a single rail or multiple rails. Where multiple rails are used then the total opaque height dimension for all rails (*dim. x+x*) should not exceed 350mm.