

## Frame Materials & Specifications:

Details in this section show minimum dimensions for frames for use with fire rated doorsets.

Frame materials for use with fire doors should comply with the recommendations to be found by reference to BS8214 : 1990.

Frame material for FD30 doorsets may be softwood or hardwood of not less than 450kgs/M<sup>3</sup> density @15% moisture content. OR, Min. 700kgs/M<sup>3</sup> MDF.

Frame material for FD60 doorsets must be hardwood of not less than 640kgs/M<sup>3</sup> @ 15% moisture content.

The minimum quality standard for frames for fire doorset applications defined by reference to BS EN942 : 1996 Class J30. (Equating to BS 1186 Pt.1 Class 2).

**NOTE: All timber used for fire rated doorset including frames, lippings & beading, must meet or exceed Class J30 as specified in BS EN 942 : 2007, any defects should be repaired and, as far as possible, orientated away from areas of intumescent seal activation.**

Frames should be installed plumb and square and assembled with mortice and tenon, mitred or half lap joints with mechanical assembly fixings (e.g. nailed or screwed). All joints should be of a tight fit.

**NOTE: Joints may be glued and screwed.**

Unless otherwise stated in project specifications: The moisture content of material used for frames should be 9 - 13% average. moisture content at the time of handover, as required by reference to BS EN 942 : 1996 for internal joinery designed for use in heated buildings providing room temperatures of 12°C to 21°C.

**NOTE:**

**For 'Q' Mark fire rated doorsets refer to 'Section 2 - Strebord Fire Door Applications'.**



**FSC Falcon Panel Products Ltd., recommends the use of timber obtained from FSC approved sources.**

## Structures:

It is the Designers responsibility to ensure that structures to receive fire doorsets comply with National and Local Regulations and that they are suitable for the design performance.

**NOTE: Refer to the various parts of BS5588 (BS9999) for further guidance.**

The fire test / assessment data applicable to Strebord<sup>®</sup> based doorsets anticipates that the doorsets will be fitted into blockwork, brickwork, concrete, (or similar). OR, timber stud partitioning.

Where doorsets are to be fitted into metal stud partitioning, the hollow metal stud at the doorset positions should be filled with softwood unless the partitioning manufacturer can provide for fire test / assessment data to demonstrate that this is not necessary.

The finished partition thickness shall not be less than the partition thickness described for the door frame.

The gap between the frame and the surrounding structure should be treated in accordance with the recommendations to be found by reference to BS 8214 : 2007 according to performance.

## Architrave:

The use of architrave is recommended for fire doors. These should be Min. 12mm thickness and conform with the material specifications applicable to frames for the relevant fire performance. The architrave should cover the gap between the frame and the wall providing for a min. 5mm cover over the wall and nom. 15mm cover over the frame nose.

Where the doorset is fitted within the partition thickness, the architrave should be scribed on site to suit the wall conditions.

Intumescent mastics, ceramic cords and similar products may be used in lieu of architrave where these have a proven performance under fire test conditions with wood doorsets. These materials must be used strictly in accordance with the manufacturers handling and use instructions.

## Minimum Recommended Frame Dimensions FD30 Doorsets.

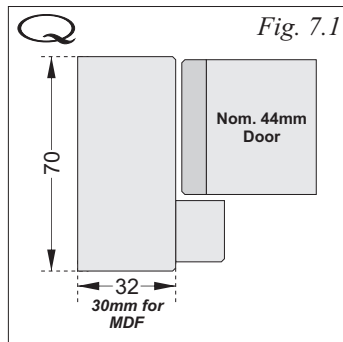

### Recommended minimum frame dimensions for FD30 Single Action Doorsets.

- Frame material to be softwood or hardwood of minimum 450kg/M<sup>3</sup> density (@15% moisture content), complying with Class J30 BS EN 942 : 2007.

- 700kg/M<sup>3</sup> density MDF frames may be used but with maximum door leaf dimensions limited to 2350 high x 960mm wide.

**NOTE:** The 32mm section dimension fro the frame is reduced from 32mm to 30mm for use with MDF frames.

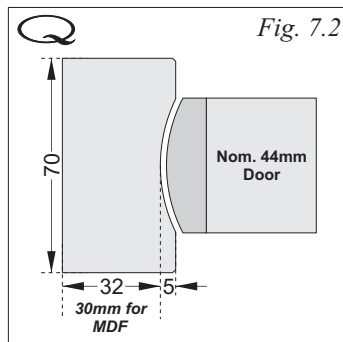

### Recommended minimum frame dimensions for FD30 Double Action - Hanging Jamb

- Frame material to be softwood or hardwood of minimum 450kg/M<sup>3</sup> density (@15% moisture content), complying with Class J30 BS EN 942 : 2007.

- 700kg/M<sup>3</sup> density MDF frames may be used but with maximum door leaf dimensions limited to 2350 high x 960mm wide.

**NOTE 1:** The 32mm section dimension fro the frame is reduced from 32mm to 30mm for use with MDF frames.

**NOTE 2:** The radius at the hanging stile will usually be determined by the location of the double action pivot centre. A 50mm radius to the door edge will suit most popular brands of double action fittings, with a 52mm radius scallop in the frame.

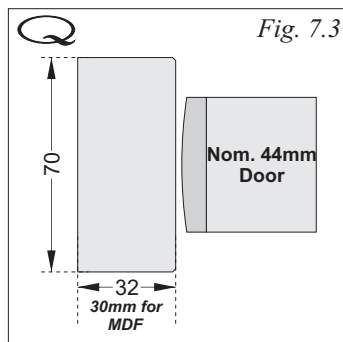

### Recommended minimum frame dimensions for FD30 Double Action - Closing Jamb

- Frame material to be softwood or hardwood of minimum 450kg/M<sup>3</sup> density (@15% moisture content), complying with Class J30 BS EN 942 : 2007.

- 700kg/M<sup>3</sup> density MDF frames may be used but with maximum door leaf dimensions limited to 2350 high x 960mm wide.

**NOTE:** The 32mm section dimension fro the frame is reduced from 32mm to 30mm for use with MDF frames.

## Minimum Recommended Frame Dimensions FD60 Doorsets.

**Q Recommended minimum frame dimensions for FD60 Single Action Doorsets.**

- Frame material to be hardwood of minimum 640kg/M<sup>3</sup> density (@15% moisture content), complying with Class J30 BS EN 942 : 2007.

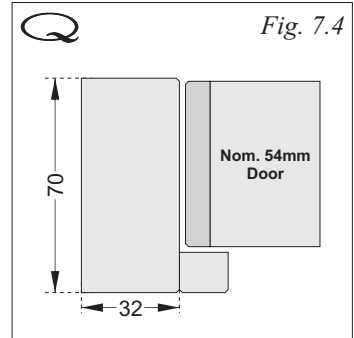

**Q Recommended minimum frame dimensions for FD60 Double Action - Hanging Jamb**

- Frame material to be hardwood of minimum 640kg/M<sup>3</sup> density (@15% moisture content), complying with Class J30 BS EN 942 : 2007.

**NOTE:** The radius at the hanging stile will usually be determined by the location of the double action pivot centre. A 50mm radius to the door edge will suit most popular brands of double action fittings, with a 52mm radius scallop in the frame.

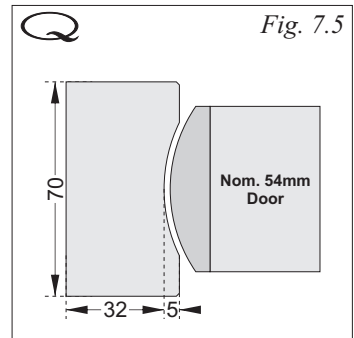

**Q Recommended minimum frame dimensions for FD60 Double Action - Closing Jamb**

- Frame material to be hardwood of minimum 640kg/M<sup>3</sup> density (@15% moisture content), complying with Class J30 BS EN 942 : 2007.

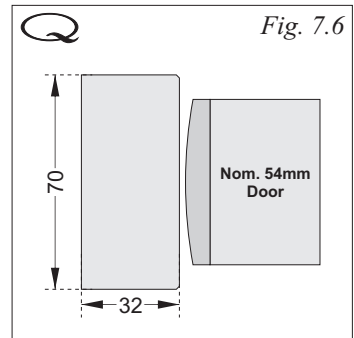

# Strebord®

Door Core

## Doorframes

### Softwood and Hardwoods for use with frames for Strebord<sup>44</sup> based doors.

- 1/ The following lists of Softwoods & Hardwoods is culled from BS EN 942 : 2007.
- 2/ These lists show the nominal density for the species @ 15% moisture content.
- 3/ The lists identify suitability for fire door applications based upon BS8214 : 1990 recommendations and current fire test / assessment data.
- 4/ The lists are provided as a guide to users and may not describe all available softwoods or hardwoods.

#### Frame Materials - Softwoods

| Item | Species             | Latin Name                                      | Characteristics   | Avg. Density         | Fire Door |      |
|------|---------------------|---|---|----------------------|-----------|------|
|      |                     |   |   |                      | FD30      | FD60 |
| 1    | Douglas Fir         | <i>Pseudotsuga menziesii</i>                    | Pale reddish brown heartwood, paler sapwood. Growth rings clearly defined and inclined to show through paint. Discolours in contact with ferrous metal. Non-ferrous fittings and fastenings are recommended. Long clear lengths available.                                | 530Kg/M3             | OK        | NR   |
| 2    | Hemlock, western    | <i>Tsuga heterophylla</i>                       | Pale brown in colour. Growth rings distinguishable. Straight grain, fine even texture. Shipments include amabilis fir (less dense, less strong). Good paint performance in service. Long clear lengths available.   | 470Kg/M3 to 500Kg/M3 | OK        | NR   |
| 3    | Parana Pine         | <i>Araucaria angustifolia</i>                   | Golden brown, sometimes with red streaks. Straight grain, fine uniform texture, generally available knot free. Liable to distort on machining. Good paint performance in service.   | 550Kg/M3             | OK        | NR   |
| 4    | Pine, lodgpole      | <i>Pinus contorta</i>                           | Heartwood yellow to pale brown tinged with red, paler sapwood. Where present, knots are small and tight. Resinous smell. Fine even texture, straight grained. Paints well.  | 470Kg/M3             | NR        | NR   |
| 5    | Pine, ponderosa     | <i>Pinus ponderosa</i>                          | Very wide pale yellow sapwood. Dark yellow to reddish brown heartwood, with fine prominent resin ducts. Paints well, but resin exudation can be troublesome.  | 480Kg/M3             | OK        | NR   |
| 6    | Pine, southern      | <i>Pinus echinata, Pinus taeda &amp; others</i> | Yellow / reddish brown resinous heartwood, paler sapwood. Growth rings distinct, course appearance. Paints fairly satisfactorily  | 590Kg/M3             | OK        | NR   |
| 7    | Pine, sugar         | <i>Pinus lambertiana</i>                        | Pale straw to reddish brown heartwood, white sapwood. Soft even texture. Paints well.   | 430Kg/M3             | NR        | NR   |
| 8    | Redwood: Scots pine | <i>Pinus sylvestris</i>                         | Pale yellowish brown to red brown heartwood, paler sapwood. Medium texture. Growth rings clearly marked. Good paint performance in service.   | 510Kg/M3             | OK        | NR   |
| 9    | Western Red Cedar   | <i>Thuja plicata</i>                            | Variable reddish brown heartwood, distinct white sapwood. Straight grain, course texture. Discolours in contact with ferrous metal if damp. Non-ferrous fittings and fastenings are recommended. Good paint performance in service. Particularly suited for exterior use. | 390Kg/M3             | NR        | NR   |
| 10   | Whitewood           | <i>Picea abies and Abies alba</i>               | White to pale yellowish brown. Straight grain, rather fine texture. Good paint performance in service.  | 470Kg/M3             | NR        | NR   |

Avg. Density = Average density @ 15% moisture content.

#### NOTE:

The densities for Softwoods and Hardwoods described in BS EN 942 are the average densities for the particular species at 15% moisture content.

Some species listed as 'NR' may be used for FD30 and FD60 applications where the frame material is selected from available stocks to suit the fire performance density requirement. e.g. American Cherry selected to provide for a minimum density of 640kg/M<sup>3</sup> may be used for FD60 applications.

Similarly, materials listed as 'OK' for fire door applications must provide for the minimum density requirement to suit the fire performance.

**Frame Materials - Hardwoods**

| Item | Species                         | Latin Name  | Characteristics   | Avg. Density         | Fire Door |          |
|------|---------------------------------|---|---|----------------------|-----------|----------|
|      |                                 |   |   |                      | FD30      | FD60     |
| 1    | Abura                           | <i>Hallan ciliata</i>                                   | Pale brownish coloured heartwood and sapwood, plain appearance. Medium / fine texture. Tendency to split on nailing. Stains well  | 580Kg/M3             | OK        | NR       |
| 2    | Afromosia                       | <i>Pericopsis elata</i>                                 | Deep brown heartwood, pale brown sapwood. Medium / fine texture. Discolours in contact with ferrous metal if damp. Pre-bore before nailing.   | 710Kg/M3             | OK        | OK       |
| 3    | Afzelia                         | <i>Afzelia spp.</i>                                     | Reddish brown timber, straw coloured spwood. Grain often interlocked, texture course. Pre-bore before nailing. Can stain masonry and textiles if damp.  | 830Kg/M3             | OK        | OK       |
| 4    | Agba                            | <i>Gossweilerodendron balsamiferum</i>                  | Pale pinkish brown heartwood of uniform appearance, sapwood slightly paler (border sometimes indistinct). Medium texture. Resin, resinous odour frequent.   | 510Kg/M3             | OK        | NR       |
| 5    | Ash, American                   | <i>Fraxinus americana, F. nigra &amp; others.</i>       | Coarse texture. Sapwood nearly white, White ash heartwood greyish brown, tough. Black ash darker, lower density, less tough.  | 660Kg/M3             | OK        | OK       |
| 6    | Ash, European                   | <i>Fraxinus excelsior</i>                               | Generally white to pale brown. Medium / course texture. Very good bending timber, very tough.   | 710Kg/M3             | OK        | OK       |
| 7    | Beech, European                 | <i>Fagus sylvatica</i>                                  | Pale reddish brown; if steamed, pink. Fine even texture. Good bending. Stains, polishes well.   | 720Kg/M3             | OK        | OK       |
| 8    | Birch, yellow                   | <i>Betula alleghaniensis</i>                            | Wide variation in colour from cream to reddish brown, can include sweet birch (denser, darker). Fine even texture. Stains and polishes well.  | 700Kg/M3             | OK        | OK       |
| 9    | Cedar, Central & South American | <i>Cedrela odorata, C. fissilis</i>                     | Colour pale to dark reddish brown and properties highly variable. Very low density. Occasional interlocked grain, coarse texture. Fragrant odour. Resin exudation, resin pockets may occur.   | 480Kg/M3             | OK        | NR       |
| 10   | Cherry, American                | <i>Prunus serotina</i>                                  | Colour varies from pale straw to reddish brown. Straight fine grain, fine texture. Pith flecks and small gum pockets are common. Stains, polishes well.   | 590Kg/M3             | OK        | NR       |
| 11   | Chestnut, sweet                 | <i>Castanea sativa</i>                                  | Yellowish brown heartwood, similar to oak. Sapwood distinct. Course texture, tendency to spiral grain. Discolours in contact with ferrous metal if damp. Non-ferrous fittings or fastenings are recommended.  | 560Kg/Ms             | OK        | NR       |
| 12   | Elm                             | <i>Ulmus spp.</i>                                       | Pale greyish brown. Straight but sometimes interlocked grain, course texture. Good bending properties.  | 580Kg/M3             | OK        | NR       |
| 13   | Guarea                          | a/ <i>Guarea cedrata</i><br>b/ <i>Guarea thompsonii</i> | Can be brought separately. Pinkish brown colour, sapwood pale. Fine texture, often interlocked grain. a/ occasionally exudes resin.   | 590Kg/M3<br>640Kg/M3 | OK        | NR<br>OK |
| 14   | Idigbo                          | <i>Terminalia ivorensis</i>                             | Yellowish to pale yellowish brown colour heartwood, sapwood somewhat paler. Coarse texture. Discolours in contact with ferrous metal, can stain masonry if damp. Non-ferrous fittings or fastenings are recommended.  | 560Kg/M3             | OK        | NR       |
| 15   | Iroko                           | <i>Milicia excelsa and m. regia</i>                     | Colour varies from yellowish brown to dark brown, with pale yellow sapwood. Interlocked grain, coarse texture. Very hard, strong.   | 660Kg/M3             | OK        | OK       |
| 16   | Keruing                         | <i>Dipterocarpus spp.</i>                               | Numerous species of similar characteristics. Pinkish brown to dark brown heartwood, plain appearance. Sapwood grey. Straight grain, occasionally interlocked. Exudes resin, sometimes making finishing troublesome. Prone to severe distortion during drying. | 740Kg/M3             | OK        | OK       |

# Strebord®

Door Core

## Doorframes

### Frame Materials - Hardwoods

| Item | Species                  | Latin Name                                    | Characteristics  | Avg. Density                                  | Fire Door |          |
|------|--------------------------|---|--|---|-----------|----------|
|      |                          |   |  |   | FD30      | FD60     |
| 17   | Lauan, Meranti, Seraya   | <i>Shorea spp.</i><br><i>Parashorea spp.</i>  | Name depends on origin: Philippines, Malaysia/Indonesia Sabah respectively. Produced from numerous species, the timber is sold in a wide variety of colour (dark red, red, light red, yellow, white) with widely varying characteristics. Those with higher density are generally stronger, stiffer and more durable than those with lower density. Interlocked grain, coarse texture. | Dark Red<br>710Kg/M3<br>Light Red<br>550Kg/M3 | OK        | OK<br>NR |
| 18   | Mahogany, African        | <i>Khaya spp.</i>                             | Reddish brown heartwood, yellowish brown sapwood. Interlocked grain, moderately coarse texture.  | 530Kg/M3                                      | OK        | NR       |
| 19   | Mahogany, American       | <i>Swietenia spp.</i>                         | Pale to dark reddish brown. Some interlocked grain, texture slightly coarse: gives excellent finish.   | 560Kg/M3                                      | OK        | NR       |
| 20   | Makore                   | <i>Teiaghemella heckelii</i>                  | Lustrous, pinkish brown to dark red heartwood, paler sapwood. Straight grain, fine texture. Discolours in contact with ferrous metal. Tends to split on nailing.   | 640Kg/M3                                      | OK        | OK       |
| 21   | Maple, rock              | <i>Acer saccharum</i>                         | Pale brown heartwood, white sapwood. Straight grain, fine texture. A strong, taut timber, bends well. Stains, polishes well.   | 740Kg/M3                                      | OK        | OK       |
| 22   | Maple, soft              | <i>Acer rubrum,</i><br><i>saccharinum</i>     | A. Creamy white heartwood, sapwood indistinct. Similar to rock maple but softer, less strong.  | 610Kg/M3                                      | OK        | NR       |
| 23   | Niangon                  | <i>Heritiera utilis,</i><br><i>densiflora</i> | H. Pale sapwood, pink to reddish-brown heartwood. Interlocked grain gives stripey appearance, affects machining.   | 640Kg/M3                                      | OK        | OK       |
| 24   | Oak American, red        | <i>Quercus spp</i>                            | Colour varies, depending on species, from pale yellow brown to reddish mid brown. Sapwood distinct, paler. Straight grain, all species medium texture except European, which may be coarse.  | Am.Red<br>790Kg/M3                            | OK        | OK       |
| 25   | Oak American, white      | <i>Quercus spp</i>                            | Discolours in contact with ferrous metals. Non-ferrous fittings and fastenings are required. Nailing difficult, pre-bore. Difficult to dry, tendency to check, split and honeycomb.  | Am.White<br>770Kg/M3                          | OK        | OK       |
| 26   | Oak European             | <i>Quercus spp</i>                            | Pale straw coloured. Interlocked grain, moderately coarse even texture. A stable, lightweight, easy to work timber. Stains well. Not suitable for stairs.  | European<br>720Kg/M3                          | OK        | OK       |
| 27   | Oak Japanese             | <i>Quercus spp</i>                            | Yellowish to olive brown heartwood with some dark streaks, whitish sapwood. Straight grain, fine even texture. Smooth finish, good nailing and staining.   | Japanese<br>670Kg/M3                          | OK        | OK       |
| 28   | Obeche                   | <i>Triplochiton scleroxylon</i>               | White to pale straw colour. Straight grain, fine texture. Splits on nailing. Stains well. Not suitable for stairs.   | 390Kg/M3                                      | NR        | NR       |
| 29   | Poplar American - yellow | <i>Liriodendron tulipifera</i>                | White to yellowish, lustrous. Generally straight grain, fine even texture.   | 510Kg/M3                                      | OK        | NR       |
| 30   | Ramin                    | <i>Gonystylus spp.</i>                        | Golden brown heartwood sometimes with dark markings, pale yellowish brown sapwood. Straight or wavy grain, coarse texture. Very stable. Pre-boring recommended for nailing.  | 670Kg/M3                                      | OK        | OK       |
| 31   | Sapele                   | <i>Entandrophragma cylindricum</i>            | Reddish or purplish brown heartwood, pale sapwood. Interlocked grain, open texture.  | 640Kg/M3                                      | OK        | OK       |
| 32   | Sycamore                 | <i>Acer pseudoplatanus</i>                    | Bronze brown heartwood, with occasional black streaks, distinct buff coloured spwood. Interlocked grain, fine texture.   | 630Kg/M3                                      | OK        | NR       |
| 33   | Teak (Burma)             | <i>Tectona grandis</i>                        | Rich dark brown heartwood, pale sapwood. Grain varies from straight to curly, texture coarse.  | 660Kg/M3                                      | OK        | OK       |
| 34   | Utile                    | <i>Entandrophragma utile</i>                  | Sapwood whitish, heartwood dark brown with fine blackish veining. Straight grained, coarse texture. Difficult to polish.   | 660Kg/M3                                      | OK        | OK       |
| 35   | Walnut (African)         | <i>Lovoa trichilioides</i>                    |  | 560Kg/M3                                      | OK        | NR       |
| 36   | Walnut (American)        | <i>Juglans nigra</i>                          |  | 660Kg/M3                                      | OK        | OK       |
| 37   | Wenge                    | <i>Millettia laurentii</i>                    |  | 880Kg/M3                                      | OK        | OK       |

Avg. Density = Average density @ 15% moisture content.

**Wood Doors with Metal Frames - Considerations:**

Under fire conditions, steel (and most metals) will heat up and expand on the fire side first. Most metals are good conductors of heat, and the temperature will rise quite rapidly on the non fire side unless action is taken to slow the transfer of heat.

When wood and wood based products are subjected to fire conditions, any moisture in the product will attempt to move away from the heat source and will be evident as 'sweating' on the non fire side. Further, the wood on the fire side will char. The charring provides for a fire retardant layer but this is also associated with shrinkage on the fire side.

The effect of these conditions is that the steel will bow towards the fire while wood based products will bow in the opposite direction. If the differential bowing becomes excessive gaps will be created between the door and the frame giving rise to failures under fire test conditions. In addition, heat that is readily conducted through metal products can reach sufficiently high temperatures to cause ignition of wood based products on the non fire side.

One method for delaying the transfer of heat through a metal product is to provide for a heat absorbing facility. In the case of metal door frames, this can be achieved back filling hollow metal frames with cementitious materials e.g. mortar. Gypsum boards have also been successfully used for this purpose.

Notwithstanding the above, Strebord<sup>®</sup> based doors have been successfully tested to FD60 performances (BS476 Pt.22) with hollow steel frames.

**Strebord<sup>54</sup>® Doors with Steel Frames:**

Strebord<sup>154</sup>® doors can be used with mild steel or Grades 304 or 316 stainless steel frames for FD60 applications subject to the following:

- Frames to be hollow metal or backfilled with mortar or concrete.
- The frame is to be manufactured using 1.6mm (+100% - 0% mild steel, Grade 304 or Grade 316 stainless steel.
- The frame section is to be as detailed by reference to *Fig. 7.7* subject to the following permitted variants:  
 Dim. 'Y' = +/- 50%  
**(providing the frame reveal dimensions are maintained)**  
 Dim. 'X' = +/- 30%
- Frame fixings must be of an appropriate type and length for the structural medium into which they are fixed and must include a minimum of 1No. fixing for no more than 600mm of vertical edge, with a fixing no more than 350mm from the top and bottom corners. Two fixings are required to the frame head.
- Gaps between the door frame and the structural opening must be protected using proprietary materials (e.g intumescent mastics) that have been successfully tested for this applications.

**NOTE: For dimensional limitations, configurations and intumescent sealing requirements see Sections 2 and 4.**

