

General:

Strebord[®] is a GDC (Graduated Density Chipboard) product providing for universal screw fixing without the necessity to provide for additional timber blocking with the exception of provision for additional timber blocking to receive load bearing double and single action pivot fixing.

All hardware fitted to Strebord[®] doors should be fixed with fully threaded 'Twinfast' or Chipboard screws. The screw size for load bearing items should be. Min. 1 1/2in. No.8 fixing screws. Pilot holes should be drilled to receive fixings.

For use with fire rated doorsets, the following recommendations apply:

a/ Reference should be made to BS8214 : 2007. Code of Practice for Fire Door Assemblies with non metallic leaves.

b/ Reference should be made to the 'Hardware for Timber Fire and Escape Doors' Code of Practice published jointly by the DHF (Door & Hardware Federation and the GAI (Guild of Architectural Ironmongery).

Fire Door Applications:

NOTE: Use of items of hardware that are listed under the 'Q' Mark product assurance scheme as suitable for use with wood fire doors is strongly recommended. For 'product assured' items, the fixing instructions provided by the hardware manufacturer should be strictly adhered to and these instructions take precedence over BS8214 and Code of Practice general recommendations in the event of any conflict.

Strebord[®] like other wood and wood based doors rely on the core material to erode at a predictable rate for their fire performance. Intumescent seals fill gaps around the door(s) that may occur as a result of shrinkage or distortion under fire conditions. The removal of core and intumescent material to accommodate hardware creates weaknesses that can be exploited under attack by fire. Large areas of metal, when used with a wood door can induce excessive distortion and premature failure. It is recommended that hardware is selected with care in consideration of these risks.

It is not unusual for hardware to be specified prior to the specification of the doors and without knowledge, at the time of preparation of hardware schedules, of the fire performances that need to be satisfied. It is a Designer's responsibility to ensure that the doorset designs meet the requirements of national and local regulations for the purpose of fire certification. (See: BS5588 or BS9999).

Strebord[®] like other wood based products provides for very good insulation performances with a potential to provide for an insulation performance equal to the integrity performance. (See BS476 Pt.22). Metal passing through the door from one face to another creates a path for thermal bridging, (i.e. *The transfer of heat from one side of the door to the other*), this will reduce the insulation properties of the door and in extreme cases may give rise to ignition on the non fire face of the door.

Under BS476 Pt.20 fire test conditions the pressure 'normal' in the furnace occurs at (approx) 1000mm above floor level. Areas of door above the normal are subjected to increasing positive pressure from the furnace side while areas below the normal are subjected to negative pressure from the furnace side. This results in 'cold' air entering the furnace under the door with a cooling effect on this edge. Hardware items, particularly locks & latches, should be positioned below the 'normal' where possible.

NOTE: The pressure normal is lowered to 500mm above floor level for testing to BS EN 1634-1.

Where the door / frame seals are interrupted to receive hardware it may be necessary to provide for replacement sealing. The use of pressure intumescent seals (e.g. Palusol P100 or Graphite) may be unsuitable for this purpose due to a risk that pressure seals could compete with door / frame seals in an unpredictable manner. The replacement intumescent sealing should generally be of the low pressure type. (Usually Phosphate based). Low pressure intumescent is available in sheet form (often pre cut to suit particular items of hardware).

Examples:

- Interden Gaskets - Lorient Polyproducts Ltd.
- Therm-a-Strip - Intumescent Seals Ltd.
- Pyrostrip 300 - Mann McGowan Ltd.
- Norseal Ltd.

Most intumescent mastics are of the low pressure type and are generally suitable for this application.

NOTE: The remaining text making reference to 'Intumescent Gaskets' include for the sheet material and mastic.

Fire Door Applications - Hanging devices - Hinges:

Hinges - FD30:

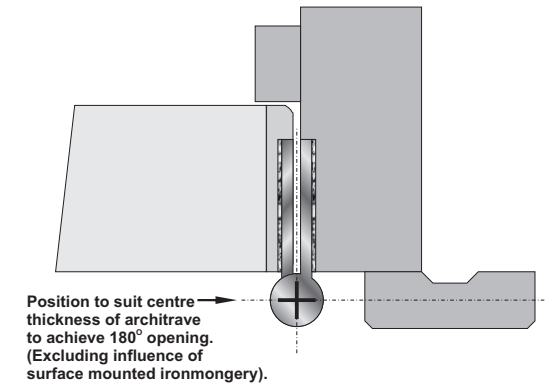

Hinges - FD60:

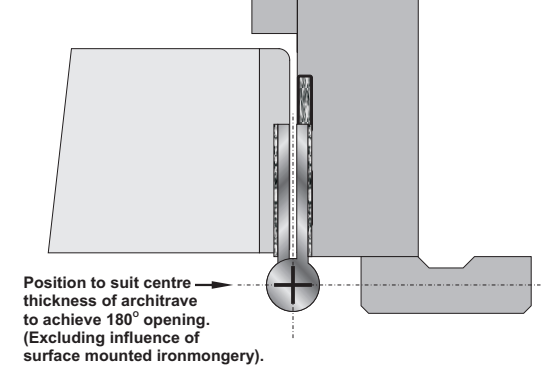

Hinge Specification FD30:

Blade Height	90~120mm
Blade Width (excluding knuckle)	32~35mm
Blade Thickness	2.5 ~ 4mm
Fixings	Min. 4No. 38mm long fully threaded 'twinfast' or chipboard screws per hinge blade.
Materials	Brass, steel or stainless steel
Intumescent Protection	1mm Interdens - Dufalite Developments Ltd. <i>Required under all hinge blades for door leaves greater than 2670mm high.</i> 1mm MAP paper - Lorient Polyproducts Ltd. 1mm Pyrostrip 300 - Mann McGowan Fabrications Ltd. 1mm Therm-A-Strip - Intumescent Seals Ltd.
Hinge Positions: Leaf dimensions <2400mm	Top = 150 ~ 180mm from top of door. Centre: Min. 200mm from top hinge to central between top & bottom hinge. Bottom: 180 ~ 250mm from bottom of door.
Hinge Positions: Leaf dimensions >2400mm	Top = 150 ~ 180mm from top of door. Centre Hinges: 2No. Equispaced between top and bottom hinges Bottom: 180 ~ 250mm from bottom of door.

Hinge Specification FD60:

Blade Height	90~120mm
Blade Width (excluding knuckle)	30~35mm
Blade Thickness	2.5 ~ 4mm
Fixings	Min. 4No. 38mm long fully threaded 'twinfast' or chipboard screws per hinge blade.
Materials	Steel or stainless steel
Intumescent Protection	1mm Interdens - Dufalite Developments Ltd. 1mm MAP paper - Lorient Polyproducts Ltd. 1mm Pyrostrip 300 - Mann McGowan Fabrications Ltd. 1mm Therm-A-Strip - Intumescent Seals Ltd.
Hinge Positions: Leaf dimensions <2400mm	Top = 150 ~ 180mm from top of door. Centre: Min. 200mm from top hinge to central between top & bottom hinge. Bottom: 180 ~ 250mm from bottom of door.
Hinge Positions: Leaf dimensions >2400mm	Top = 150 ~ 180mm from top of door. Centre Hinges: 2No. Equispaced between top and bottom hinges Bottom: 180 ~ 250mm from bottom of door.

In addition, the hinges should provide for the appropriate BS EN 1935 : 2002 performance according to the door weight and anticipated usage.

The hinge knuckle centre should be set as near to the door face as possible to minimise the 'door growth' during operation. (See 'Growth Formula' - Section 8 - Coordination).

A hinge knuckle centre at the centre line of the architrave thickness will allow for 180° opening (excluding the influence of other surface mounted ironmongery).

Pilot holes should be drilled to receive hinge fixing screws with hinges fixed to the door leaf using Min. 1 1/2in. No.8 fully threaded 'Twinfast' or course threaded chipboard screws.

Fire Door Applications - Hanging devices - Floor Mounted Closers - Double Action:

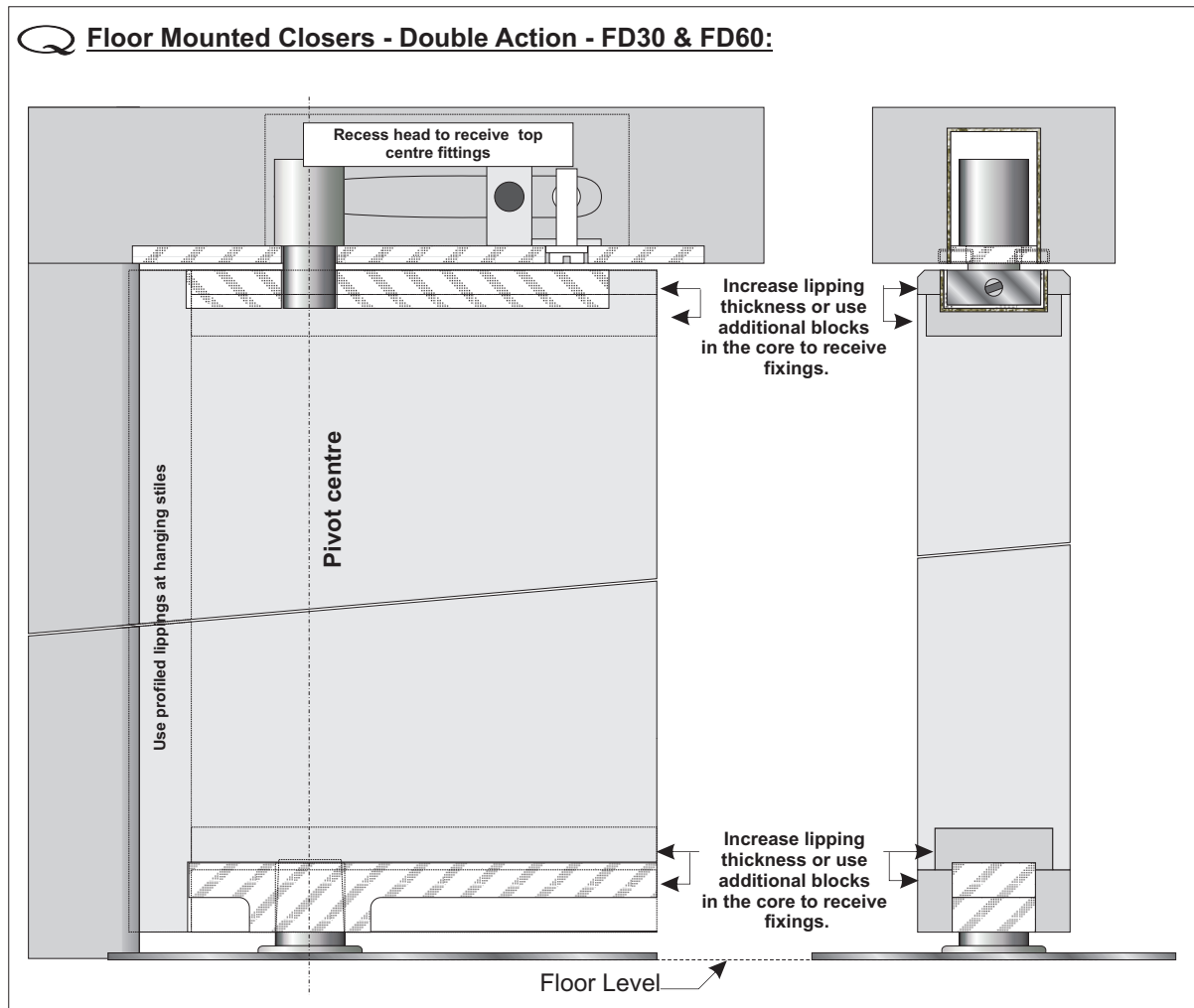

Double Action Pivots FD30 & FD60:

Automatic closing devices must be tested or assessed to the required fire performance when tested to BS 476 Pt.22 : 1987 or BS EN 1634-1 : 2000 with wood doors.

The top pivots to floor spring assemblies must be protected with intumescent gaskets as described for hinges but in 2mm thickness. Alternatively a dedicated intumescent pack provided by the floor spring supplier may be used.

The above illustration indicates use of the DORMA BTS series floor mounted closer with double action fittings.

NOTE : Use of floor mounted closing devices obtained from sources that are subject to the 'Q' Mark product assurance scheme is recommended.

Hanging stile lippings should be profiled (to suit pivot centre). Use of top and bottom edge double lippings (or suitably sized 'T' lippings) to receive pivot fixings is recommended.

NOTE: Alternatively additional hardwood blocking may be used at the pivot location positions to provide for improved fixing of the load bearing elements.

Pilot holes should be drilled to receive screw fixings. Min. 1 1/2in. No.8 fully threaded 'Twinfast' or course threaded chipboard screws should be used for fixing.

NOTE: Bottom strap fittings can be over recessed to provide for required under door clearances.

NOTE: Transom mounted double action closers are not approved for 'Q' Mark applications but may be used (subject to further test / assessment). (e.g. Dorma RTS 85).

Fire Door Applications - Hanging devices - Floor Mounted Closers - Single Action:

Q Floor Mounted Closers - Single Action - FD30 & FD60:

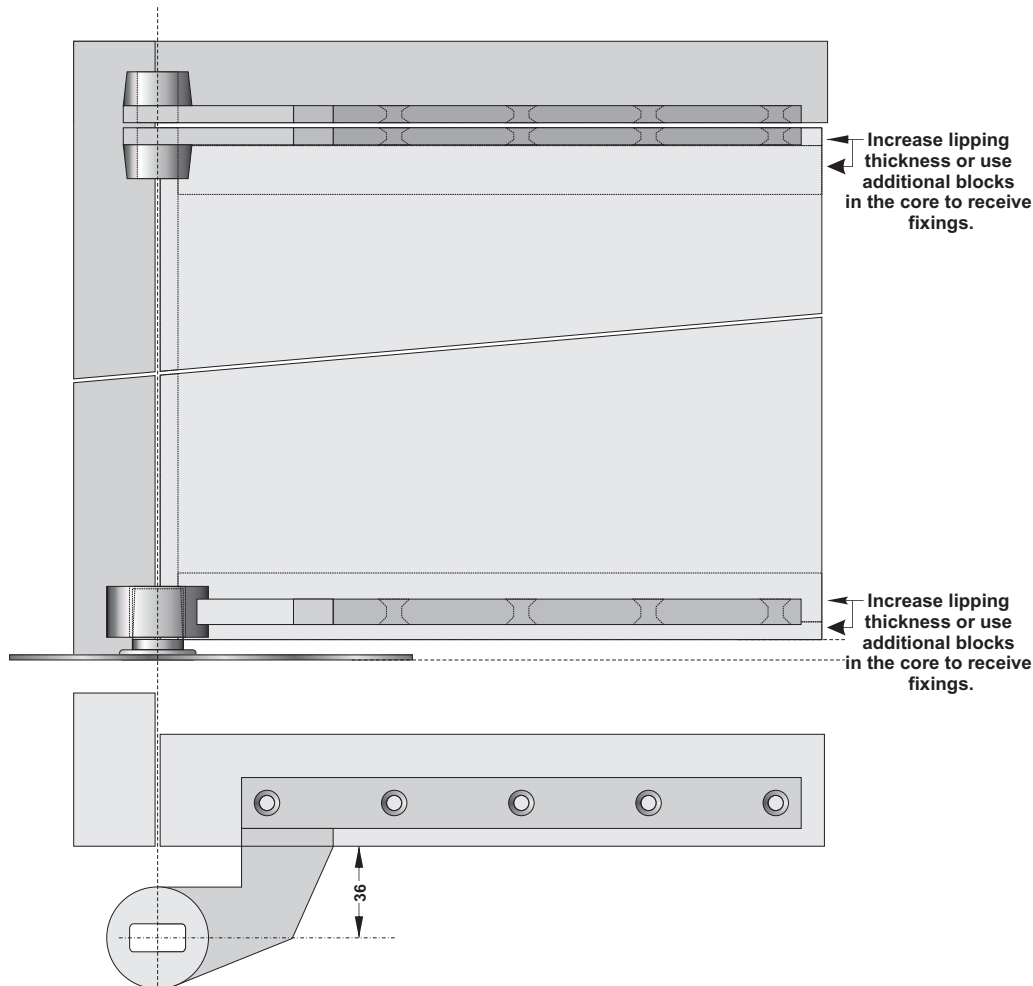

Single Action Pivots FD30 & FD60:

Automatic closing devices must be tested or assessed to the required fire performance when tested to BS 476 Pt.22 : 1987 or BS EN 1634-1 : 2000 with wood doors.

The top pivots to floor spring assemblies must be protected with intumescent gaskets as described for hinges but in 2mm thickness. Alternatively a dedicated intumescent pack provided by the floor spring supplier may be used.

The above illustration indicates use of the DORMA BTS series floor mounted closer with single action fittings.

NOTE : Use of floor mounted closing devices obtained from sources that are subject to the 'Q' Mark product assurance scheme is recommended.

Use of top and bottom edge double lippings (or suitably sized 'T' lippings) to receive strap fixings is recommended.

NOTE: Alternatively additional hardwood blocking may be used at the pivot location positions to provide for improved fixing of the load bearing elements.

Pilot holes should be drilled to receive screw fixings. Min. 1 1/2 in. No.8 fully threaded 'Twinfast' or course threaded chipboard screws should be used for fixing.

NOTE: Bottom strap fittings can be over recessed to provide for required under door clearances.

WARNING: The pivot centre for these fittings extends a considerable distance from the opening face of the door. This can give rise to operational problems when used with narrow or thick door. See 'Growth Formula' Section 8 - Doorset Coordination

Fire Door Applications - Securing devices - Locks & Latches:

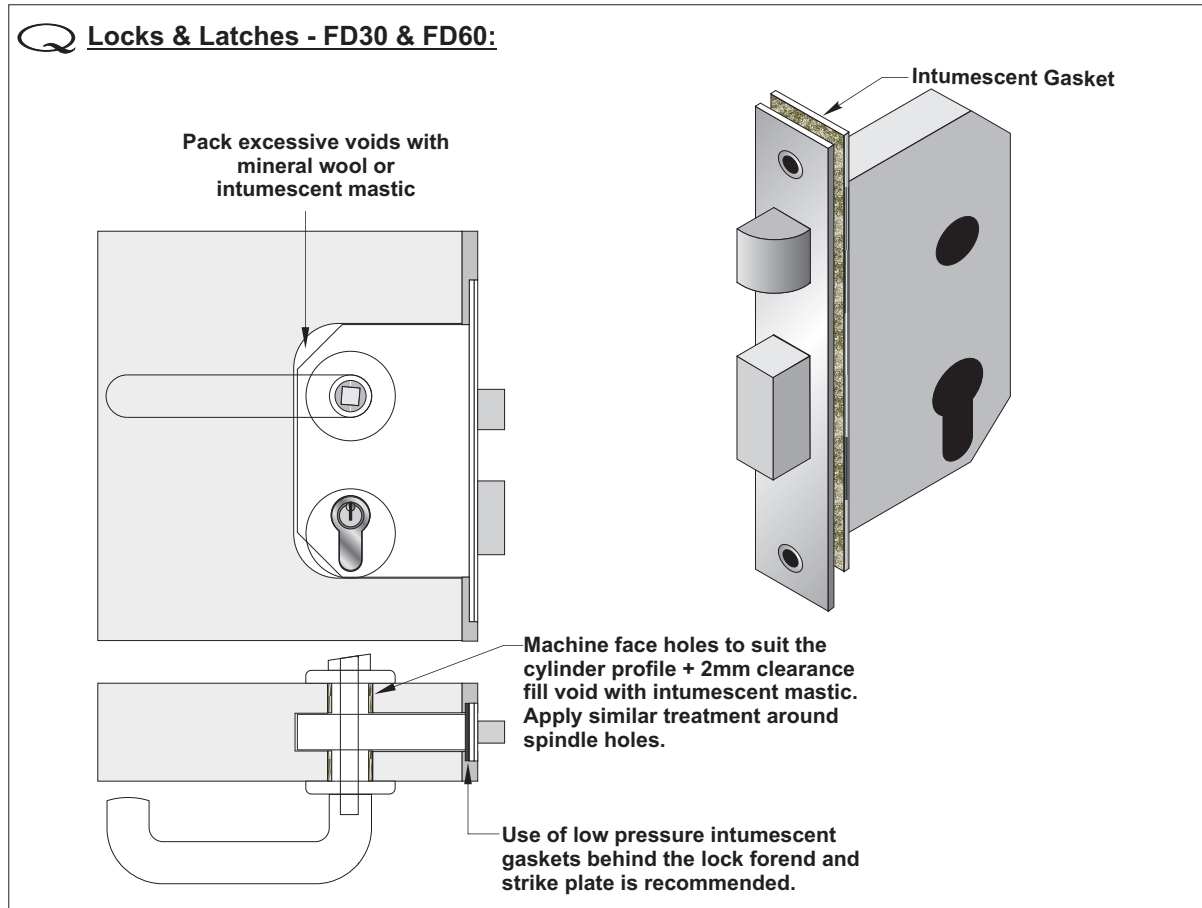

Locks & Latches - FD30 & FD60:

Latches and locks must be either as tested, alternatively components with the following specifications are acceptable:

Lock / Latch Specification FD30:

Maximum forend & strike plate dimension.	235mm high by 28mm wide by 4mm thick
Maximum body dimensions	25mm thick by 100mm wide by 150mm high
Intumescent Protection	1mm Interdens - Dufalite Developments Ltd.
	1mm MAP paper - Lorient Polyproducts Ltd.
<i>Under forend & keep plate for double doorsets (pairs) only.</i>	1mm Pyrostrip 300 - Mann McGowan Fabrications Ltd.
	1mm Therm-A-Strip - Intumescant Seals Ltd.
Materials	All parts essential to the locking / latching action (including the latch bolt, forend and strike) to be steel or brass.

Lock / Latch Specification FD60:

Maximum forend & strike plate dimension.	200mm high by 28mm wide by 4mm thick
Maximum body dimensions	25mm thick by 100mm wide by 165mm high
Intumescent Protection	1mm Interdens - Dufalite Developments Ltd.
	1mm MAP paper - Lorient Polyproducts Ltd.
<i>Under forend & keep plate for double doorsets (pairs) only.</i>	1mm Pyrostrip 300 - Mann McGowan Fabrications Ltd.
	1mm Therm-A-Strip - Intumescant Seals Ltd.
Materials	All parts essential to the locking / latching action (including the latch bolt, forend and strike) to be steel or brass.

Fire Door Applications - Securing devices - Flush Bolts:

Flush Bolts - FD30 & FD60:

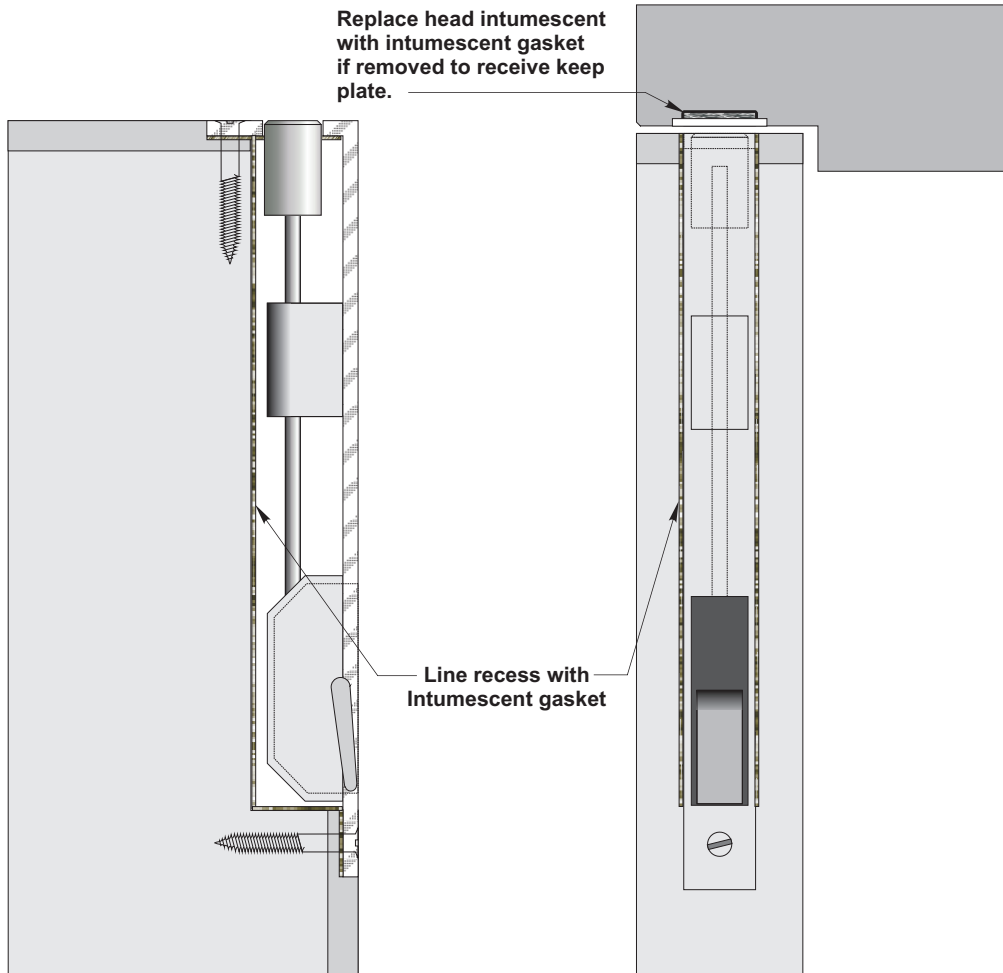

Flush Bolts FD30 & FD60:

Bolts may be required to secure the secondary leaf of pairs. There are no restrictions on the use of surface mounted bolts (e.g. Barrel bolts) that do not interfere with the edge sealing of the doors.

Edge fixed flush bolts are approved for FD30 and FD60 fire door applications subject to the following:

Flush Bolt Specification FD30:

Flush bolts may be incorporated into the top and bottom of the meeting edge of the inactive (or secondary) leaf of a double leaf doorset (pair), provided that the following maximum dimensions are not exceeded:

Length = 200mm.

Depth = 20mm.

Width = 20mm.

Flush bolts may be in steel or brass.

Flush Bolt Specification FD60:

Flush bolts may be incorporated into the top and bottom of the meeting edge of the inactive (or secondary) leaf of a double leaf doorset (pair), provided that the following maximum dimensions are not exceeded:

Length = 200mm.

Depth = 20mm.

Width = 20mm.

Flush bolts must be in steel.

For both FD30 and FD60 applications the mortice to receive flush bolts should be as tight to the mechanism as is compatible with its operation and the mortice must be lined with an intumescent gasket using:

2mm Interdens - Dufalite Developments Ltd. *OR*

2mm MAP paper - Lorient Polyproducts Ltd. *OR*

2mm Therm-A-Strip - Intumescent Seals Ltd. *OR*

2mm Pyrostrip 300 - Mann McGowan Fabrications Ltd.

Fire Door Applications - Other Hardware:

Operating Devices - Automatic Closing - FD30 & FD60:

Automatic closing devices e.g. Single Action Overhead Closers, must either be tested or components of equal specification that can demonstrate contribution to the required performance of these types of FD30 or FD60 doorset designs when tested to BS476 Pt.22 : 1987 or, BS EN 1634-1 : 2000.

It is recommended that these are used with min. 50mm thickness doors to minimise the risk of 'telegraphing' of the mortise on the face of the door and a risk of mechanical failures at the mortise position.

It is further recommended that doors are hardwood lipped on the top edge to provide for improved fixing.

NOTE: Concealed Closers:
Some concealed closer designs have been successfully tested for fire door applications in wood doors and may be used with Strebord[®] core doors in reliance upon that test data. However, these do require the removal of a large amount of core material to house the closer and its dedicated intumescent pack leaving minimal thickness door material either side of the mortise.

Concealed Closers:

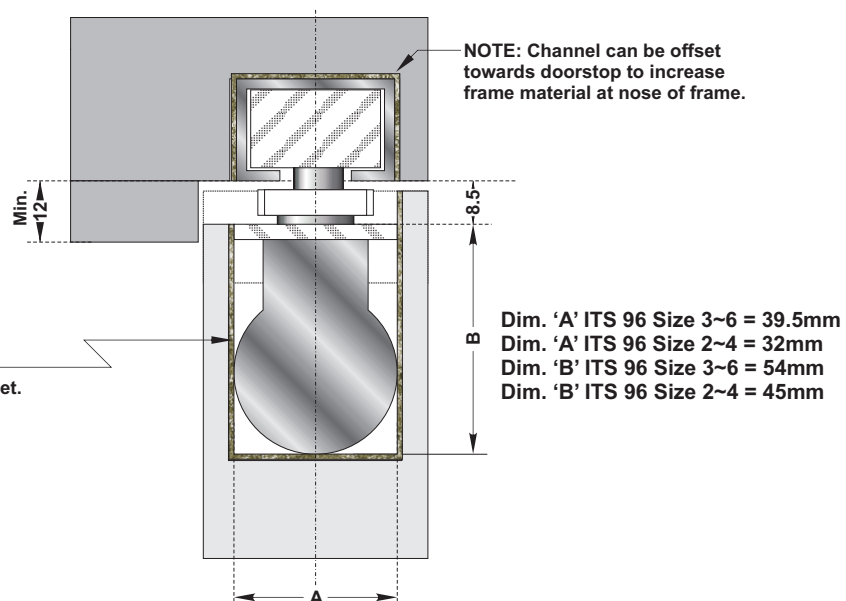
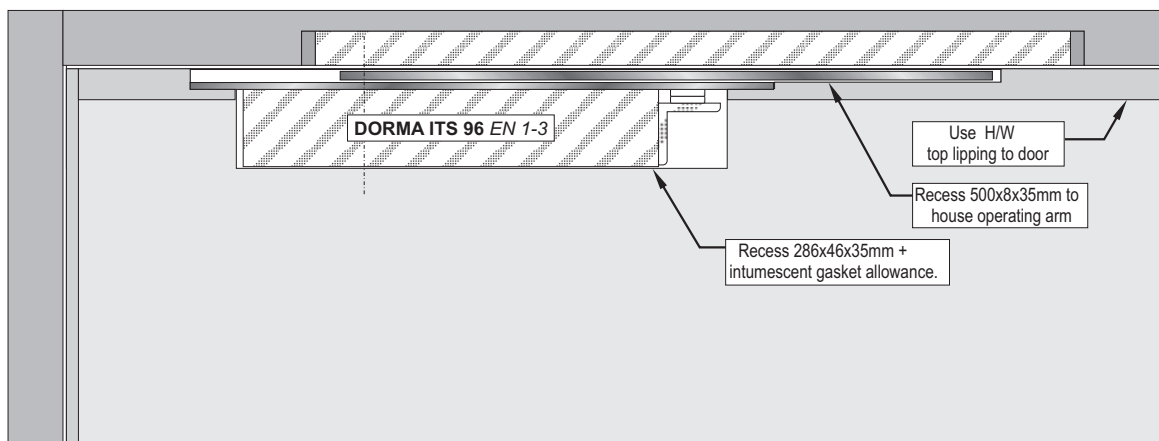

Fire Door Applications - Other Hardware:
Operating Devices - Pull Handles - FD30 & FD60:

Pull handles may be surface fixed to both FD30 & FD60 door provided that they are steel or brass and the length is limited to 1200mm between the fixing points.

Bolt through fixing pull handles up to the same length may also be used for fire door applications with no additional intumescent sealing required, provided that the hole through the door to receive the bolt provides for a tight fit.

Operating Devices - Push, Buffer and Kick Plates - FD30 & FD60:

Face fixed push, buffer and kick plates may be fitted to Strebord® doors for fire door applications provided that their fitting does not require the removal of any part of the door core.

These items of hardware are permitted up to a maximum of 20% of the door leaf area when screw fixed or 30% of the door leaf area when fixed with a contact adhesive.

For FD30 applications only, kick plates of maximum 2mm thickness may be recessed flush with the face of the core up to a maximum of 250mm high and fitted on either or both sides at the bottom of each leaf.

Operating Devices - Door Selectors - FD30 & FD60:

Door selectors may be freely applied for use with Strebord® doors for FD30 and FD60 fire door applications, provided that they are not invasive in the door leaf edges or the door frame. Those that are invasive will require fire resistance test / assessment evidence to support their use. Additional intumescent protection is not required unless fire test / assessment documentation relating to the particular device requires otherwise.

Operating Devices - Panic Hardware - FD30 & FD60:

Panic hardware may be used with Strebord® doors for FD30 and FD60 fire door applications, provided that the installation does not require the removal of any core material from the door leaf or the removal of any timber from the door leaf, doorstop or frame reveal. Further, the panic hardware should not, in any way, interfere with the self-closing action of the fire doors.

Miscellaneous Devices - Door Security Viewers - FD30 & FD60:

Door security viewers may be used with Strebord® core doors for FD30 and FD60 applications provided that the viewers are manufactured from brass or steel with viewer bodies of a diameter of 15mm (or less) and provided that the through-hole is bored tight to the case of the viewer with a maximum tolerance of +1mm. Lenses must be glass.

Viewers must be bedded in intumescent mastic unless otherwise approved for use without additional intumescent by reference to fire test / assessment data relating to the particular viewer design when tested in wood doors.

Miscellaneous Devices - Acoustic, Weather and Dust Perimeter Seals - FD30 & FD60:

Acoustic, weather and dust seals with a proven flame retardant performance may be fitted to Strebord® based doorsets for FD30 and FD60 applications providing that the fitting of the seals does not interfere with the activation of the doorset intumescent seals or hinder the self closing function of the door leaves.

Miscellaneous Devices - Automatic Threshold Seals - FD30 & FD60:

Fully mortised automatic threshold drop seals may be fitted to Strebord® based doorsets for FD30 and FD60 applications provided that the body of the automatic drop seal does not exceed 35mm high x 15mm wide (*excluding fixing flanges*). The body of the automatic drop seal should be in metal, aluminium or steel and the device is to be mortised centre thickness of the door.

Alternatively, surface mounted automatic drop seals may be used where the fitting of these does not require the removal of any core material.

Fire Door Applications - Other Hardware:

Miscellaneous Devices - Air Transfer Grilles - FD30 & FD60:

Air transfer grilles may be fitted to Strebord[®] based doorsets for FD30 and FD60 applications provided that the particular grille design is supported by fire test evidence to BS476 Pt.22 : 1987 or BS EN 1634-1 : 2000 that demonstrates an integrity performance that is at least equal to the desired fire performance of the doorset when installed in a wood door leaves of a compatible thickness.

Margins for apertures to receive grilles are to be as described for glazing (See Section 6) with the grille located towards the bottom of the door (*i.e. in the low / negative pressure area of the door under test conditions*) unless the fire test / assessment data relating to the particular grille provides for alternative locations in a wood based door.

The area of door occupied by the grille must not exceed 0.2m².

NOTE: When used with glazed doors, the maximum permitted area for glazing approved for the particular fire performance should be reduced by an amount that is at least equal to the area of the door that is occupied by the grille.

Miscellaneous Devices - Letter Plates / Boxes - FD30 & FD60:

Letter plates (boxes) may be fitted to Strebord[®] based doorsets for FD30 and FD60 applications provided that the particular letter plate (box) design is supported by fire test evidence to BS476 Pt.22 : 1987 or BS EN 1634-1 : 2000 that demonstrates an integrity performance that is at least equal to the desired fire performance of the doorset when installed in a wood integrity leaves of a compatible thickness.

Margins to the leaf edges must not be less than the margins approved for glazing (See Section 6 - Glazing).

Letter plates (boxes) should be located towards the bottom of the door (*i.e. in the low / negative pressure area of the door under test conditions*) unless the fire test / assessment data relating to the particular letter plate (box) provides for alternative locations in a wood based door.

Miscellaneous Devices - Cable Ways for electric locks / strike plates - FD30 & FD60:

Cable ways to provide for a route for the connection of electric locks / strikes with command units are permitted for use with Strebord[®] core doors subject to the following:

The particular locking devices should comply with the approved latch / lock specifications for use with Strebord[®] door for fire rated applications as described by reference to page 9.5.

The cable-way may be concealed in one of the following ways:

FD30: An 8mm dia. (max.) diameter hole drilled centrally in the door thickness and horizontally across the width of the door.

FD30 and FD60: An 8x8mm groove positioned centrally in the door thickness to be applied to the door core, before the application of lippings. The groove to be positioned below (and not exceeding mid door leaf height) at the hanging edge passing around the bottom of the leaf and returning to the lock / strike position at the closing stile of the door. The cable-way groove to be fitted with an intumescent gasket using:

- 2mm Interdens - Dufalite Developments Ltd. OR
- 2mm MAP paper - Lorient Polyproducts Ltd. OR
- 2mm Therm-A-Strip - Intumentent Seals Ltd. OR
- 2mm Pyrostrip 300 - Mann McGowan Fabrications Ltd.

WARNING: The use of hardware items with a proven fire performance when used with metal doors should not be used with wood based fire doors (and vice versa) without the benefit of further testing.