



Strebord[®]

Door Core Technical Manual

Strebord 44 FD30
Strebord 54 FD60

AL1
January 2012

STREBORD TECHNICAL MANUAL v8 - Amendment AL1 - January 2012

The following amendments provide for updates to the Strebord Technical Manual v8 to correct for previous errors and to incorporate new information following further development of the Strebord product.

This amendment is published by reference to the Falcon Panel Product Ltd. web site. Holders of hard copy manuals may print pages marked 'AL1' above the page number reference and replace existing manual pages accordingly.

Amendment List 1 - January 2012:

Section 2: Fire Door Applications: Amendment to text on page 2.26:

Replace: Existing page 2.26 with new page 2.26AL1

Deleted: 'Lorient 100' in bottom left box.

Inserted: 'Lorient 617' in bottom left box.

Section 4: Intumescent Seals: Amendment to text on page 4.94:

Replace: Existing page 4.94 with new page 4.94AL1

Deleted: '2No. 15x4 Therm-A-Glaze' to 'Q' Mark note under intumescent type box' in bottom left box.

Inserted: '2No. 15x4 Lorient 617' to 'Q' Mark note under intumescent type box' in bottom left box.

Section 6: Glass & Glazing: Amendment to page 6.12:

Replace: Existing page 6.12 with new page 6.12AL1

Add: Mann McGowan Pyroglaze 60 with 0.72m² application area.

Amend: Application area for Pyroplex System FG60 from 0.72m² to 0.25m².

Section 9: Hardware: Amendment to page 9.2:

This amendment is introduced to provide for clarification with regard to the use of intumescent gaskets with hinges for FD30 and FD60 fire door applications.

Replace: Existing page 9.2 with new page 9.2AL1

Section 10a: Acoustic Assessments: Complete section:

This section has been amended to illustrate seal types referred to in the assessment lists and to introduce the new Norsound WAVE combined kick plate / automatic door bottom with some amendments to assessed configurations.

Remove: Existing Section 10a.

Insert: New Section 10aAL1.

Section 13: Panelled Doors: Amendments to pages 13.1, 13.2 & 13.4:

This amendment is introduced following more recent testing and now provides for a single panel door for NFR (non fire rated) and FD30 fire door applications.

Remove : Pages 13.1, 13.2 & 13.4.

Insert: New pages 13.1AL1, 13.2AL1 & 13.4AL1 showing the new single panel design.

Published January 2012 by:

Falcon Panel Products Ltd.,
Clock House,
Station Approach,
Shepperton,
Middlesex TW17 8AN
Tel: +44 (0) 1932 256580
Fax: +44 (0) 1932 230268

UNLATCHED DOORSETS

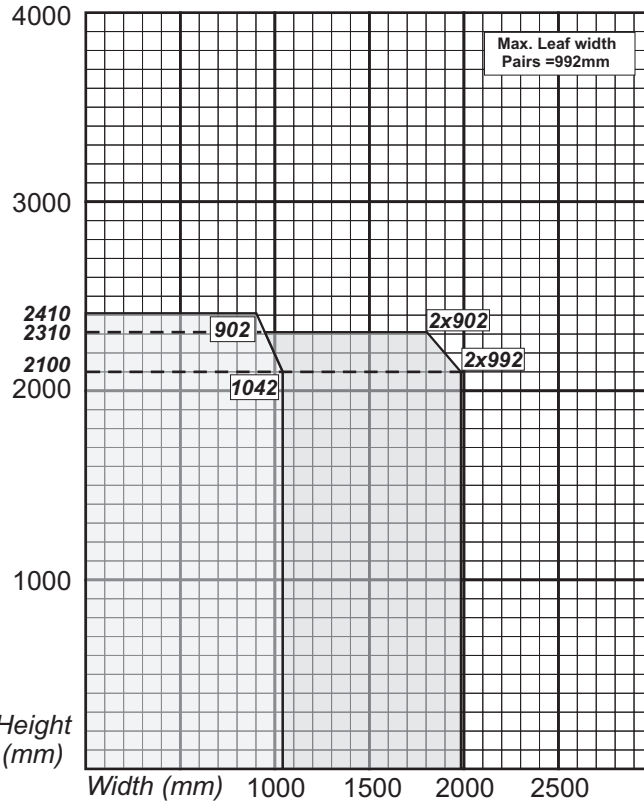
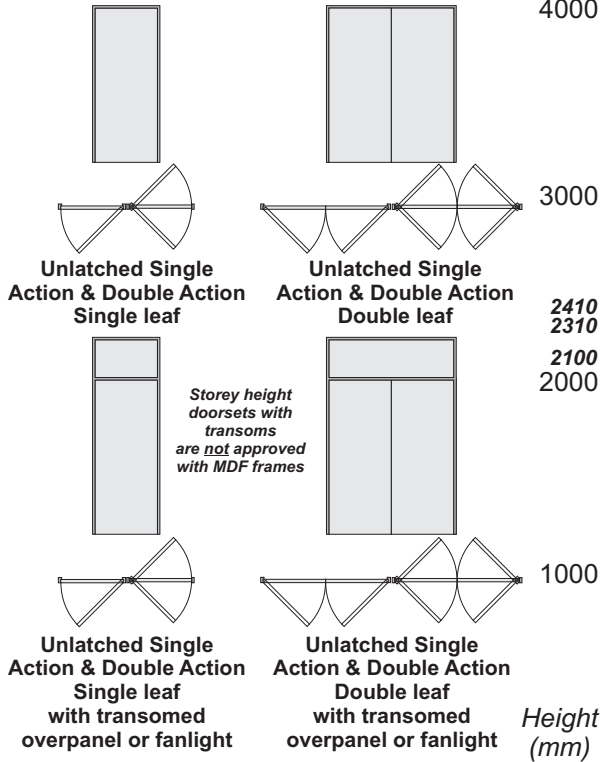

Configuration		Height (mm)	Width (mm)
Unlatched Single Action Single Door (ULSASD)	From	2100	1042
	To	2410	902
Double Action Single Door (DASD)	From	2100	1042
	To	2410	902
Unlatched Single Action Double Door (ULSADD)	From	2100	992
	To	2310	902
Double Action Double Door (DADD)	From	2100	992
	To	2310	902

Maximum Glazed Area See Section 6:	Single door doorset Double door doorset	1.9m ²	Maximum Overpanel height	Single door doorset Double door doorset	2000mm 1500mm
---------------------------------------	--------------------------------------------	-------------------	--------------------------	--------------------------------------------	------------------

Frame Specification See Section 7	Single door doorset Double door doorset <i>NOTE: Storey height doorsets with transoms are not approved with MDF frames.</i>	450kg/m ³ Softwood or Hardwood OR 700kg/m ³ MDF
--------------------------------------	-----------------------------------------------------------------------------------------------------------------------------------	-----------------------------------------------------------------------------

<p>Intumescent Seals 10x4mm PVC encapsulated Lorient 617</p> <p>See Section 4 - Intumescent Seals and Section 9 - Hardware for further information</p>	<p>Head: 10x4mm exposed and fitted centrally in the leaf or frame head. Jams & Overpanel: 10x4mm exposed and centrally fitted to leaf or frame. Meeting edges: Square: 2No. 10x4mm spaced 12mm apart and centrally fitted in one leaf. Rebated: Not approved.</p>
-------------------------------------------------------------------------------------------------------------------------------------------------------------------	--------------------------------------------------------------------------------------------------------------------------------------------------------------------------------------------------------------------------------------------------------------------------------------------------------------------------

Strebond^{®54} *Door Core* **Hardwood Door Frames**

FD60

Intumescent Seals

2x15x4mm Lorient 617

Q Double Leaf FD60 applications using 2No. 15x4mm Lorient 617 Intumescent Seals.

NOTE: See Section 7 - Doorframes for 'Q' Mark approved minimum frame section dimensions for fire door applications.



Double leaf Door Height Doorsets

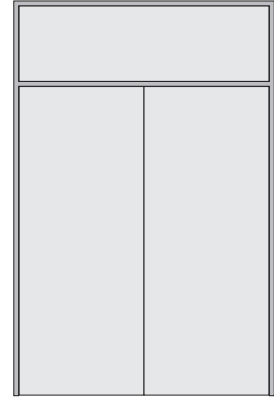

Double leaf Storey Height Doorsets with Transom

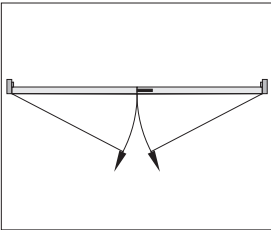

Latched Double leaf Single Action Doorsets (Pairs):

Jambs & Head = 2x15x4mm PVC encased Lorient 617.

Meeting Stiles = 2x15x4mm PVC encased Lorient 617.

Door Leaf sizes: From: 2120 x 2x926mm
To: 2300 x 2x915mm

NOTE 1: For storey height doorsets use 2x15x4mm PVC encased Lorient 617 to all sides of the overpanel.

NOTE 2: Rebated Meeting stiles are not 'Q' Mark approved for this application.

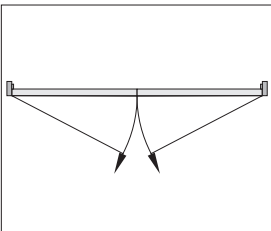

Unlatched Double leaf Single Action Doorsets (Pairs):

Jambs & Head = 2x15x4mm PVC encased Lorient 617.

Meeting Stiles = 2x15x4mm PVC encased Lorient 617.

Door Leaf sizes: From: 2120 x 2x926mm
To: 2255 x 2x915mm

NOTE 1: For storey height doorsets use 2x15x4mm PVC encased Lorient 617 to all sides of the overpanel.

NOTE 2: Rebated Meeting stiles are not 'Q' Mark approved for this application.

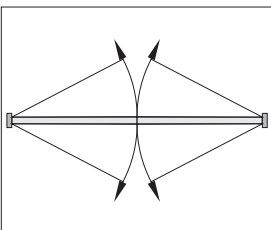

Double Action Double leaf Doorsets (Pairs):

Jambs & Head = 2x15x4mm PVC encased Lorient 617.

Meeting Stiles = 2x15x4mm PVC encased Lorient 617.

Door Leaf sizes: From: 2120 x 2x926mm
To: 2255 x 2x915mm

NOTE 1: For storey height doorsets use 2x15x4mm PVC encased Lorient 617 to all sides of the overpanel.

Strebord^{©54}

Door Core

Glass & Glazing FD60

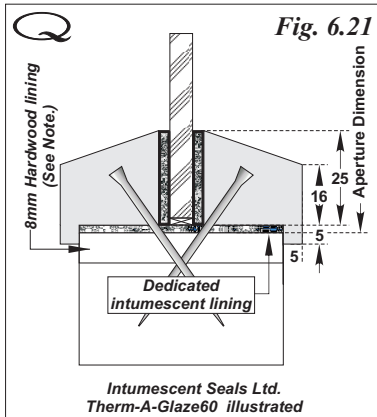

Intumescent Seals Ltd. - *Therm-A-Glaze 60*

Sealmaster Ltd. - *Fireglaze Mastic*

Pyroplex - *Pyroplex System FG60*

Mann McGowan Ltd. - *Pyroglaze 60*

- These systems must be used with its dedicated intumescent lining to the aperture (*Refer to manufacturers details*).

- Bead to be fixed using 60mm long x 2mm dia. steel pins OR 60mm long No.8 screws inserted at 35~40° to the vertical at no more than 50mm from each corner and at 150mm maximum centres.

Maximum approved glazed area - Therm-A-Glaze 60 = 0.72m²

Maximum approved glazed area - Fireglaze Mastic = 0.72m²

Maximum approved glazed area - Pyroglaze 60 = 0.72m²

Maximum approved glazed area - System FG60 = 0.25m²

NOTE: Min. 640kg/m³ 8mm Hardwood lining must be used with Pyroplex System FG60 - Recommended option for other beading systems

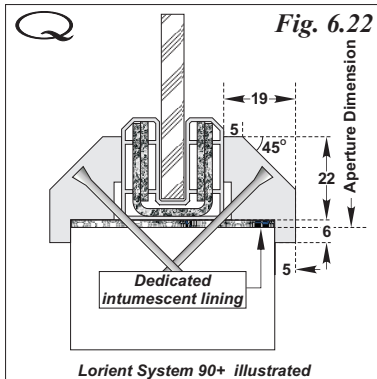

Lorient Polyproducts Ltd. - '*System 90 PLUS*'

- This system must be used with its dedicated intumescent lining to the aperture (*Refer to manufacturers details*).

- Bead to be fixed using 60mm long x 2mm dia. steel pins OR 60mm long No.8 screws inserted at 45° to the vertical bead at no more than 50mm from each corner and at 150mm maximum centres.

Maximum approved glazed area - System 90 PLUS = 0.72m²

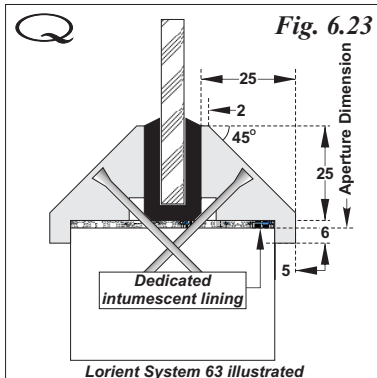

Lorient Polyproducts Ltd. - '*System 63*' Flexible Gasket

- This system must be used with its dedicated intumescent lining to the aperture (*Refer to manufacturers details*).

- Bead to be fixed using 60mm long x 2mm dia. steel pins OR 60mm long No.8 screws inserted at 45° to the vertical bead at no more than 50mm from each corner and at 150mm maximum centres.

Maximum approved glazed area - System 63 = 0.72m²

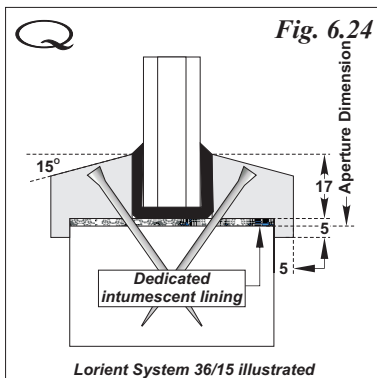

Lorient Polyproducts Ltd. - '*System 36/15*' Flexible Gasket

- This system must be used with its dedicated intumescent lining to the aperture (*Refer to manufacturers details*).

- Bead to be fixed using 60mm long x 2mm dia. steel pins OR 60mm long No.8 screws inserted at 35~40° to the vertical bead at no more than 50mm from each corner and at 150mm maximum centres.

Maximum approved glazed area - System 36/15 = 0.72m²

Strebord[®]
Door Core
Hardware

Fire Door Applications - Hanging devices - Hinges:

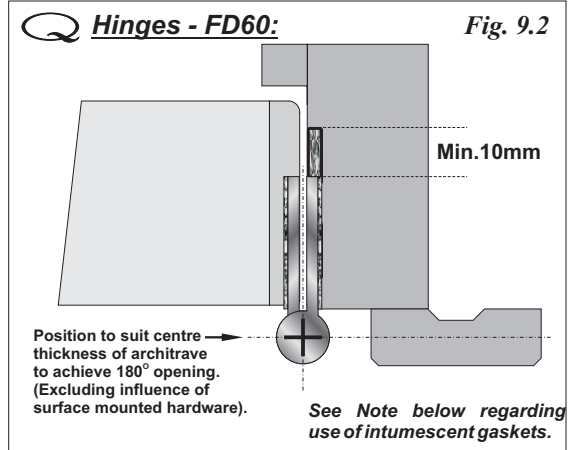
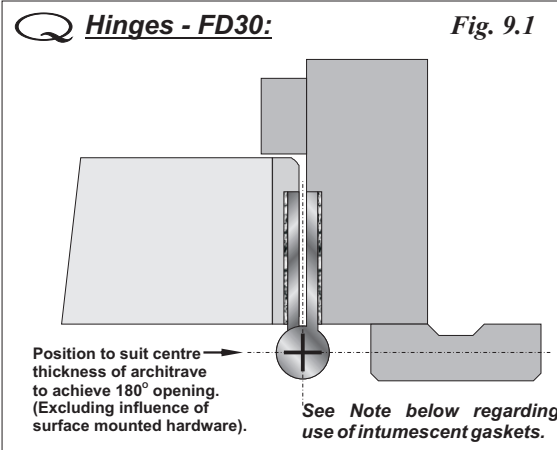

Hinge Specification FD30:

Blade Height	90~120mm
Blade Width (excluding knuckle)	32~35mm
Blade Thickness	2.5 ~ 4mm
Fixings	Min. 4No. 38mm long fully threaded 'twinfast' or chipboard screws per hinge blade.
Materials	Brass (800°C melting point). steel or stainless steel
Intumescent Protection	1mm Interdens - Dufalite Developments Ltd. 1mm MAP paper - Lorient Polyproducts Ltd. 1mm Pyrostrip 300 - Mann McGowan Fabrications Ltd. 1mm Therm-A-Strip - Intumescent Seals Ltd.
NOTE:	Intumescent gaskets are not required for use under hinge blades for door leaf heights less than 2670mm.
Hinge Positions: Leaf dimensions <2400mm	Top = 150 ~ 180mm from top of door. Centre: Min. 200mm from top hinge to central between top & bottom hinge. Bottom: 180 ~ 250mm from bottom of door.
Hinge Positions: Leaf dimensions >2400mm	Top = 150 ~ 180mm from top of door. Centre Hinges: 2No. Equispaced between top and bottom hinges Bottom: 180 ~ 250mm from bottom of door.

Hinge Specification FD60:

Blade Height	90~120mm
Blade Width (excluding knuckle)	30~35mm
Blade Thickness	2.5 ~ 4mm
Fixings	Min. 4No. 38mm long fully threaded 'twinfast' or chipboard screws per hinge blade.
Materials	Steel or stainless steel
Intumescent Protection	1mm Interdens - Dufalite Developments Ltd. 1mm MAP paper - Lorient Polyproducts Ltd. 1mm Pyrostrip 300 - Mann McGowan Fabrications Ltd. 1mm Therm-A-Strip - Intumescent Seals Ltd.
NOTE:	For door leaf heights less than 2285mm, intumescent gaskets are not required for use under hinge blades provided that the hinge design permits a minimum of 10mm of intumescent seal to run uninterrupted past the hinge blade.
Hinge Positions: Leaf dimensions <2400mm	Top = 150 ~ 180mm from top of door. Centre: Min. 200mm from top hinge to central between top & bottom hinge. Bottom: 180 ~ 250mm from bottom of door.
Hinge Positions: Leaf dimensions >2400mm	Top = 150 ~ 180mm from top of door. Centre Hinges: 2No. Equispaced between top and bottom hinges Bottom: 180 ~ 250mm from bottom of door.

In addition, the hinges should provide for the appropriate BS EN 1935 : 2002 performance according to the door weight and anticipated usage.

The hinge knuckle centre should be set as near to the door face as possible to minimise the 'door growth' during operation. (See 'Growth Formula' - Section 8 - page 8.32 - Coordination).

A hinge knuckle centre at the centre line of the architrave thickness will allow for 180° opening (excluding the influence of other surface mounted hardware).

Pilot holes should be drilled to receive hinge fixing screws with hinges fixed to the door leaf using Min. 1 1/2in. No.8 fully threaded 'Twinfast' or course threaded chipboard screws.

