

Global Fire Resistance Assessment

Sponsor:

Pacific Rim Wood UK Ltd.
Unit 3, Kingdom Fields
Bratton Fleming
Barnstaple
EX31 4EN

CONFIDENTIAL

Report: Chilt/A02141 Revision I

Contract: CNA/F14089

Global Fire Resistance Assessment of Flamebreak Doorsets for
60 Minutes Fire Resistance

Valid From: 22nd April 2014

Valid Until: 22nd April 2019

Page 1 of 58

This document is confidential and remains the property of Chiltern International Fire Ltd. The legal validity of this report can only be claimed on the presentation of the complete report.



BM TRADA – the new name for Chiltern International Fire Ltd.

From July 1st 2013, Chiltern International Fire Ltd. commenced trading under the name of its parent company BM TRADA and at the same time adopted a brand new visual identity.

Historically, the group has delivered its services through a number of individual companies: BM TRADA Certification Ltd, TRADA Technology Ltd, Chiltern International Fire Ltd. (including Chiltern Dynamics) and a network of international offices. Both BM TRADA Group and these individual companies will now trade under the same name - BM TRADA - and adopt the new visual identity.

To coincide with this change, our Technical Reports, Test Reports, Products Assessments, company stationery and marketing collateral have been re-designed to carry the new branding and visual identity.

The validity of all documents previously issued by the individual companies including certificates, test reports and product assessments is unaffected by this change and a letter to this effect will be available to download from our website www.bmtradagroup.com.

About BM TRADA

With origins dating back to 1934, we have a deep history and services which are highly valued by our customers. We offer independent certification, testing, inspection, training and technical services around the world. In all these areas we continue to use industry-leading experts in their chosen fields to develop and deliver services – an ethos that has been at the heart of our approach since we began.

A recent review of our businesses and customers revealed that the individual identities sometimes make communications confusing, and that in an already complex business area, clarity and simplicity in communications is rare, but valued. It also revealed that a single identity and combined offer would help us strengthen our appeal.

With this in mind, we brought the companies together under the name BM TRADA and took the opportunity to create a fresh new visual identity.

We have modernised our image and combined our strengths. However, our values, our people and the integrity of our services remain the same. I hope you will welcome these changes and the improvements they will bring.



Jon Osborn
Chief Operating Officer

Contents

	Page No.
1 Introduction.....	4
2 General Description of Construction	4
3 Leaf Sizes.....	4
4 Configurations	5
5 Leaf Size Adjustment.....	5
6 Overpanels, Fanlights & Side Screens	5
7 Glazing	15
8 Door Frames	25
9 Edging Materials.....	27
10 Leaf Facing Materials	30
11 Intumescent Materials	31
12 Adhesives.....	31
13 Tested Hardware	32
14 Additional & Alternative Hardware	32
15 Door Gaps.....	37
16 Structural Opening.....	37
17 Fixings.....	38
18 Sealing to Structural Opening	39
19 Insulation.....	40
20 Smoke Control.....	40
21 Conclusion.....	41
22 Declaration by the Applicant	42
23 Limitations	43
24 Validity.....	43
Appendix A - Performance Data	44
Appendix B - Proprietary 60 Minute Glazing Systems	46
Appendix C - Revisions & Amendments.....	48
Appendix D - Data Sheets	49

The legal validity of this report can only be claimed on presentation of the complete report.

1 Introduction

This document constitutes a global assessment to collate the fire resistance test evidence for Pacific Rim Wood Ltd. Flamebreak 60 minute fire resisting doorsets, a construction manufactured by P.T. Kutai Timber of Indonesia. The assessment uses established extrapolation and interpretation techniques in order to extend the scope of application. It does this by determining the limits for the design, based on the tested constructions and performances obtained. The assessment is an evaluation of the potential fire resistance performance, if the elements were to be tested in accordance with BS 476: Part 22: 1987.

2 General Description of Construction

The construction of Flamebreak 60 minute door leaves includes the following basic components in the design:

Element		Species/type	Configuration (all dims in mm)	Min. Density (kg/m ³)
Core – 3 layers	Outer layers	Parasorianthes falacateria or Albisia falcatta	Vertically orientated 13.5 thick x 45 wide lamels	180 - 360
	Inner layers	'Mixed tropical hardwood'	Horizontally orientated 15 thick x 28 wide lamels	480
Stiles		Agathis or 'mixed tropical hardwood' in 2 lamels	35 wide (total) x 42 thick, incorporating a 9 x 9 tongue located into the core material	Agathis – 480 'Mixed tropical hardwood' - 610
Top Rail		Agathis or 'mixed tropical hardwood' in 3 lamels	75 wide (total) x 42 thick, incorporating a 9 x 9 tongue located into the core material	Agathis – 480 'Mixed tropical hardwood' - 610
Bottom Rail		Agathis or 'mixed tropical hardwood' in 3 lamels	35 wide (total) x 42 thick, incorporating a 9 x 9 tongue located into the core material	Agathis – 480 'Mixed tropical hardwood' - 610
Facings		Various timber based products – see section 10 for details	6 thick	Various
Lippings – all edges		Hardwood	10 thick	640

The Flamebreak design is supplied with stiles and rails to the specification in the table above. The stiles and bottom rail may either remain in position or be removed for manufacturing since the testing has evaluated constructions with and without these elements. The top rail must remain in position.

3 Leaf Sizes

It can be seen from the list of fire resistance tests contained in appendix A, that the most demanding configuration of the tested design is the unlatched, single acting, double leaf doorset and therefore extrapolation is based primarily upon this test. The assessment for increased leaf dimensions is based on the margin of over performance of the design above 60 minutes integrity, and the characteristics exhibited during test.

Doorsets containing leaves with smaller dimensions than those stated are deemed to be less onerous and are therefore automatically covered.

4 Configurations

Based on the test evidence listed in appendix A, this assessment covers the following doorset configurations:

Abbreviation	Description
LSASD & ULSASD	Latched & unlatched, single acting, single doorset
DASD	Double acting, single doorset
LSADD & ULSADD	Latched & unlatched, single acting, double doorset
DADD	Double acting, double doorset

Unequal leaf double doorsets are covered by this assessment with no restriction on the smaller leaf dimension.

5 Leaf Size Adjustment

Flamebreak 60 door leaves may be altered as follows:

Element	Reduction
Leaf	Leaves may be reduced in height and width without restriction, but reduction in height must be from the bottom edge only. The top rail must be preserved at its manufactured dimensions
Lipping	The dimensions stated in section 9 may be reduced by 20% for fitting purposes

6 Overpanels, Fanlights & Side Screens

6.1 Overpanels

Overpanels of the same construction as the door leaves may be used with this doorset design only when fitted with a transom. The transom must be of the same section and material assessed for the door frames and the overpanel must be fully contained within the door frame (see following diagram).

Door frame joints must utilise one of the following four methods: mortise and tenon joints; half lapped joints; mitre joints; butt joints (see section 8.2).

All methods require joints to be tight, with no gaps, and require mechanical fixing with the appropriate size ring shank nails or screws. Butt joints must be additionally bonded with urea formaldehyde or equivalent.

Overpanels must be fixed by screwing through the rear of the frame with steel screws passing at least 30mm into the centre line of the overpanel. Fixings must be no more than 100mm from each corner and a maximum of 250mm centres in between.

The legal validity of this report can only be claimed on presentation of the complete report.

The intumescent seals specified for the jambs in appendix D must also be fitted to all edges of the overpanel. The seals may be fitted in the overpanel edges or alternatively in the frame reveal. Providing the intumescent seals are fitted on all edges of the overpanel, a 2mm gap tolerance is permitted between the overpanel and frame/transom.

It is permitted to include a glazed aperture within the overpanel providing the glazing is within the parameters given in section 7.

Maximum overpanel heights are as follows:

- Single doorsets - 2000mm
- Double doorsets - 1500mm

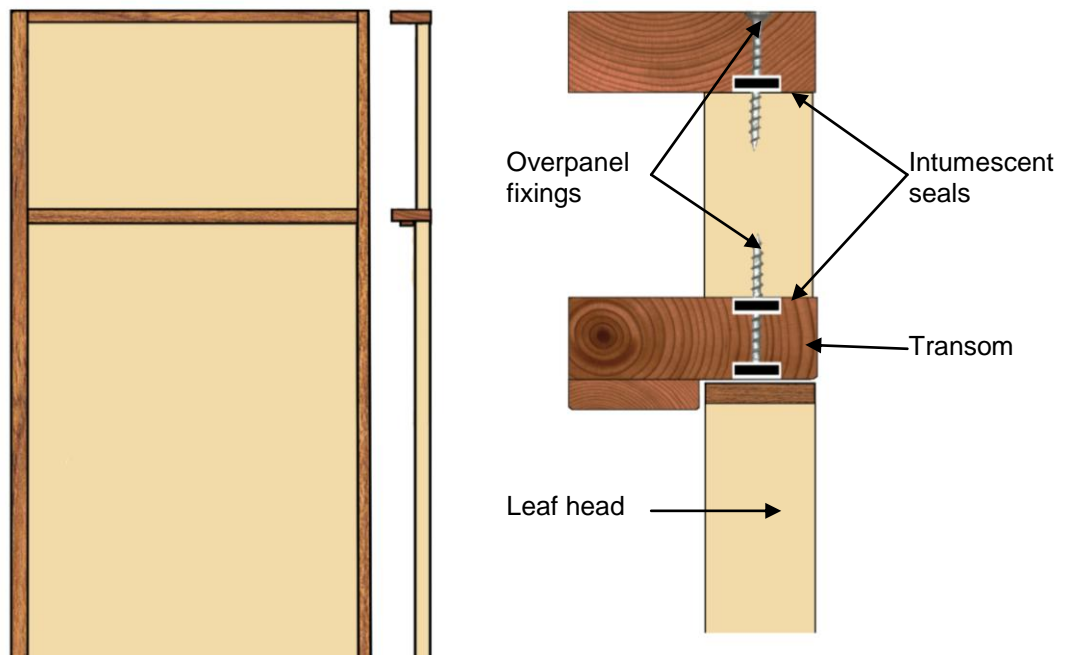

Note: Drawing is representative of doorset construction only; actual construction must be as the text within this document specifies.

6.2 Glazed Fanlights & Side Screens

6.2.1 General

It is our assessment that Flamebreak 60 doorsets may include glazed fanlights or side screens. The timber frame and glazing beads must be hardwood with a minimum density of 640kg/m³, whilst the frame section must be a minimum of 70mm x 44mm. Other details of the door frame and screen construction must comply with the specification contained in section 8.

The maximum assessed fanlight and side screen dimensions are detailed in the table below, subject to the following restriction:

- The glazing system and glass must be able to demonstrate adequate performance when tested as a window or screen in accordance with BS 476: Part 22: 1987 or BS EN 1634-1, at the pane dimensions to be installed.

Screen Element	Configuration	Height (mm)	Width (mm)
Fanlight	Single & double doorsets	≤600	Overall door width
Side Screen	Single & double doorsets	Overall door height	≤600

The legal validity of this report can only be claimed on presentation of the complete report.

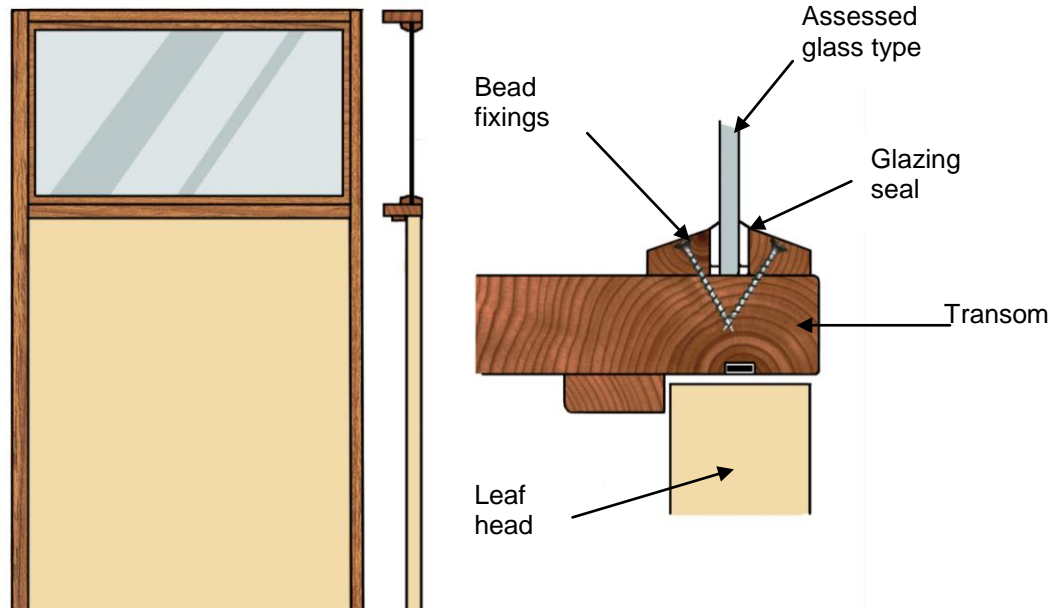

Note: Drawing is representative of doorset construction only; actual construction must be as the text within this document specifies.

6.2.2 Common Frame Sections – Glazed Screens

The following drawings depict possible constructions of common frame sections for the screens and door frame jambs:

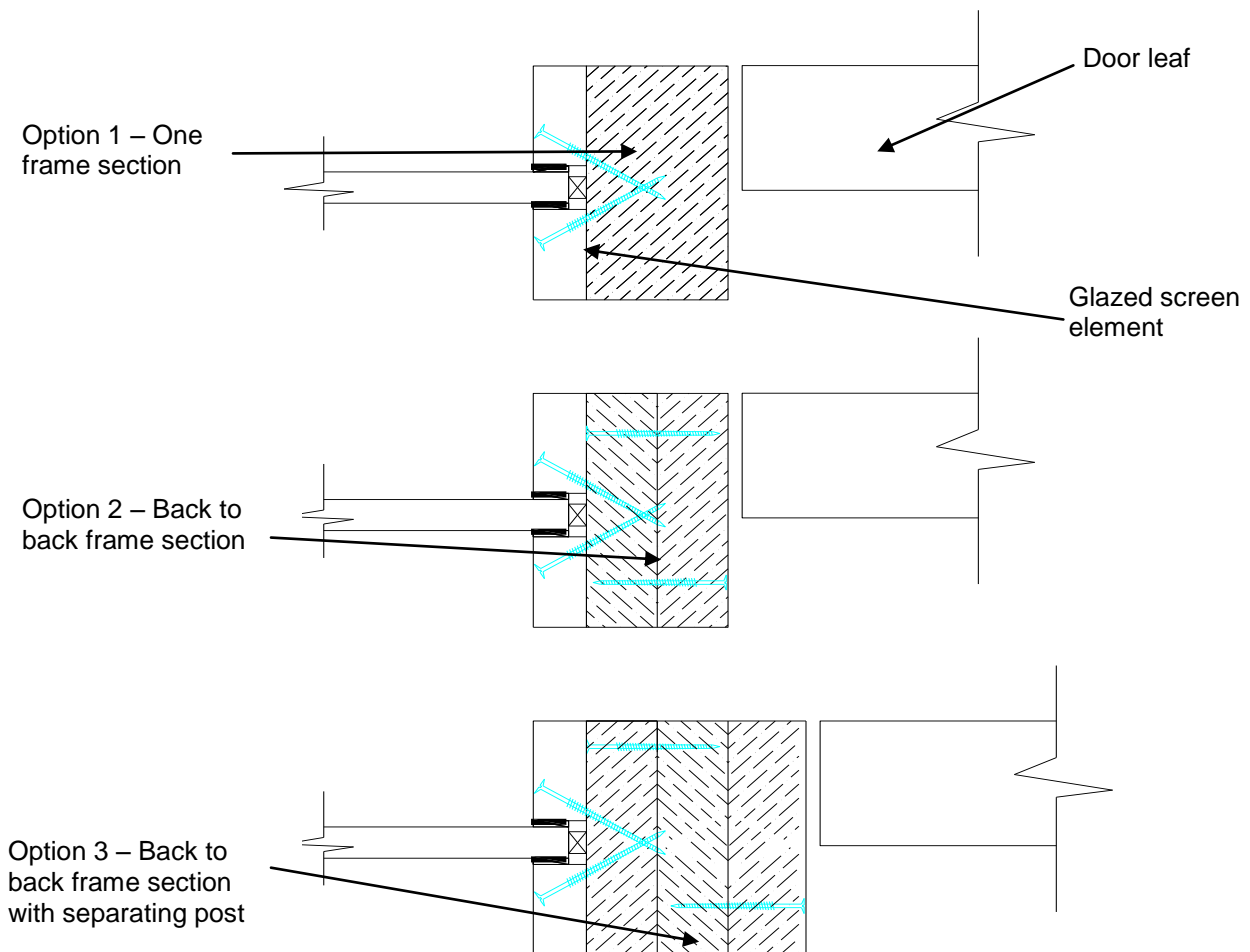

The legal validity of this report can only be claimed on presentation of the complete report.

When using separate sections of timber, as shown above (option 2 and 3), each section must be suitably fixed to one another using appropriate steel screw fixings and glued using one of the adhesives approved for the lipping in the adhesive section of this report. Screws must be fixed at 600mm centres and locate to approx 2/3 depth of the adjacent timber section. The overall frame section and material must match that given in this assessment for each glass type and glazing specification. Joints must be tight with no gaps.

It is permitted to include maximum 3mm (w) x 3mm (d) quirks at the junction of each timber section for option 2 and 3.

Drawing is representative of each type of common frame member, actual construction in terms of intumescent seal location and material, etc. must be as the text within this document specifies.

6.2.3 Screen Elevations

The following drawing depicts a possible door and glazed screen configuration. The diagram is for information only. All details to remain as specified herein.

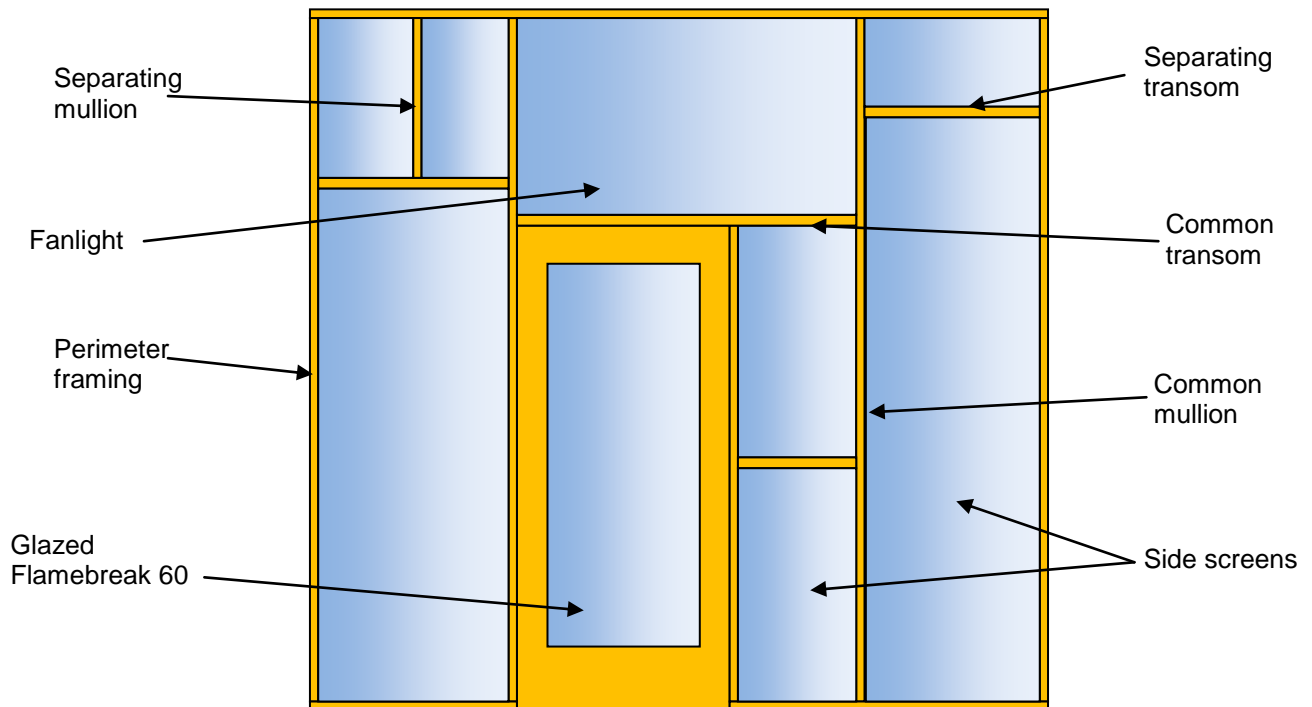

6.3 Specific Glass Types

The following sections provide a scope of approval for different glass types when used for glazing fanlights or side screens. Fanlights may be used in conjunction with side screens subject to the specification given for each of the glass types.

Unless stated in the following sections, all construction details for the doorset must remain as specified in the main assessment.

6.3.1 Pyrodur 60-10 (10mm thick) – Pilkington Group Ltd.

Transom/mullion details:

- Minimum 80mm deep x 44mm thick hardwood (minimum density 640kg/m³). This timber section can be used for both door jambs and transoms above doors included within screens and for the perimeter framing of the screen and the transoms and mullions separating individual panes of glass within the fanlights and side screens.

Glazing details:

- 20mm high x 20mm deep hardwood beads (minimum density 640kg/m³) with a 15° chamfer.
- 40mm long size 6 - 8 steel wood screws at maximum of 50mm from corners and 150mm centres inserted at 30° to the glass.
- 20mm x 2mm Interdens located between the glass and the beads.
- 3mm high x 6mm wide x 40mm long hardwood or non-combustible setting blocks fitted at 300mm centres along bottom edge of glass with 3mm expansion allowance to all edges.

Maximum single pane dimensions:

Screen Element	Height (mm)	Width (mm)
Fanlight	810	1670
Side Screen	2057	956

- The pane dimensions given above represent the maximum permitted width against maximum permitted height. Panes with smaller dimensions are acceptable.

Multiple panes:

- The fanlights and side screens may comprise multiple panes of glass providing the total doorset and screen assembly does not exceed 2950mm high and the transom/mullion restrictions above are complied with.

Leaf configurations and screen dimensions:

- The total width of the screen assembly is unlimited.
- The screen assembly may only contain 1No. single or double leaf doorset.

6.4 Norsound Vision Glazing Systems – Fanlights & Side Screens

6.4.1 General

Timber framed doorsets may include glazed fanlights and/or side screens.

The glazing system and beads must meet the specification shown in sections 6.4.4 – 6.4.6.

The door frame and screen framing construction must comply with the specification shown in section 6.4.7.

The maximum assessed fanlight and side screen dimensions are detailed in the table below, subject to the following restriction:

- The glass must be able to demonstrate adequate performance when tested as a window or screen in accordance with BS 476: Part 22: 1987 or BS EN 1634-1, at the pane dimensions to be installed.

Screen Element	Configuration	Height (mm)	Width (mm)
Fanlight	Single & double doorsets	≤600	Overall door width
Side Screen	Single & double doorsets	Overall door height	≤600

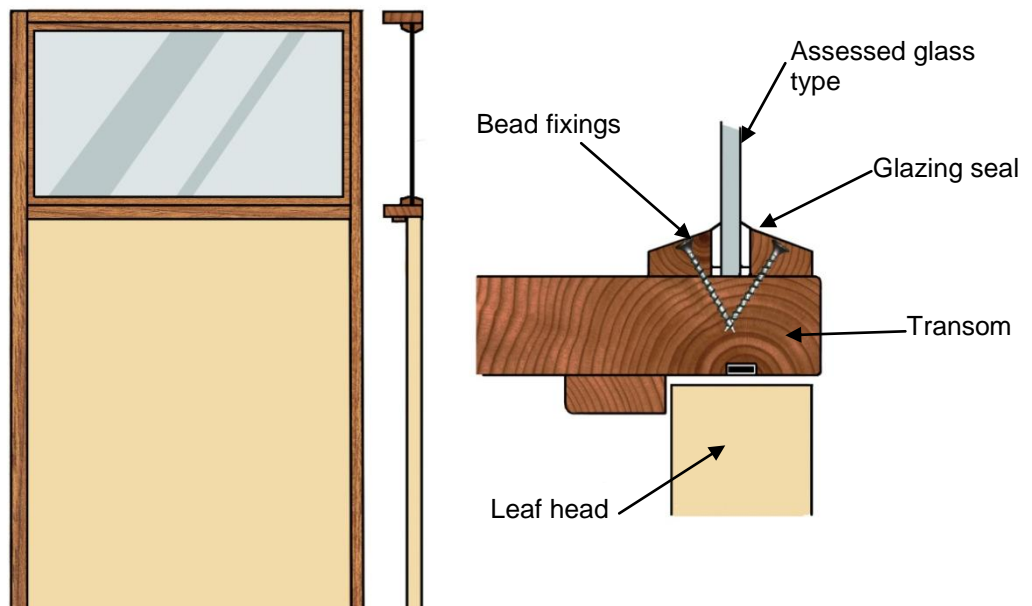

Note: Drawing is representative of doorset construction only; actual construction must be as the text within this document specifies.

6.4.2 Common Frame Sections – Norsound Vision Glazing System

The following drawings depict possible constructions of common frame sections for screens and door frame jambs:

Option 1 – One frame section

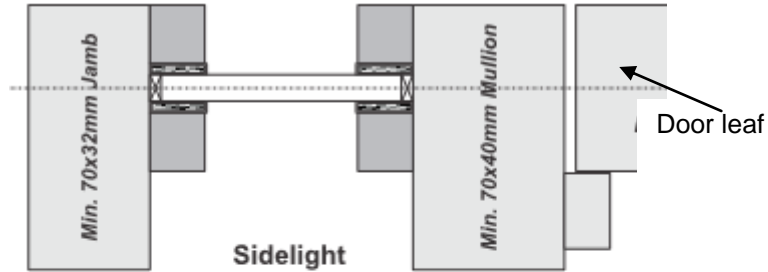

Option 2 – Back to back frame section

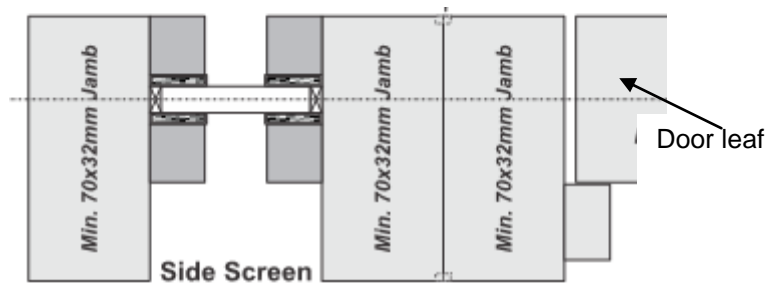

Option 3 – Back to back frame section with separating post, which may be rebated by a maximum of 5mm, as shown

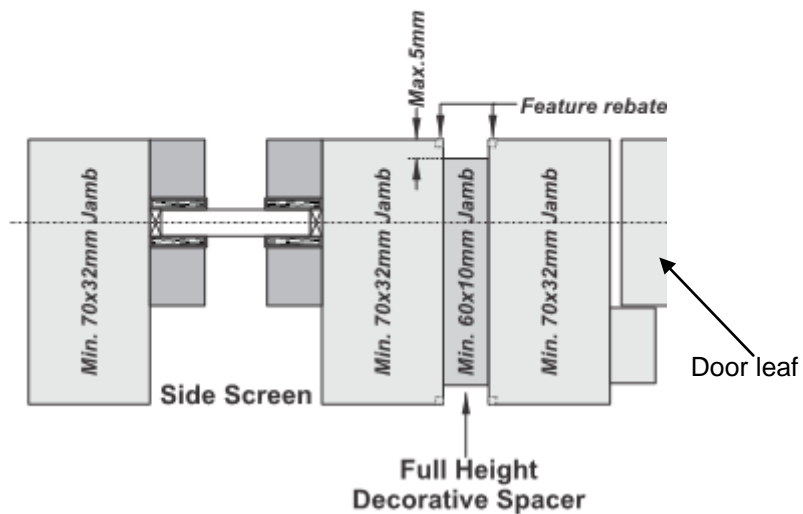

When using separate sections of timber, as shown above (options 2 and 3), each section must be suitably fixed to one-another using appropriate steel screw fixings and glued using Urea Formaldehyde or polyurethane. Screws must be fixed at 600mm centres and locate to approx 2/3 depth of the adjacent timber section. The overall frame section and material must match that given in this assessment for each glass type and glazing specification. Joints must be tight with no gaps.

It is permitted to include maximum 3mm (w) x 3mm (d) quirks/pencil rounds at the junction of each timber section for options 2 and 3.

Drawings are representative of each type of common frame section makeup; actual construction in terms of intumescent seal location and material, etc. must be as the text within this document specifies.

6.4.3 Screen Elevation – Norsound Vision Glazing System

The following drawing depicts a possible door and glazed screen configuration. The diagram is for information only. All construction details to remain as specified herein.

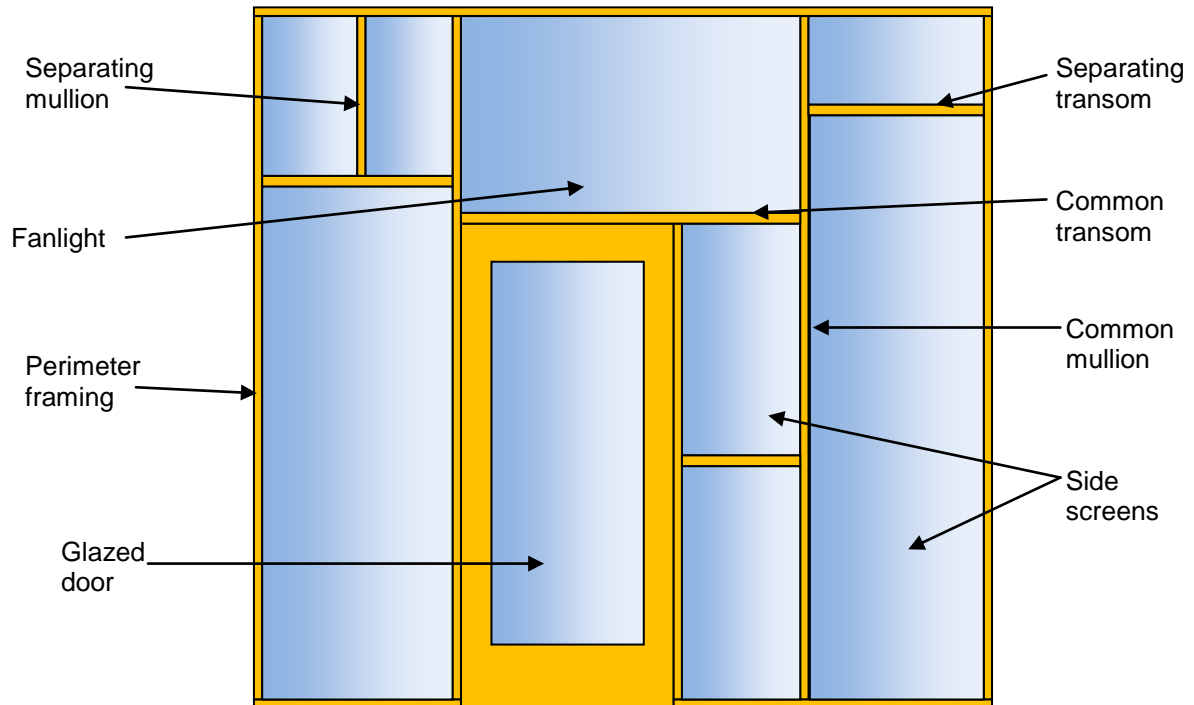

6.4.4 Glazing Beads & Installation – Norsound Vision Glazing System

Glazing beads and intumescent materials must be installed in line with the following sections:

System Name		Norsound Vision 60B	Norsound Vision 60T
Typical Installation			
Dimensions	Bead Height (mm)	Nominally 24.5	Nominally 14.5
	Intumescent Seals	25 high x 3 thick	15 high x 3 thick plus 'plug'
Aperture Liner		Nominally – 2mm thick x minimum 42mm wide	

6.4.5 Norsound Vision 60B & 60T Applications

The following bead designs are assessed as acceptable for the Norsound Vision 60B system:

Norsound Vision 60B Bead Types

NOTE 1: * = 2mm Splay applies to all bead profile types.

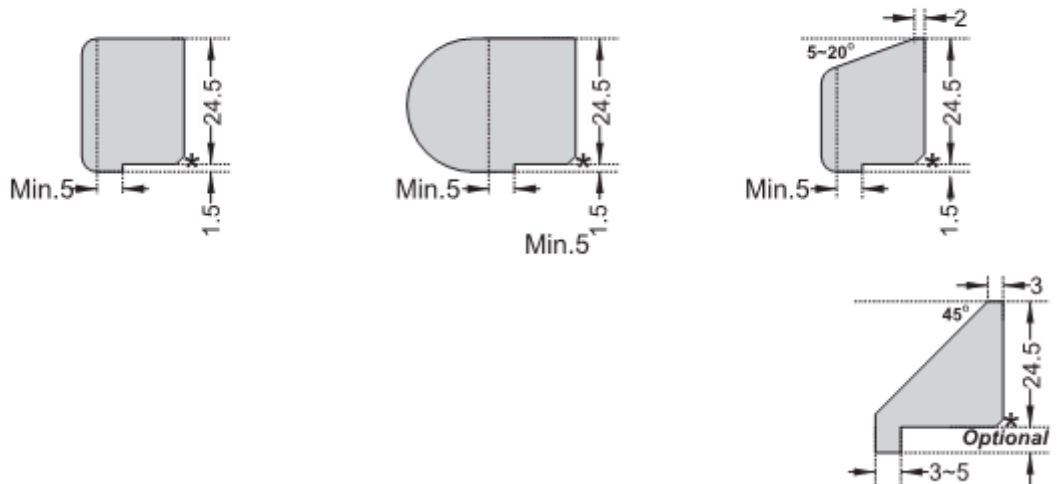

The legal validity of this report can only be claimed on presentation of the complete report.

The following bead designs have been assessed as acceptable for the Norsound Vision 60T system:

Norsound Vision 60T Bead Shapes

NOTE 1: * = 2mm Splay applies to all bead profile types.

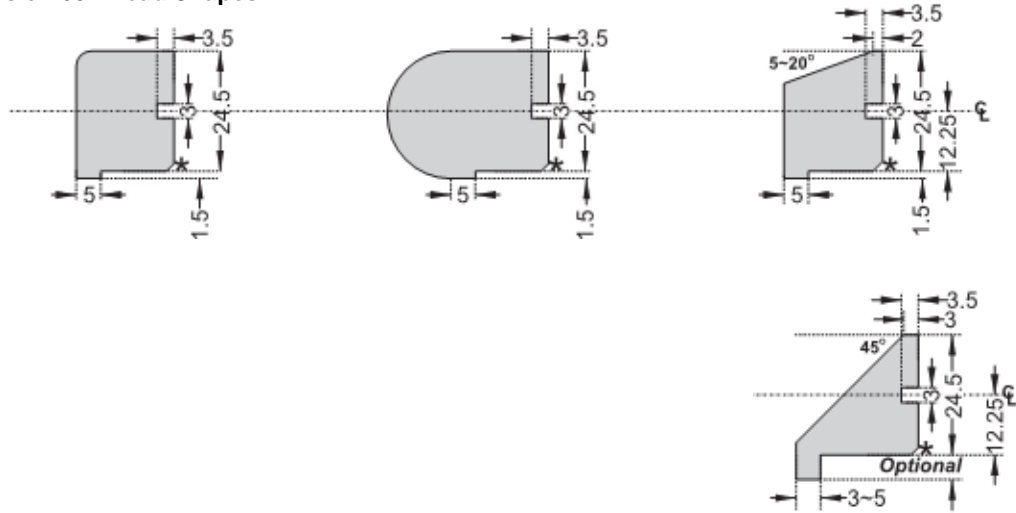

Notes:

1. Bead height must be nominally 24.5mm.
2. The intumescent seal component of Norsound Vision 60B & 60T is 25mm high and is required to project 0.5mm above the sightline of the bead.
3. Glazing aperture must be lined with the Norsound 5202LNR liner which is supplied at 52mm wide and may be reduced to a minimum of 42mm wide – liner must be fitted centrally in the glazed aperture.
4. Glazing beads must be retained in position with minimum 50mm long x 2mm diameter steel pins, or minimum 50mm long No. 6 - 8 screws, inserted at 35 - 40° to the vertical, at no more than 50mm from each corner and at 150mm maximum centres.
5. Pneumatically fired pins are acceptable providing the pins meet the specification given above.

6.4.6 Glazing Bead Material – Norsound Vision Glazing System

All timber for glazing beads must be straight grained, joinery quality hardwood, free from knots, splits and checks.

Integrity Performance	Bead Profile	Material	Min. Density (kg/m ³)
60	All in section 6.4.5	Hardwood	640

6.4.7 Timber Screen Framing – Norsound Vision Glazing System

Timber used for constructing framing elements comprising screen assemblies as illustrated in section 6.4.3 must meet the following specification:

Element	Material	Min. Section (mm)	Min. Density (kg/m³)
Perimeter screen framing	Hardwood	70 x 32	640
Mullions & transoms separating glass panes with side screens & fanlights	Hardwood	70 x 32	640
Back to back mullions separating side screens & doorsets (options 2 & 3)	Hardwood	70 x 32	640
Transoms common to doorsets & fanlights	Hardwood	70 x 40	640
Mullions common to doorset jambs & side screens	Hardwood	70 x 40	640

Notes:

1. Timber for side screens must meet or exceed class J30 as specified in BS EN 942: 2007 (subject to adequate repair of any defects).
2. The fanlights and side screens may comprise multiple panes of glass providing the total doorset and screen assembly does not exceed 2950mm high and the transom/mullion restrictions above are complied with.
3. Gaps between glass and framing, to permit expansion, should be set according to the glass manufacturer’s information, using non-combustible or hardwood setting blocks at the bottom edge.

7 Glazing

7.1 General

The testing conducted on the Flamebreak 60 design has demonstrated that the design is capable of tolerating glazed apertures, whilst providing a margin of over performance. Glazing is therefore acceptable within the following parameters.

The maximum assessed glazed area for all configurations is 0.72m². The glazing system must be one of the following tested proprietary systems:

7.2 Assessed Glazing Systems

Glazing System	Manufacturer	Max. Area (m ²)
1. Therm-A-Glaze 60	Intumescent Seals Ltd.	0.72
2. Fireglaze 60	Sealmaster Ltd.	0.72
3. System 90+	Lorient Polyproducts Ltd.	0.72
4. System 36/15	Lorient Polyproducts Ltd.	0.72
5. System 63	Lorient Polyproducts Ltd. (only suitable for circular apertures with glass types 1 & 2)	0.72
6. RF1	Lorient Polyproducts Ltd.	0.72
7. Pyroglaze 60	Mann McGowan Fabrications Ltd. (only with 60mm steel screw fixings)	0.72
8. FG60	Pyroplex Ltd.	0.64
9. Norsound Vision 60 ¹	Norsound Ltd.	0.72
10. Norsound Universal 60 ²	Norsound Ltd.	0.72

Notes:

1. See section 7.9 below for additional scope.
2. See section 7.10 below for additional scope.

7.3 Assessed Glass Products

Glass Type	Manufacturer	Thickness (mm)	Max. Area (m ²)
1. Pyroshield	Pilkington Group Ltd.	6 & 7	0.72
2. Pyroshield 2	Pilkington Group Ltd.	6 & 7	0.72
3. Pyran S	Schott Glass Ltd.	6	0.72
4. Pyrostem	CGI Ltd.	6	0.60
5. Pyroclear 60-001 ¹	Pilkington Group Ltd.	6	0.72
6. Pyrodur 60-10	Pilkington Group Ltd.	10	0.72
7. Pyrobelite 12	AGC Flat Glass UK	12	0.72
8. Contraflam	Vetrotech Saint Gobain Ltd.	14	0.72
9. Pyrostop 30-10	Pilkington Group Ltd.	15	0.72
10. Pyrobel 16	AGC Flat Glass UK	16	0.72
11. Pyrostop 60-101 ²	Pilkington Group Ltd.	23	0.72
12. Pyroguard 60-23 ³	CGI Ltd.	23	0.72
13. Pyrobel 25 ⁴	AGC Flat Glass UK	25	0.72

Notes:

All glass types must be fitted strictly in accordance with the manufacturer's tested details/installation requirements.

The legal validity of this report can only be claimed on presentation of the complete report.

Glass types 9 - 13 are full insulating in terms of the criteria set out in BS 476: Part 20: 1987.

1. See section 7.5 below for details.
2. See section 7.6 below for details.
3. See section 7.7 below for details.
4. See section 7.8 below for details.

7.4 Glazing Beads & Installation

Glazing beads must be from hardwood as specified in the following table:

Material	Profile	Min. Density (kg/m ³)	Application
Hardwood	Splayed	640	All proprietary systems detailed in 7.2 and appendix B
Hardwood	Square	640	Proprietary systems 1, 2 & 3 as specified in 7.2 and glass types 5 – 13 as specified in 7.3

See appendix B for square and splayed bead profile options. A 6 – 10mm thick square aperture liner is permitted for use with square beads providing it is constructed from hardwood of minimum density 640kg/m³ and glued in position using an adhesive type specified for the lippings (see section 12).

It is permitted to use a flush bead (i.e. a bead with no bolection return) with a chamfer providing all other details meet the specification given for the square bead option in the table above.

Glazing beads must be retained in position with 60mm long x 2mm diameter steel pins or 60mm long No. 6 - 8 screws, inserted at 35 – 40° to the vertical, at no more than 50mm from each corner and at 150mm maximum centres. Pneumatically fired pins are acceptable providing they meet the specification given above.

Glazed openings must not be less than 100mm from any door edge. Multiple apertures are acceptable within the permitted glazed area, with a minimum dimension of 80mm between apertures. Aperture shape is not restricted, providing the glazing system and beads are compatible with that shape.

False timber beads may be bonded to the glass face with an intumescent mastic/silicon, or a 0.5 – 2mm thick self-adhesive intumescent tape/strip. Suitable glass for this application is restricted to types 5 – 13.

Timber for glazing beads must be straight grained, joinery quality, free from knots, splits and checks.

Sectional drawings detailing the tested and approved proprietary glazing systems are contained in appendix B.

7.5 Pyroclear 60-001 (6mm thick) – Pilkington Group Ltd.

The following system must be used with the Pilkington 6mm Pyroclear glass type listed in section 7.3:

1. Hardwood (min. density 640kg/m³) glazing beads 25mm high x 25mm deep including a 5mm x 5mm bolection return and a 20° chamfer.
2. Beads must be retained in position with 50mm long x 2mm diameter steel pins or 50mm long No. 6 – 8 steel screws, inserted at 45° to the vertical, at no more than

The legal validity of this report can only be claimed on presentation of the complete report.

50mm from each corner and at 150mm maximum centres. Pneumatically fired pins are acceptable providing the pins meet the specification given above.

3. 20mm x 5mm Kerafix Flexit seal compressed to 4mm and fitted between the bead and the glass on both faces.
4. 54mm x 2mm Palusol ELSA 1000 glazing liner must be fitted lining the full width of the glazing aperture.
5. 10mm x 2mm Interdens must be fitted on top of the Palusol glazing liner, underneath the edge of the glass in between the beads.
6. The glass must be fitted with maximum 12mm edge cover and allowing for 8mm expansion on all edges.
7. Aperture shape is not restricted, providing the glazing system and beads are compatible with that shape.
8. Timber for glazing beads must be hardwood, straight grained, joinery quality, free from knots, splits and checks.
9. Glazed openings must not be less than 100mm from any edge, with a minimum dimension of 100mm between apertures.
10. Multiple apertures are permitted, subject to point 9 above.

7.6 Pyrostop 60-101 (23mm thick) – Pilkington Group Ltd.

The following system must be used with the Pilkington 23mm Pyrostop glass type listed in section 7.3:

1. Hardwood (min. density 640kg/m³) glazing beads 20mm high x 12.5mm deep including a 5mm x 5mm bolection return.
2. Beads must be retained in position with 60mm long No. 6 – 8 steel screws, inserted at 30° to the vertical, at no more than 50mm from each corner and at 150mm maximum centres.
3. 20mm x 3mm Hodgsons Sealants Firestrip 60 fitted between the bead and the glass on both faces.
4. 50mm x 2mm Norseal flexible glazing liner must be fitted around the perimeter of the glazing aperture.
5. The glass must be fitted with maximum 5mm edge cover and allowing for 5mm expansion on all edges.
6. Aperture shape is not restricted, providing the glazing system and beads are compatible with that shape.
7. Timber for glazing beads must be hardwood, straight grained, joinery quality, free from knots, splits and checks.
8. Glazed openings must not be less than 100mm from any edge, with a minimum dimension of 100mm between apertures.
9. Multiple apertures are permitted, subject to point 8 above.

7.7 Pyroguard 60-23 (23mm thick) – CGI Ltd.

One of the following two systems (sections 7.7.1 or 7.7.2) must be used with the CGI Ltd. 23mm Pyroguard glass type listed in section 7.3:

7.7.1 Flexible Figure 1 Glazing System – Lorient Polyproducts Ltd.

1. Hardwood (min. density 640kg/m³) glazing beads 25mm high x 18mm deep including a 5mm x 5mm bolection return and a 16° chamfer.
2. Beads must be retained in position with 70mm long No. 6 – 8 steel screws, inserted at 30 – 45° to the vertical, at no more than 50mm from each corner and at 150mm maximum centres.
3. 13mm x 3.5mm Lorient Polyproducts Ltd. Flexible Figure 1 glazing gasket fitted between the bead and the glass on both faces.
4. 54mm x 2mm Lorient Polyproducts Ltd. glazing liner must be fitted lining the glazing aperture.
5. The glass must be fitted with maximum 15mm edge cover and allowing for 5mm expansion on all edges.
6. Aperture shape is not restricted, providing the glazing system and beads are compatible with that shape.
7. Timber for glazing beads must be hardwood, straight grained, joinery quality, free from knots, splits and checks.
8. Glazed openings must not be less than 100mm from any edge, with a minimum dimension of 100mm between apertures.
9. Multiple apertures are permitted, subject to point 8 above.

7.7.2 Pyroglaze 60 Glazing System – Mann McGowan Ltd.

1. Hardwood (min. density 640kg/m³) glazing beads 30mm high x 16.5mm deep including a 5mm x 5mm bolection return and a 20° chamfer.
2. Beads must be retained in position with 60mm long No. 6 – 8 steel screws, inserted at 30 – 45° to the vertical, at no more than 50mm from each corner and at 200mm maximum centres.
3. 25mm x 4mm Mann McGowan Ltd. Pyroglaze 500PSA fitted between the bead and the glass on both faces.
4. 54mm x 2mm Mann McGowan Ltd. Pyroglaze 300 glazing liner must be fitted lining the glazing aperture.
5. The glass must be fitted with maximum 20mm edge cover and allowing for 5mm expansion on all edges.
6. Aperture shape is not restricted, providing the glazing system and beads are compatible with that shape.
7. Timber for glazing beads must be hardwood, straight grained, joinery quality, free from knots, splits and checks.
8. Glazed openings must not be less than 100mm from any edge, with a minimum dimension of 100mm between apertures.
9. Multiple apertures are permitted, subject to point 8 above.

7.8 Pyrobel 25 (25mm thick) – AGC Flat Glass UK

The following system must be used with the AGC Flat Glass Europe 25mm Pyrobel glass type listed in section 7.3:

1. Hardwood (min. density 640kg/m³) glazing beads 30mm high x 17.5mm deep including a 5mm x 5mm bolection return and a 20° chamfer.

The legal validity of this report can only be claimed on presentation of the complete report.

2. Beads must be retained in position with 60mm long No. 6 – 8 steel screws, inserted at 30° to the vertical, at no more than 50mm from each corner and at 150mm maximum centres.
3. 25mm x 2mm Superwool X607 fitted between the bead and the glass on both faces.
4. 2mm thick Sealmaster GL60 intumescent liner around perimeter of glazing aperture.
5. The glass must be fitted with maximum 21mm edge cover and allowing for 4mm expansion on all edges.
6. Aperture shape is not restricted, providing the glazing system and beads are compatible with that shape.
7. Timber for glazing beads must be hardwood, straight grained, joinery quality, free from knots, splits and checks.
8. Glazed openings must not be less than 100mm from any edge, with a minimum dimension of 100mm between apertures.
9. Multiple apertures are permitted, subject to point 8 above.

7.9 Norsound Ltd. – Norsound Vision 60B & 60T

The Norsound Ltd. glazing system assessed in Chilt/A12161 has the following scope of application in addition to that described in sections 7.1 – 7.3.

The Norsound Vision 60B is illustrated below:

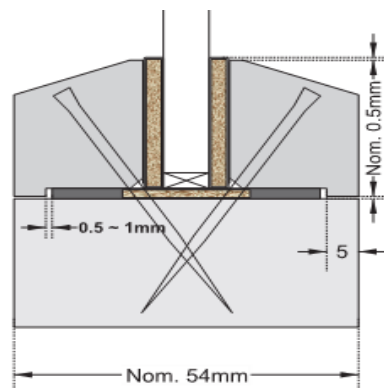

NOTE 1: * = 2mm Splay applies to all bead profile types.

Norsound Vision 60B Flush Bead Types

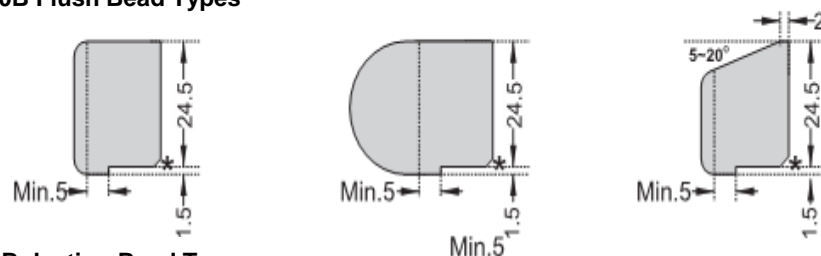

Norsound Vision 60B Bolection Bead Types

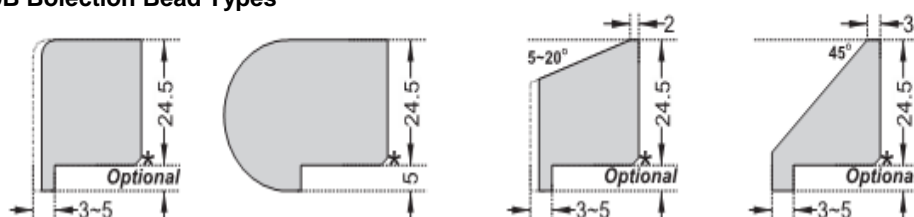

The legal validity of this report can only be claimed on presentation of the complete report.

The Norsound Vision 60T is illustrated below:

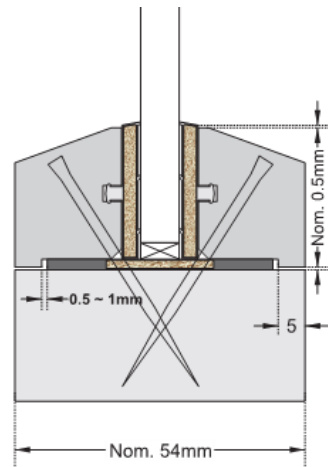

Norsound Vision 60T Flush Bead Types

NOTE 1: * = 2mm Splay applies to all bead profile types.

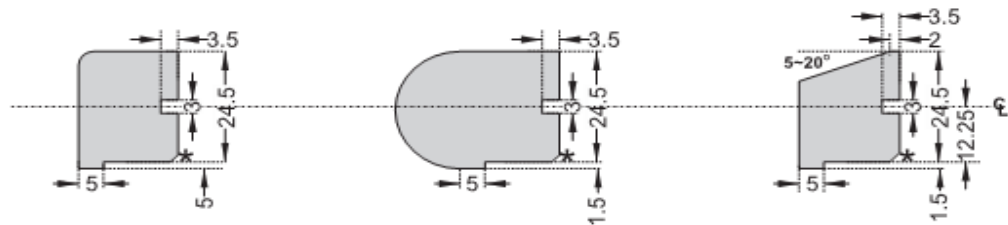

Norsound Vision 60T Bolection Bead Types

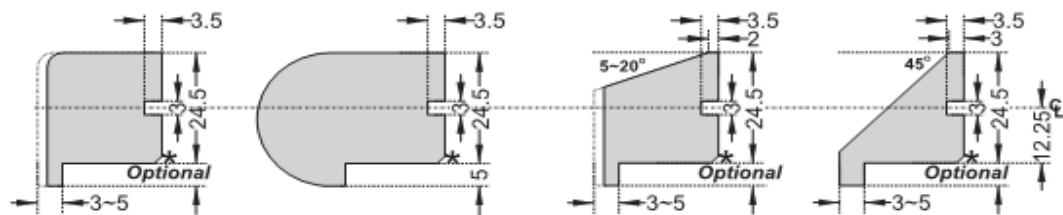

1. For flush style beads, the bead height must be nominally 26mm with a minimum rebate of 1.5mm. For bolection style beads, the bolection returns must be a minimum of 5mm high and project a minimum of 3mm from the leaf face.
2. The intumescent seal component of Norsound Vision 60B is 25mm high and is required to project 0.5mm above the sightline of the bead.
3. Glazing aperture must be lined with the Norsound 5202LNR liner which is supplied at 52mm wide and may be reduced to a minimum of 42mm wide – liner must be fitted centrally in the glazed aperture.
4. Bolection returns should be a minimum of 5mm high, and a minimum of 3mm thick (projecting from the leaf face).
5. Glazing beads must be retained in position with minimum 50mm long x 2mm diameter steel pins, or 50mm long No. 6 – 8 screws, inserted at 35 – 40° to the vertical at no more than 50mm from each corner and at 150mm maximum centres.
6. Pneumatically fired pins are acceptable providing the pins meet the specification given above.

The legal validity of this report can only be claimed on presentation of the complete report.

The bead type and permitted glass types must meet the following specification:

Bead Type	Material	Min. Density (kg/m ³)	Permitted Glass Types
Square flush	Straight grained, joinery quality hardwood, free from knots, splits and checks	640	1 – 4 (see section 7.3)
Bolection	Straight grained, joinery quality hardwood, free from knots, splits and checks	640	1 – 9 excluding 5 (see section 7.3)

7.10 Norsound Ltd. – Norsound Vision 60 Slimline

The Norsound Ltd. Vision 60 Slimline glazing system has the following scope of application to that described in sections 7.1 – 7.3.

The Norsound Vision 60 Slimline with flush square beads is illustrated below:

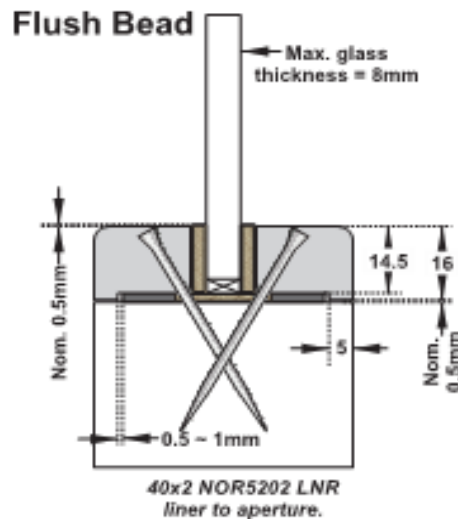

The Norsound Vision 60 Slimline with bolection beads is illustrated below:

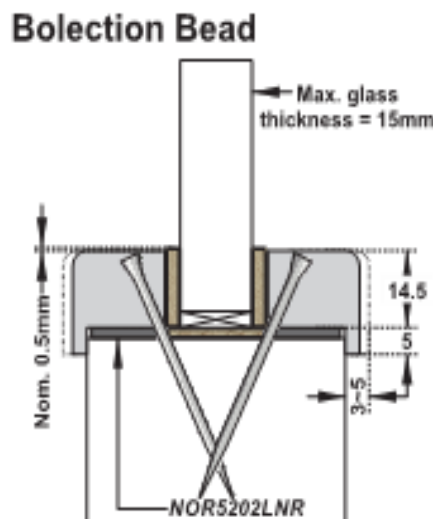

7.11 Norsound Ltd. – Norsound Vision 60B & 60T Slimline Applications

The following bead designs are assessed as acceptable:

★ = 2mm splay applicable to all bead profiles

Typical Flush Bead Types:

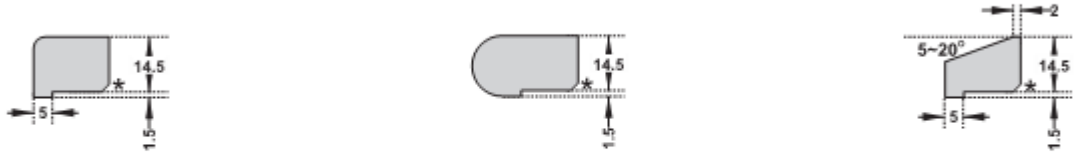

Typical Bolection Bead Types:

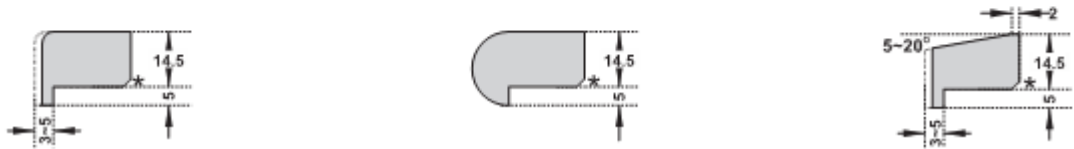

Norsound Vision 60T Slimline may utilise the same range of bead shapes:

★ = 2mm splay applicable to all bead profiles

Typical Flush Bead Types:

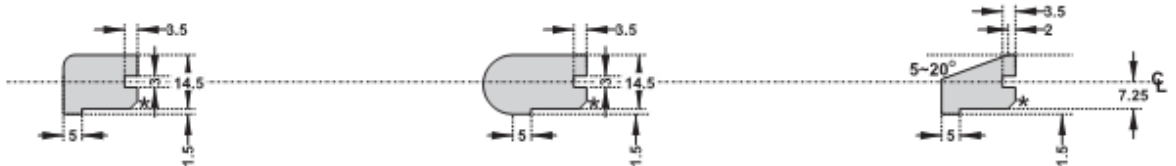

Typical Bolection Bead Types:

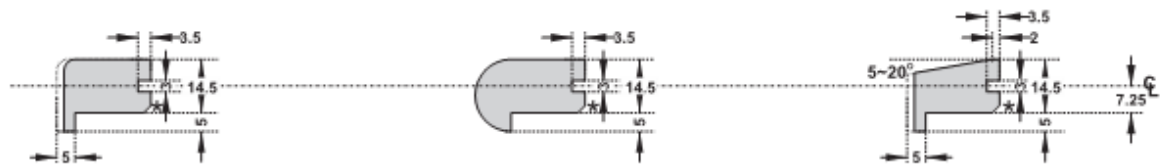

7.12 Norsound Ltd. – Norsound Universal 60B & 60T

The Norsound Ltd. Universal glazing system has the following scope of application in addition to that described in sections 7.1 – 7.3.

The Norsound Universal 60B is illustrated below:

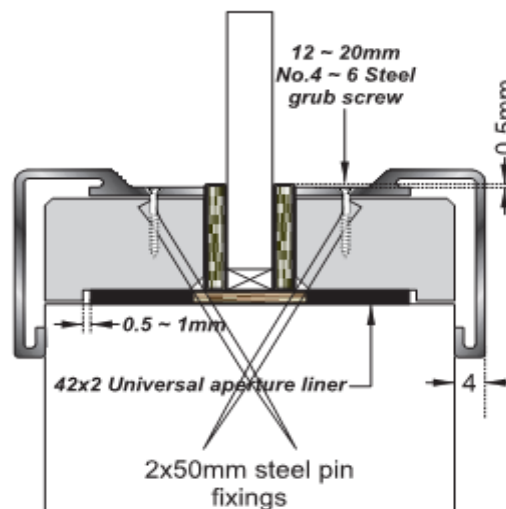

The legal validity of this report can only be claimed on presentation of the complete report.

The Norsound Ltd. Universal 60T glazing system has the following scope of application in addition to that described in sections 7.1 – 7.3. The Norsound Universal 60T is illustrated below:

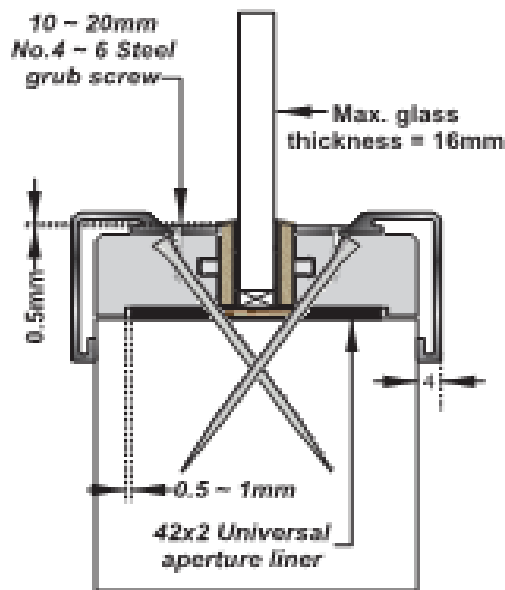

1. The core bead height must be nominally 14.5mm wide with a 1.5mm rebate.
2. The intumescent seal component of Norsound Universal 60B and 60T is 15mm high and is required to project 0.5mm above the sightline of the bead.
3. Glazing aperture must be lined with the Norsound 5202LNR liner which is supplied at 52mm wide and may be reduced to a minimum of 42mm wide – liner must be fitted centrally in the glazed aperture.
4. The position of the groove in the rear of the bead is therefore critical for installation of Norsound Universal 60T.
5. Glazing beads must be retained in position with minimum 50mm long x 2mm diameter steel pins or, minimum 50mm long No. 6 – 8 screws, inserted at 35 – 40° to the vertical at no more than 40mm from each corner and at 150mm maximum centres.
6. Pneumatically fired pins are acceptable providing the pins meet the specification given above.
7. The Norsound Universal aluminium section cladding the timber bead must be secured to the core bead by use of 3No. 10 – 12mm No. 4 grub screws per length.
8. The intumescent seal must project nominally 0.5mm above the sight line of the beading.

The bead material must meet the following specification and can be used with glass types 1 – 4 and 6 – 9 listed in section 7.3.

Material	Min. Density (kg/m ³)
Straight grained joinery quality hardwood, free from knots, splits & checks	640

8 Door Frames

8.1 Door Frame Construction

Door frames for Flamebreak 60 must be timber as follows:

Material	Min. Section (mm)	Min. Density (kg/m ³)	Application	Leaf Size Range (mm)
Hardwood	70 x 32	640	All configurations	All

All door frame timber must be straight grained, joinery quality hardwood, free from knots, splits and checks.

A 12mm deep planted stop is adequate for single acting frames whilst double acting frames may be scalloped or square. If frames are square, the maximum radius to the corners of the leaf is 8mm.

Frame joints may be mortice and tenoned, mitred, half lapped or butted and with no gaps (see section 8.2). All jointing methods require mechanical fixing with the appropriate size ring shank nails or screws.

All methods require joints to be tight, with no gaps, and nailed or screwed.

The following diagram depicts the assessed frame profiles and dimensions:

A = min. 70mm B = min. 32mm C = min. 12mm
 R = radius from floor spring 8mm max radius to create a maximum 2mm edge profiling

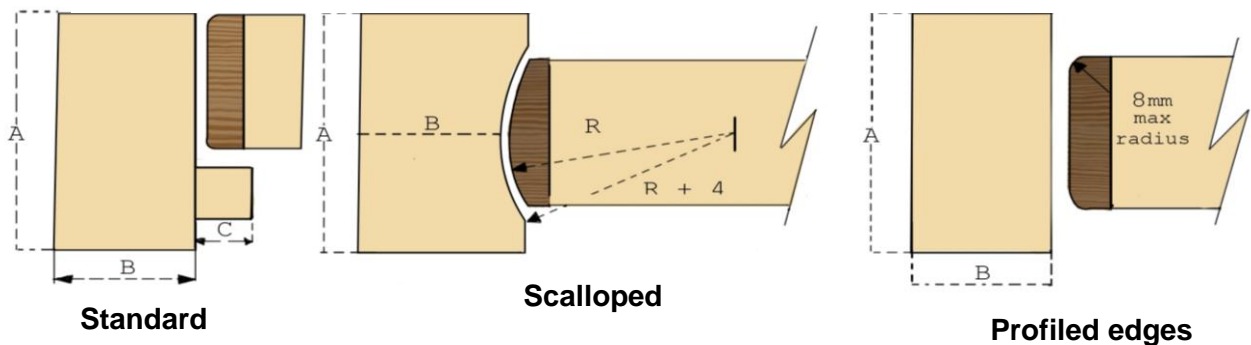

8.2 Door Frame Joints

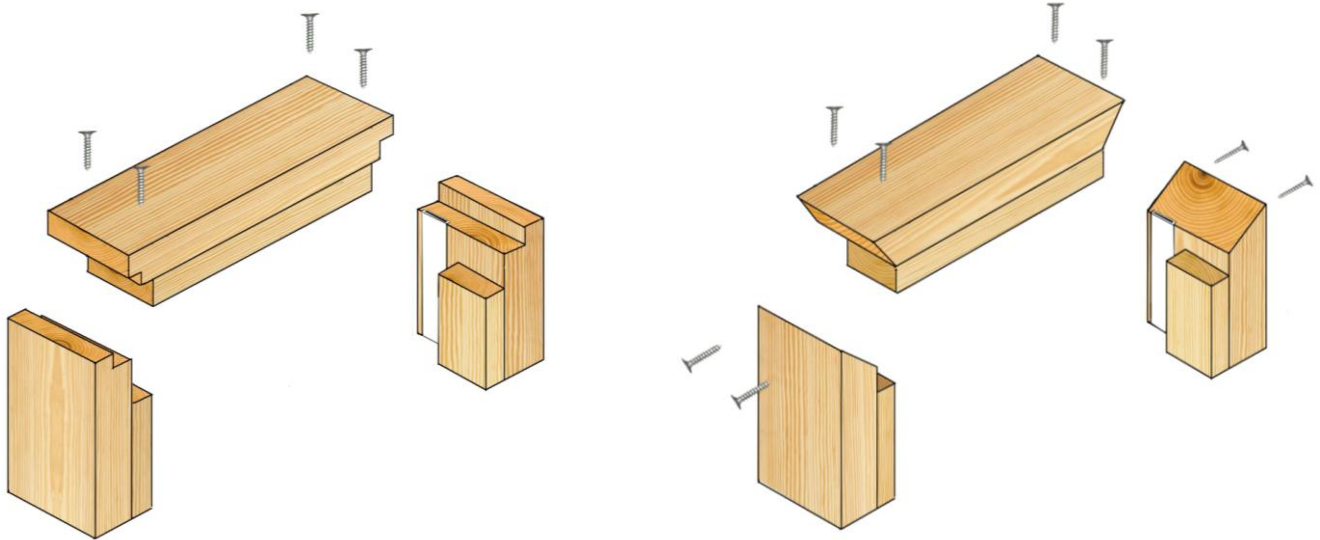

Half Lapped Joint

Mitre Joint

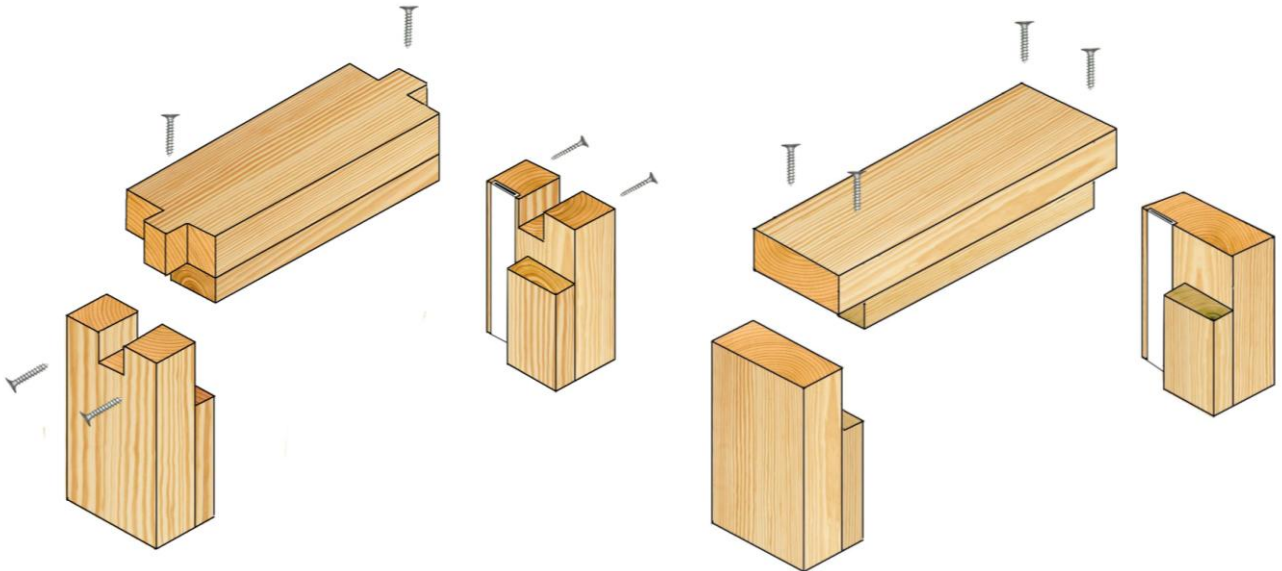

Mortise & Tenon Joint

Butt Joint

Note: Drawing is representative of each type of door frame joint only; actual construction in terms of intumescent seal location and material, etc. must be as the text within this document specifies.

8.3 Door Frame Construction

The following diagram depicts acceptable and unacceptable door frame installations:

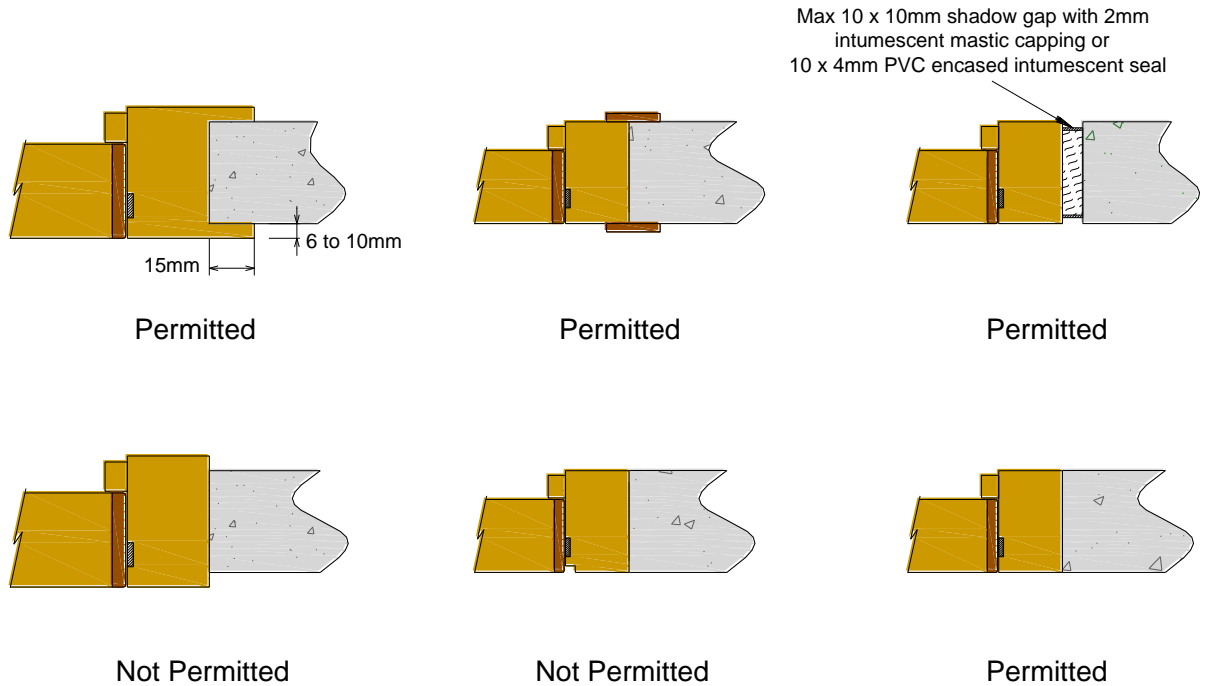

Notes:

1. Drawing is representative of door frame installation only; actual installation must be as the text within this document specifies. See section 18 for sealing to structural opening specification.
2. For the shadow detail depicted above (top right), the sub-frame material must be the same material as approved for the door frame, or a non-combustible board, tightly fitted and with no gaps.

9 Edging Materials

9.1 Timber Lippings

Flamebreak 60 must be lipped in accordance with the following specification:

Material	Size (mm)	Min. Density (kg/m ³)
Hardwood must be straight grained, joinery quality, free from knots, splits and checks.	1. Flat = 10 – 15 thick with a maximum of 2 profiling permitted at corners of lipping (see section 8.1)	640
	2. Rounded = 12 – 17 thick with a radius matching the distance between leaf edge and floor pivot (see section 8.1)	
	3. Rebated = Not assessed	

Notes:

- All edges of the door leaf must be lipped in accordance with the specification given above.
- Lippings along the vertical edges must over-run the lippings along the horizontal edges.

The legal validity of this report can only be claimed on presentation of the complete report.

9.2 PVC Edge Protectors & Post-Formed CS Group Acrovyn

9.2.1 General

It is possible to fit proprietary edge protectors to this doorset design providing they have suitable supporting test evidence to BS 476: Part 22: 1987 or BS EN 1634-1, when fitted to timber doorsets of similar construction to this design. The end user must satisfy themselves that the test evidence supports the proposed end use application.

9.2.2 CS Group Edge Protectors

The Pacific Rim Wood Flamebreak 60 design has been assessed for use with the CS Group edge protectors. CS Group edge protectors are supplied pre-formed with the approved intumescent material. The CS Group edge protectors must be used as part of a complete intumescent system and the required intumescent specification and leaf sizes are given in the relevant data sheets in appendix D. CS Group must be contacted for precise installation and fixing details (www.c-sgroup.co.uk).

The Flamebreak 60 design with 6mm plywood facings can be fitted with the CS Group edge protectors up to the maximum dimensions stated in the CS Group headed data sheets in appendix D. When the Flamebreak 60 design is faced with 6mm MDF, CS Group edge protectors can be fitted, but the leaf dimensions must be limited to those stated in section 10.1 below.

9.2.3 Post-Formed CS Group Acrovyn

It is possible to encapsulate the Flamebreak 60 doorset design by post-forming the leaf in CS Group Acrovyn, based on the supporting test evidence contained within Chilt/A11130 Revision A and the following specification:

1. CS Group Acrovyn must be wrapped around the vertical edges of the leaf only, i.e. the top and bottom of the leaf must remain exposed.
2. The vertical edge detail prior to post-forming must be either lipped with 8mm thick PVC, or hardwood as detailed in this assessment (see section 9.1).
3. The maximum radius of the lipping at the corners of the vertical edges before post-forming must be 9mm, which provides for 11mm external radius after the CS Group Acrovyn has been applied.
4. The intumescent detail as specified in section 11 and the relevant (CS Group headed) data sheets contained in appendix D of this assessment must be replicated.
5. CS Group Acrovyn must be bonded to the leaf using 3M Scotch-Grip cement 10 contact adhesive, or equivalent.
6. See relevant (CS Group headed) data sheets in appendix D of this assessment for maximum permitted leaf sizes.
7. The maximum thickness of CS Group Acrovyn used must be 2mm, as per test evidence.
8. The CS Group Acrovyn can be provided as pre-formed trays with dimensions to suit the proposed leaf sizes, as well as sheets for post-forming by the door manufacturer.

9.3 Hardwood Blocking for Pivots

The following option is permitted for lipping the bottom of doors that are to receive pivot fixings and are to be used in severe duty locations (diagram below). It is not necessary to introduce additional blocking at the head of the door because of the presence of the integral top rail.

The hardwood insert may be a maximum of 15mm high by a length suitable for the hardware to be installed plus a maximum of 50mm (not full door width). The hardwood insert must be a maximum of 28mm wide and fitted centrally in the leaf leaving 8mm of leaf material on either face. The inserted block must be bonded on all contact faces using adhesives approved for the application of lippings (see section 12). Alternatively lippings in accordance with details shown in section 9.1 may be used.

Cross Section through Bottom of Leaf fitted onto Floor Spring and Pivot

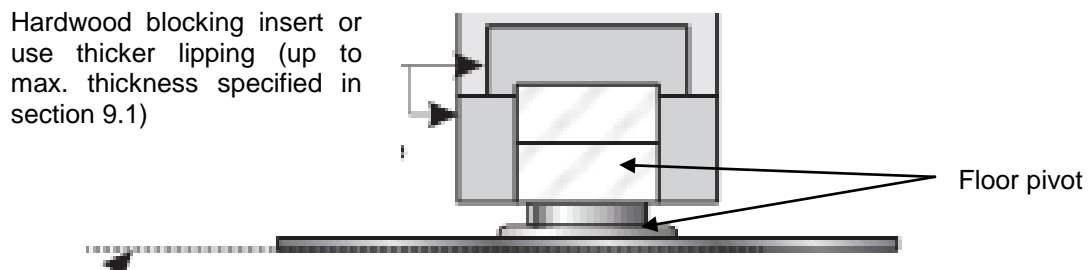

9.4 Meeting Stile Astragals

Generally, fire doors should be able to open simultaneously. However, where additional performances are required (e.g. acoustic performances) it may be necessary to provide for sequential opening.

The astragal detail may be used where these conditions apply, without adverse influence on existing fire test/assessment data.

Astragals can be applied to both door leaves and may be profiled for aesthetic effect providing they meet the minimum specification given below.

The hardwood for the astragal must be hardwood of the same minimum density being used for the lipping material. See following diagram:

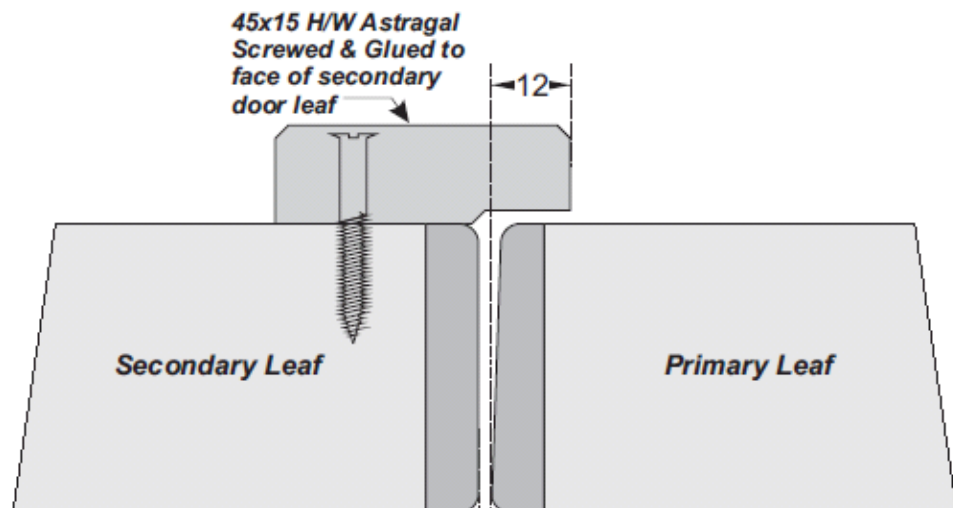

The legal validity of this report can only be claimed on presentation of the complete report.

10 Leaf Facing Materials

10.1 Structural Facings

The following facing materials have been tested or assessed for use with the Flamebreak 60 doorset design:

Facing Materials	Thickness (mm)	Max. Leaf Size (mm)	Permitted Configurations	Min. Density (kg/m ³)
Plywood	6	All	All	520 – 530
MDF	6	From: 2080(h) x 960(w) To: 2132(h) x 936(w)	Single leaf doorsets only	750

10.2 Decorative & Protective Facings

The following additional facing materials are permitted for this door design since they would degrade rapidly under test conditions without significant effect:

Facing Material	Maximum Permitted Thickness (mm)
Paint	0.5
Timber veneers	2
PVC/plastic laminates	2
Decorative paper/non-metallic foil	0.4

Notes:

1. Metallic facings are not permitted except for push plates and kick plates.
2. The door leaf thickness may be reduced by a total maximum of 0.5mm for calibration purposes in order to accommodate the chosen finish.
3. Materials must not conceal intumescent strips.
4. PVC/plastic laminates may only be applied to leaf edges meeting the specification given in section 9.2.

11 Intumescent Materials

The intumescent materials tested and assessed for this doorset design are as follows:

Application	Location	Product/Manufacturer
Edge seals	Fitted in the frame jambs or leaf edges	<ol style="list-style-type: none"> 1. PVC encased Palusol 100 – Mann McGowan Ltd. 2. Pyrostrip 500P – Mann McGowan Ltd. 3. Pyroplex Rigid Box Seals– Pyroplex Ltd. 4. Type 617 – Lorient Polyproducts Ltd.
Hinges	Under both hinge blades	<ol style="list-style-type: none"> 1. 1mm Interdens – Dufaylite Developments Ltd. 2. 1mm Therm-A-Strip – Intumescent Seals Ltd. 3. 1mm G30 – Sealmaster Ltd. 4. 1mm NOR910 – Norsound Ltd.
Lock/latches	Under latch forend & latch keep	<ol style="list-style-type: none"> 1. 1mm Interdens – Dufaylite Developments Ltd. 2. 1mm Therm-A-Strip – Intumescent Seals Ltd. 3. 1mm G30 – Sealmaster Ltd. 4. 1mm NOR910 – Norsound Ltd.¹
Top pivots	Lining all sides of the mortices	<ol style="list-style-type: none"> 1. 2mm Interdens – Dufaylite Developments Ltd. 2. 2mm Therm-A-Strip – Intumescent Seals Ltd. 3. 2mm G30 – Sealmaster Ltd.
Flush bolts	Lining all sides of the mortices	<ol style="list-style-type: none"> 1. 2mm Interdens – Dufaylite Developments Ltd. 2. 2mm Therm-A-Strip – Intumescent Seals Ltd. 3. 2mm G30 – Sealmaster Ltd. 4. 1mm NOR910 – Norsound Ltd.
Cableways	Lining the base of the groove (see section 14.14)	<ol style="list-style-type: none"> 1. 2mm Interdens – Dufaylite Developments Ltd. 2. 2mm Therm-A-Strip – Intumescent Seals Ltd. 3. 2mm G30 – Sealmaster Ltd. 4. 2mm NOR920 – Norsound Ltd.²

Notes:

1. The maximum latch forend size for use with 1mm NOR910 is 155mm high by 25mm wide.
2. The seal specification for each configuration is shown in appendix D.

12 Adhesives

The following adhesives must be used in construction:

Element	Product
Facings	Melamine
Lipping	Urea formaldehyde, resorcinol formaldehyde, PU (for single leaf doorsets only)
Core	PVA

13 Tested Hardware

13.1 General

The following section details the tested hardware for this doorset design. However, the following items of hardware must also bear the CE Mark:

- Locks & latches: Test Standard EN 12209
- Single axis hinges: Test Standard EN 1935
- Controlled door closing devices: Test Standard EN 1154.

The following hardware has been successfully incorporated in the tests on this design:

Element	Manufacturer & Product Reference
Hinges	1. Royde & Tucker H101 Hi-Load steel butt type hinges
Closers	1. Dorma TS83V overhead type door closer
Latches/locks	1. Henderson Hardware tubular mortice latch 2. E*S Hardware tubular mortice latch
Furniture	1. Aluminium lever type handle

14 Additional & Alternative Hardware

14.1 General

The following sections detail the permitted scope and constraints for fitting additional and alternative hardware to the door design. However, the following items of hardware must also bear the CE Mark:

- Locks & latches: Test Standard EN 12209
- Electro mechanically operated locks: Test Standard EN 14846
- Single axis hinges: Test Standard EN 1935
- Controlled door closing devices: Test Standard EN 1154
- Electrically powered hold open devices: Test Standard EN 1155
- Door co-ordinators: Test Standard EN 1158
- Emergency exit hardware: Test Standard EN 179
- Panic exit hardware: Test Standard EN 1125.

14.2 Latches & Locks

Latches and locks must either be as tested, or alternatively components with the following specification are acceptable:

Element	Dimensions (mm)
Maximum forend and strike plate dimensions	235 high by 24 wide by 4 thick
Maximum body dimensions	165 high by 100 wide by 18 thick
Intumescent protection	See section 11
Materials	All parts essential to the locking/latching action (including the latch bolt, forend and strike) to be steel
Location	1000 – 1200 from threshold

14.3 Hinges

Flamebreak 60 leaves must be hung on a minimum of 3 hinges. Leaves over 2300mm high must fit 4 hinges. Hinges with the following specification are acceptable:

Element	Specification		
Blade height	90 – 120mm		
Blade width (excluding knuckle)	30 – 35mm		
Blade thickness	2.5 – 4mm		
Fixings	Minimum of 4No. 30 long No. 8 or No. 10 steel wood screws per blade		
Materials	Steel or stainless steel		
Hinge positions	Top	200 – 220mm from the head of the leaf to the centreline of the hinge	
	2 nd	Minimum 200mm from centreline of top hinge to centreline of second hinge OR equally spaced between top and bottom hinge	
	Bottom	220 – 300mm from the foot of the leaf to the centreline of the hinge	
	Leaf dimensions <2300mm	Top	200 – 220mm from the head of the leaf to the centreline of the hinge
		2 nd	Minimum 200mm from centreline of top hinge to centreline of second hinge
		3 rd	Equally spaced between 2 nd hinge and bottom hinge
		Bottom	220 – 300mm from the foot of the leaf to the centreline of the hinge
	Leaf dimensions >2300mm	Top	200 – 220mm from the head of the leaf to the centreline of the hinge
2 nd		Minimum 200mm from centreline of top hinge to centreline of second hinge	
3 rd		Equally spaced between 2 nd hinge and bottom hinge	
Bottom		220 – 300mm from the foot of the leaf to the centreline of the hinge	
Intumescent protection	See section 11		

14.4 Automatic Closing

Automatic closing devices must either be as tested or components of equal specification that have demonstrated a contribution to the required performance of these types of 60 minute doorset designs, when tested to BS 476: Part 22: 1987 or BS EN 1634-1.

Notes:

1. The top pivots to floorspring assemblies must be protected with 2mm thick intumescent gasket (see section 11) or alternatively the manufacturers tested intumescent gaskets.
2. Concealed overhead closers are not permitted with flush overpanels unless there is specific test evidence for this door design to one of the above Test Standards.

14.5 Flush Bolts

Flush bolts may be incorporated centrally into the top and bottom of one meeting edge, providing the following maximum dimensions are not exceeded and the components are fitted opposite the edge fitted with intumescent strips.

- 200mm long x 20mm deep x 20mm wide

Flush bolts must be steel or brass and the mortice must be as tight to the mechanism as is compatible with its operation. All edges of the mortice must be protected with intumescent gaskets as specified in section 11. Alternatively the hardware manufacturers tested gaskets may be used. See diagram below for example of intumescent protection to flush bolt:

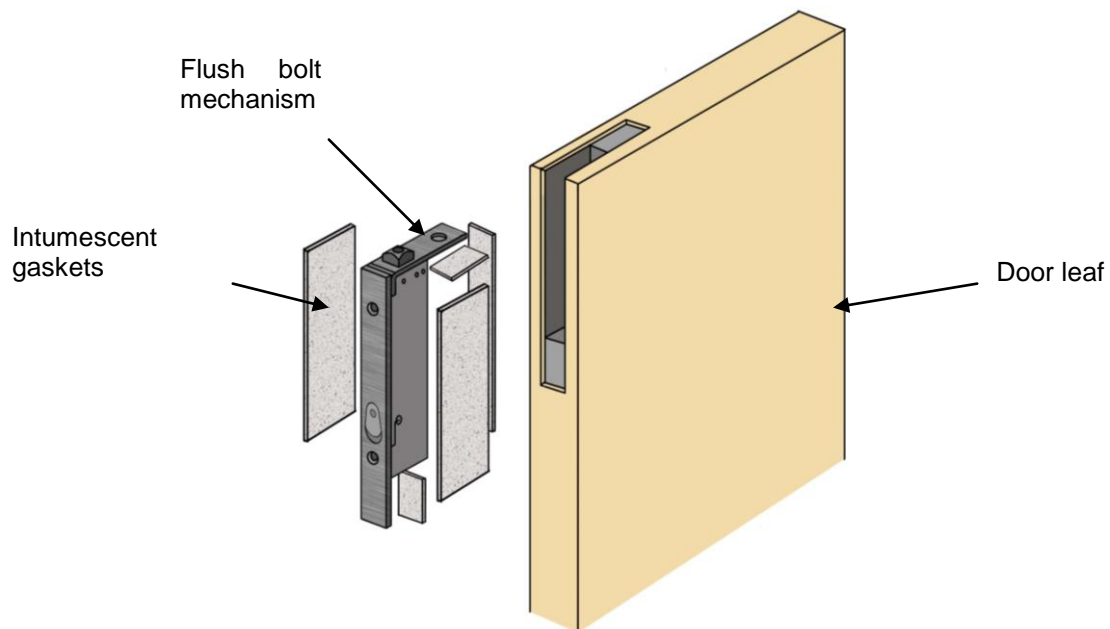

14.6 Surface-Fixed Barrel Bolts

It is permitted to fit a surface-fixed barrel bolt to the top closing corner of a double leaf providing the item does not require removal of material from the leaf or door frame and does not interfere with the perimeter intumescent seals. The item must be no longer than 450mm.

14.7 Pull Handles

These may be surface-fixed to the door leaf provided that they are steel or brass and the length is limited to 1200mm between the fixing points. No additional intumescent protection is required provided that the hole for the bolt through the leaf is tight.

14.8 Push Plates/Kick Plates

Face-fixed hardware such as push plates and kick plates may be fitted to the doorsets provided that their fitting requires the removal of no part of the door leaf. These items of hardware must not amount to more than 20% of the door leaf area if mechanically fixed and a maximum of 30% if bonded with a contact or other thermally softening adhesive. Plates must not return around the door edges.

14.9 Door Selectors

These may be freely applied, provided that they are not invasive in the leaf edges or door frames and they do not interfere with the self-closing action of the door leaf. Products that are invasive will require fire resistance test/assessment evidence to support their use.

14.10 Door Security Viewers

Door security viewers with brass or steel bodies of a diameter less than or equal to 15mm may be used provided that the through-hole is bored tight to the case of the viewer (maximum tolerance +1mm). Lenses must be glass and the item must be bedded in to a tested intumescent mastic.

14.11 Panic Hardware

Panic hardware may be fitted, provided that its installation does not require the removal of any timber from the leaf, stop or frame reveal and it in no way interferes with the self-closing action of the door leaf.

14.12 Air Transfer Grilles**14.12.1 General**

Air transfer grilles may be fitted providing the product has suitable test evidence to BS 476: Part 22: 1987 or BS EN 1634-1 that demonstrates a minimum 60 minutes integrity performance when installed within a timber based doorset of comparable thickness. Margins to the leaf edges will remain as detailed for glazing and the position of the unit will be dictated by the pressure regime tested in the proving evidence (normally below mid-height). The area occupied by the air transfer grille must not exceed 0.2m² and must be deducted from the percentage of glazing, if both elements are fitted.

14.12.2 Pyroplex Air Transfer Grilles

The following Pyroplex air transfer grilles have been assessed as acceptable for use with the Flamebreak 60 design.

The grilles must be fitted a minimum of 100mm from the edge of the door leaf and a minimum of 80mm apart if more than one grille is to be fitted. The area occupied by the air transfer grille(s) must be deducted from the percentage of glazing, if both elements are fitted. The grilles may be fitted up to a maximum height of 2200mm from the threshold.

Part No.	Dimensions (mm)	Air Flow (sq. Cm)	Compatible Faceplates
ATG 1500	150 x 150	153	FP1500
ATG 1503	150 x 300	307	FP1503
ATG 1300	300 x 300	614	FP1300
ATG 2251	112 x 225	161	FP2251
ATG 2250	225 x 225	323	FP2250

The Pyroplex air transfer grilles must be installed in accordance with the manufacturer’s installation details, which include a 6mm thick hardwood aperture liner and Pyroplex intumescent mastic applied around the perimeter of the grille. Full details can be obtained from Pyroplex Ltd.

14.13 Environmental Seals

Silicon based flame retardant acoustic, weather and dust seals (e.g. Norseal 710, Lorient IS1212, IS1511, IS7025, IS7060) may be fitted to this doorset design without compromising the performance, providing their fitting does not interfere with the activation of the intumescent seals or hinder the self closing function of the leaves.

14.14 Threshold Seals

The following types of automatic threshold drop seals may be recessed in to the bottom rail of leaves to this design without compromising the performance:

Manufacturer	Product
Lorient Polyproducts Ltd.	IS8010si
Pemko	411 – AR
Raven	RP8Si
Athmer	Sound-Ex Duo L-15
Norsound Ltd.	NOR810, NOR810S, NOR810dB+

14.15 Cable-Way

Based on the integrity performance of the doorset construction, with no burn through of the core material, we consider it acceptable to allow the provision for a concealed cable-way to facilitate electro-magnetic closing/latching mechanisms. The cable-way must be concealed in the following way:

1. A hole drilled centrally through the leaf of maximum 10mm diameter.
2. The cable for the electronic closing/latching mechanisms must be no more than 2mm smaller in diameter than the hole through the leaf.
3. The cable for the electronic closing/latching mechanism must be PVC encased.
4. Cable ways are only permitted for use with latched, single leaf, single acting doorsets with maximum leaf dimensions of 2100mm (h) x 900mm (w).
5. The hole must be located below 1500mm from the threshold and must be spaced a minimum of 90mm from any apertures within the leaf, e.g. glazing, air transfer grilles or letter plates, etc.

This approval is subject to the hardware manufacturer having the appropriate test evidence for the product for use with this type of 60 minute construction. Test evidence generated in steel doorsets is not acceptable. Any tested intumescent gaskets for the lockset, closing mechanism, receiver plate, cable loops, etc. must be replicated.

14.16 Letter Boxes/Plates

Letter boxes/plates may be fitted providing the product can demonstrate contribution to the required performance of this type of 60 minute doorset design, when tested to BS 476: Part 22: 1987 or BS EN 1634-1 and installed at the proposed location, within a timber based doorset of comparable thickness. Margins to the leaf edges must remain as specified for glazing.

15 Door Gaps

For fire resistance performance, door edge gaps, threshold gaps, and alignment tolerances must fall within the range shown in the following table:

Location	Dimensions
Door edge gaps	A minimum of 2mm and a maximum of 4mm
Alignment tolerances	Leaves must not be proud of each other or from the door frame by more than 1mm
Threshold	10mm between bottom of leaf and top of floor covering

16 Structural Opening

The supporting construction must provide the required level of fire resistance designated for the doorset design and be a suitable medium to permit adequate fixity.

17 Fixings

The positioning of installation fixings in height should be planned to avoid conflicts with hardware, sealing systems and other building elements.

- A top fixing must be located within 100mm from the underside of the head.
- A bottom fixing must be located 100mm from the bottom of the jamb.
- Intermediate fixings must be located at centres of not more than 600mm.
- The minimum number of fixings in height must be:
 1. Doorset height up to 2000mm = 4No.
 2. Doorset height 2000 - 2500mm = 5No.
 3. Add 1No. fixing for each further 500mm increase in door height.
- The fixings must be of the appropriate type for the supporting construction and must penetrate to a minimum depth of 40mm.
- For storey height doorsets a top fixing must be provided within a 100mm from the underside of the frame head with a further top fixing positioned 100mm from the underside of the transom rail (or bottom edge of the overpanel if a flush overpanel design is used).
- It is not necessary to fix the frame head, although packers must be inserted. However, for doorset widths in excess of 1100mm the use of an additional fixing centre width of the doorset at the head position is recommended.

See following diagram for illustration on fixings for a typical timber door frame doorset installation:

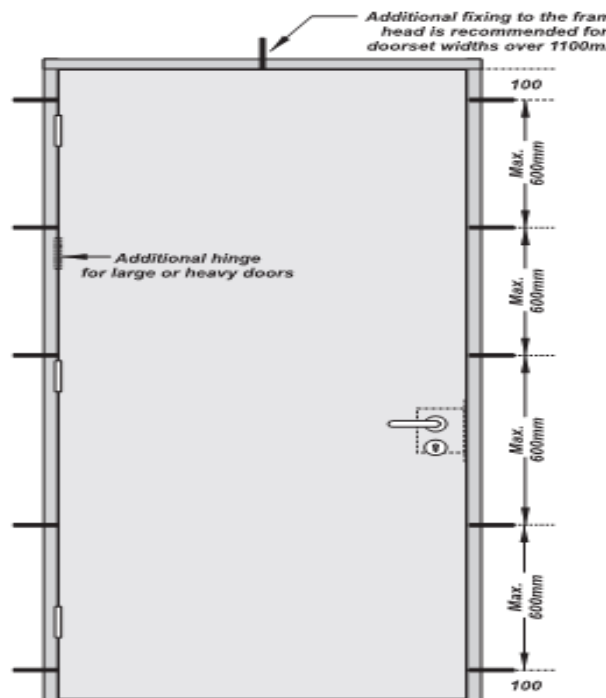

Timber frame fixing locations illustrated.

18 Sealing to Structural Opening

The door frame to structural opening gap must be protected using one of the following methods:

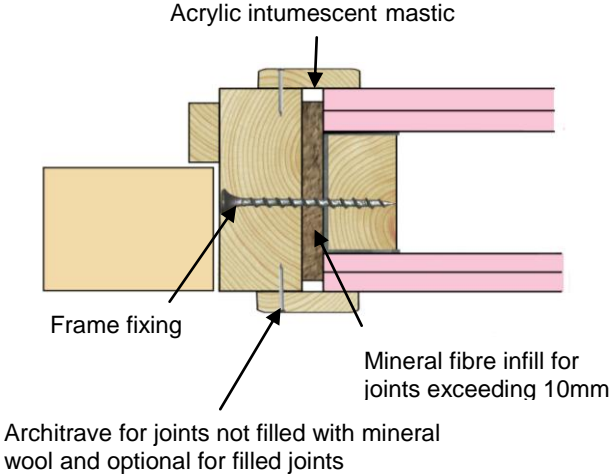
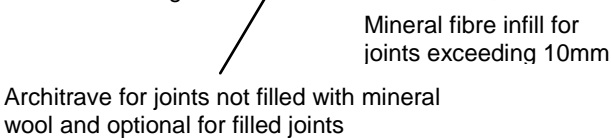
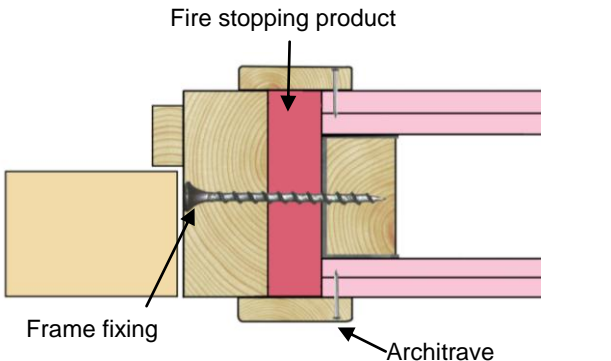
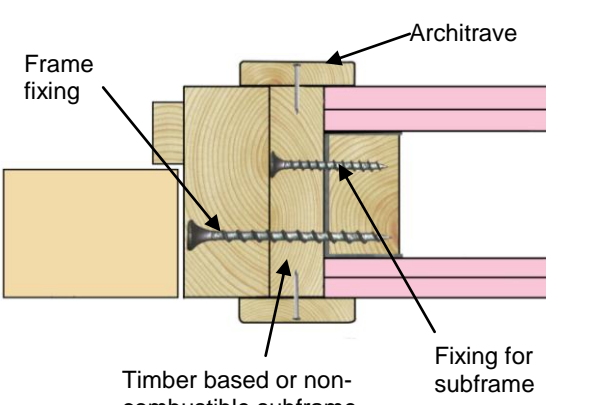
<p>1. Gaps up to 10mm must be sealed on both sides with a 10mm depth of acrylic intumescent mastic, fire tested for this application to BS 476: Part 22: 1987 or BS EN 1634-1. Joint must be fitted with 15mm thick architraves overlapping at least 15mm each side.</p>	
<p>2. Gaps between 10mm and 20mm must be tightly packed with mineral fibre capped on both sides with a 10mm depth of acrylic intumescent mastic, fire tested for this application to BS 476: Part 22: 1987 or BS EN 1634-1. Architraves are optional.</p>	
<p>3. Gaps up to 20mm filled with proprietary fire stopping product (e.g. expanding PU foam or preformed compressible intumescent foam). Products must be tested for this application to BS 476: Part 22: 1987 or BS EN 1634-1. Joint must be fitted with 15mm thick architraves overlapping at least 15mm each side.</p>	
<p>4. Timber based or non-combustible subframe up to 50mm thick, with no gaps between the components. Joint must be fitted with 15mm thick architraves overlapping at least 15mm each side.</p>	

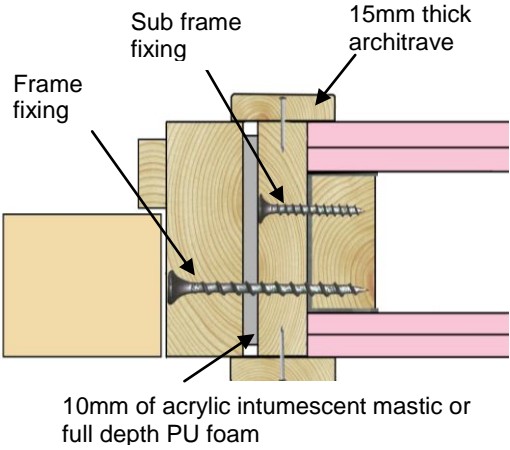
<p>5. Timber based or non-combustible subframe up to 50mm thick, with gaps up to 10mm between the components filled on both sides with 10mm depth of acrylic intumescent mastic or full depth expanding PU foam, fire tested for this application to BS 476: Part 22: 1987 or BS EN 1634-1. Joint must be fitted with 15mm thick architraves overlapping at least 15mm each side.</p>	 <p>The diagram shows a cross-section of a door frame assembly. It features a central vertical sub frame (light brown) and a horizontal frame (darker brown). The sub frame is secured with 'Sub frame fixing' (screws). The frame is secured with 'Frame fixing' (screws). A '15mm thick architrave' (pink) is overlapped on both sides of the frame. The gap between the sub frame and the frame is filled with '10mm of acrylic intumescent mastic or full depth PU foam'.</p>
---	---

Guidance for various methods of sealing the frame to structural opening gap is also given in BS 8214: 2008, “Code of practice for fire door assemblies”, which may be referred to where appropriate.

Note: Drawings are representative of doorset installation only; actual installations must be as the text within this document specifies.

19 Insulation

Insulation performance may be claimed for a doorset to this design meeting the following:

Type	Details
Partially insulating	Doorsets incorporating up to 20% of non-insulating glazing
Fully insulating	Unglazed doorsets or doorsets including 60 minute fully insulating glazing (e.g. 23mm Pyrostop or 25mm Pyrobel)

20 Smoke Control

20.1 General

If the doorset design is required to provide a smoke control function to comply with Building Regulations, the doorset must meet one of the following criteria (unless pressurization techniques complying with BS EN 1201-6 are used):

- (a) have a leakage rate not exceeding 3m³/m/hour (head and jambs only) when tested at 25Pa under BS 476 *Fire tests on building materials and structures*, Section 31.1 – *Methods for measuring smoke penetration through doorsets and shutter assemblies, Method of measurement under ambient temperature conditions*; or
- (b) meet the additional classification requirement of Sa when tested to BS EN 1634-3: 2004 – *Fire resistance tests for door and shutter assemblies, Part 3 – Smoke control doors*.

Smoke seals or combined intumescent/smoke seals that are fitted to the door to achieve the performance requirements specified above, must have been tested in accordance with the associated test method. Providing the smoke seals, any interruptions, door gaps, and the type/configuration of the doorset are consistent with the detail tested, the doorset will comply with current smoke control legislation under Approved Document B, and a suffix ‘S’ or ‘Sa’, as appropriate, may be added to the

designation. Any other components installed where smoke leakage may occur must also be taken into account.

Note: The incorrect specification and fitting of smoke seals may impair the operation of a doorset and therefore compromise the fire resistance performance. Advice should be sought from the seal manufacturers regarding the correct specification and installation of smoke seals or combined smoke and intumescent seals.

20.2 Further Considerations

Other guidance is available, including BS EN 9999-2008 – *Code of practice for fire safety in the design, management and use of buildings*, which may impose different or additional requirements. It is the responsibility of the relevant parties to stipulate the precise smoke control specification, prior to commencing manufacture and/or installation.

21 Conclusion

If Flamebreak 60 doorsets, constructed in accordance with the specification documented in this global assessment, were to be tested in accordance with BS 476: Part 22: 1987, it is our opinion that they would provide a minimum of 60 minutes integrity and insulation (subject to section 19).

22 Declaration by the Applicant

1. We the undersigned confirm that we have read and comply with obligations placed on us by FTSG Resolution No. 82: 2001.
2. We confirm that the component or element of structure, which is the subject of this assessment, has not to our knowledge been subjected to a fire test to the Standard against which this assessment is being made.
3. We agree to withdraw this assessment from circulation should the component or element of structure be the subject of a fire test to the Standard against which this assessment is being made.
4. We are not aware of any information that could adversely affect the conclusions of this assessment.
5. If we subsequently become aware of any such information we agree to ask the assessing authority to withdraw the assessment.

Signed:

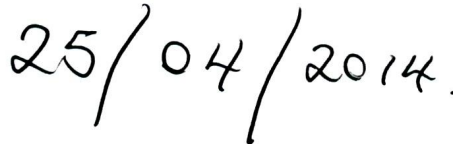

Name:

For and on behalf of: **Pacific Rim Wood Ltd.**



23 Limitations

The following limitations apply to this assessment:

1. This assessment addresses itself solely to the elements and subjects discussed and does not cover any other criteria. All other details not specifically referred to should remain as tested or assessed.
2. This assessment is issued on the basis of test data and information to hand at the time of issue. If contradictory evidence becomes available, BM TRADA reserves the right to withdraw the assessment unconditionally but not retrospectively.
3. This assessment has been carried out in accordance with Fire Test Study Group Resolution No. 82: 2001.
4. Opinions and interpretations expressed herein are outside the scope of UKAS accreditation.
5. This assessment relates only to those aspects of design, materials and construction that influence the performance of the element(s) under fire resistance test conditions. It does not purport to be a complete specification ensuring fitness for purpose and long-term serviceability. It is the responsibility of the client to ensure that the element conforms to recognised good practice in all other respects and that, with the incorporation of the guidance given in this assessment, the element is suitable for its intended purpose.

24 Validity

1. The assessment is initially valid for five years after which time it must be submitted to BM TRADA for technical review.
2. This assessment report is not valid unless it incorporates the declaration given in Section 22 duly signed by the applicant.

Signature:		
Name:	J Godfrey	P N Barker
Title:	Product Assessor	Senior Consultant

The legal validity of this report can only be claimed on presentation of the complete report.

Appendix A

Performance Data

Primary Data

Test Reference	Configuration	Leaf Size (mm)	Test Standard	Integrity (mins)
RF02054 (Palusol)	2No. ULSASD	A: 2070 x 935 x 54 B: 2062 x 935 x 54	BS 476: Part 22: 1987	A: 54* B: 58*
RF02055 (Pyrostrip 500P)	ULSADD	2155 x 935/845 x 54	BS 476: Part 22: 1987	60
RF02117 (Pyrostrip 500P)	2No. ULSASD	A: 2080 x 937 x 54 B: 2380 x 1179 x 54	BS 476: Part 22: 1987	A: 71 B: 61
RF05042 (MDF facings)	A: ULSASD	2080 x 936 x 54	BS 476: Part 22: 1987	A: 63
RF08117 (PU lipping glueline & Pyroplex seals)	B: ULSASD	2040 x 826 x 54	BS 476: Part 22: 1987	B: 62
WF 307381 (Pyroplex seals)	ULSADD	2156 x 936 x 54	BS 476: Part 22: 1987	62

Key:

ULSASD = Unlatched, Single Acting, Single Doorset

ULSADD = Unlatched, Single Acting, Double Doorset

Note:

* The failed single leaf, single acting doorset designs have been assessed through a change in the intumescent specification.

Supplementary Data

Test Reference	Configuration	Leaf Size (mm)	Test Standard	Integrity (mins)
A07051 Rev. B (assessment of Lorient Type 617 seals)	Various	Various	BS 476: Part 22: 1987	60
WF 191350 (Pyrostem)	Fixed sample	1495 x 926 x 54	BS 476: Part 20: 1987	62
WF 313434 (Lorient glazing system RF1)	Indicative	1490 x 1490 x 54	BS 476: Part 20: 1987	74
A11130 Rev. A (CS Group acrovyn & door edge protectors)	Various	Various	BS 476: Part 22: 1987	60
IF11064 (Norsound NOR810S threshold seal)	Indicative	1032 x 926 x 54	BS 476: Part 20: 1987	64
IF12006 (Norsound Vision 60)	Indicative	1090 x 1090 x 54	BS 476: Part 20: 1987	64
IF12027 (Norsound Vision 60)	Indicative	1052 x 1020 x 54	BS 476: Part 20/22: 1987	68
IF12051 (Norsound Vision 60)	Indicative	1300 x 1300 x 70	BS 476: Part 20/22: 1987	79
IF12053 (Norsound Vision 60)	Indicative	1300 x 1300 x 70	BS 476: Part 20/22: 1987	75
IF13077 (Norsound Universal 60)	Indicative	1054 x 1022 x 54	BS 476: Part 22: 1987	64
A12161 (Norsound Vision fanlights & side screens)	Various	Various	BS 476: Part 22: 1987	30 & 60
RF11151 (Norsound NOR910 & NOR920 hardware protection)	LSASD	2040 x 926 x 54	BS 476: Part 20/22: 1987	56*
RF11143 (Pyroplex FG60 glazing system)	ULSADD	2054 x 928 x 54	BS EN 1634-1 & BS EN 1363-1: 1999	61

Note:

* The failure witnessed at 56 minutes was due to a failure at the threshold of the leaf. No further failures were witnessed until 62 minutes. Therefore, BM TRADA have assessed the intumescent hardware protection as suitable for inclusion as it had no bearing on the failure witnessed at 56 minutes.

Appendix B

Proprietary 60 Minute Glazing Systems

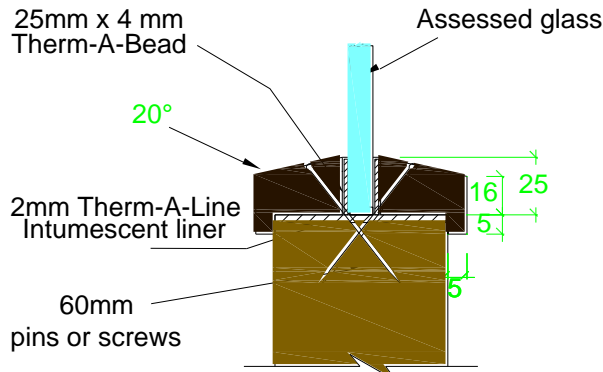

Therm-A-Glaze 60
Intumescent Seals Ltd

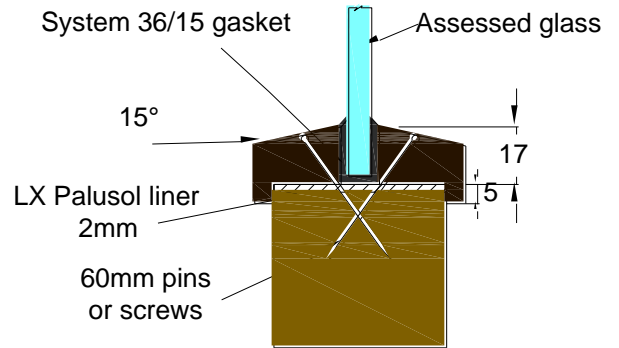

System 36/15
Lorient Polyproducts Ltd

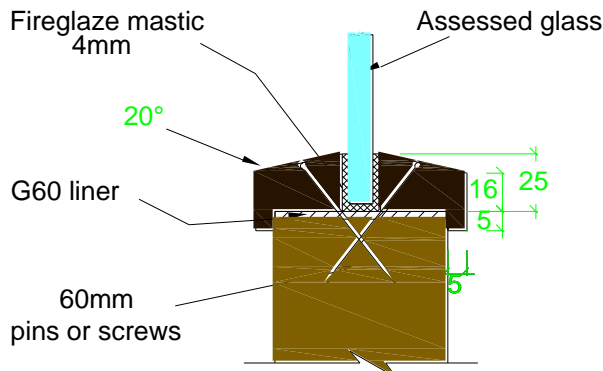

Fireglaze Mastic
Sealmaster Ltd

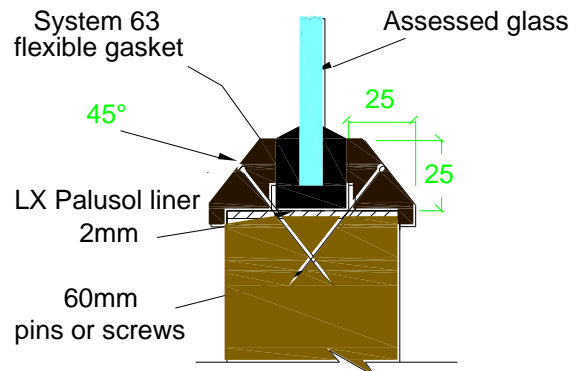

System 63
Lorient Polyproducts Ltd

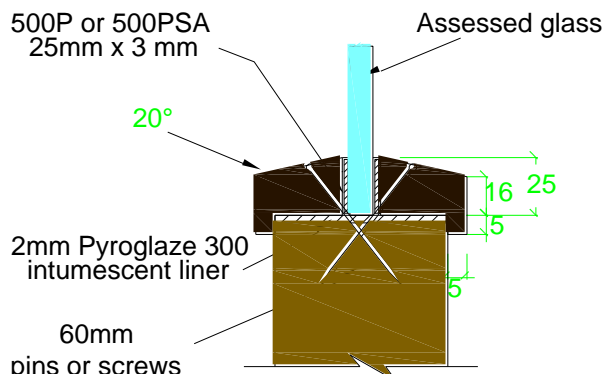

Pyroglaze 60
Mann McGowan Ltd

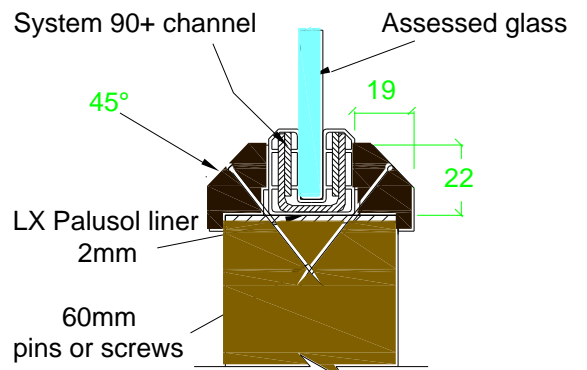

System 90+
Lorient Polyproducts Ltd

The legal validity of this report can only be claimed on presentation of the complete report.

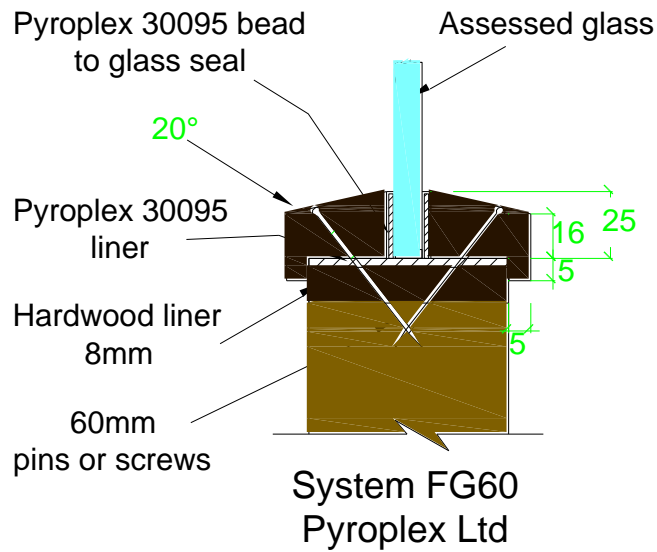

Assessed Square Glazing Bead Profiles

(The following square bead profiles may be used as an alternative to the splayed beads detailed above - refer to section 7 for glazing system and glass restrictions.)

To finish flush with the leaf face

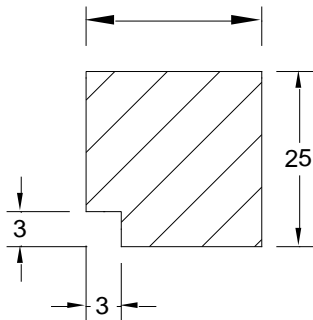

Suited to glass thickness

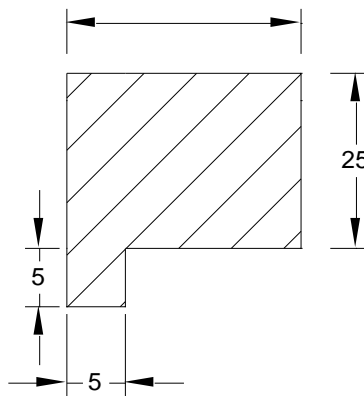

To finish flush with the leaf face

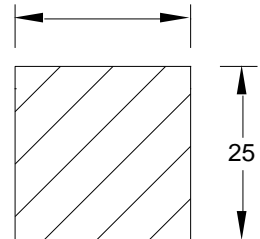

Appendix C

Revisions & Amendments

Revision	BM TRADA Reference	Date	Description
A	A02141	05.03.03	Incorporation of additional test evidence Ref. RF02117 & RF02118 to include mixed hardwood stiles & rails, and increase the leaf sizes in appendix D. Inclusion of MDF facings on LSASD. Filed under FEA/F03047.
B	A03047A	01.02.06	Change of top rail dimension to 100mm.
C	A07039	21.06.07	Update & revalidated for a further 5 year period.
D	A07171	22.08.07	Inclusion of Lorient Type 617 seals & revalidation for 5 years.
E	A09153	15.07.10	Update & revalidate assessment, including PU glue lines for lippings & Pyroplex seals for single leaf doors.
F	A09153	22.07.10	Edit to intumescent gaskets required for flush bolts & top pivots.
G	A11056	05.07.11	Technical review & update of assessment. Evidence from test WF 307381 has been included to permit 2No. 15 x 4mm Pyroplex seals for double doorsets. Assessment revalidated for a further 5 year period.
H	A13248	24.03.14	Inclusion of CS Ltd. acrovyn & door edge protectors, Lorient RF1 glazing system, Pyroplex FG60 glazing system, Norsound Vision 60 & Universal 60 glazing systems, Norsound Vision fanlights & side screens, Norsound NOR 910/NOR 920 intumescent hardware protection, Norsound threshold seals, AGC Flat Glass UK Pyrobel 25, CGI Ltd. Pyroguard 60-23, Pilkington Group Ltd. Pyrostop 60-101 & Pyroclear 60-001, & Pilkington Pyrodur 60-10 for fanlights & side screens.
I	CNA/F14089	22.04.14	Inclusion of updated Norsound Universal drawings, clarification on Norsound intumescent gasket thickness for protecting flush bolts, inclusion of additional Norsound threshold seals

The legal validity of this report can only be claimed on presentation of the complete report.

Appendix D

Data Sheets for:

Pacific Rim Wood Ltd.

Flamebreak 60 Doorsets

60 Minutes Fire Resistance

Pacific Rim Wood Ltd. – Flamebreak 60 Doorsets

Latched & Unlatched, Single & Double Acting, Single Doorsets – Palusol & Type 617

Leaf Sizes	Configuration		Height (mm)		Width (mm)
	LSASD	From:		2062	x
To:			2112	x	935
ULSASD & DASD	From:		2062	x	935
	To:		2062	x	935
Maximum Overpanel Height (mm)		Transomed	2000		
Glazing		Maximum Glazed Area	0.72m ² (see section 7 for details)		
		Approved Systems	See section 7 and appendix B		
Frame Specification		Min. Section (mm)	70 x 32		
		Material	Hardwood		
		Min. Density (kg/m ³)	640		
Intumescent Materials: Lorient Polyproducts Ltd. – Type 617 or PVC encased Palusol Head: 1No. 30 x 4mm seal fitted centrally in the frame reveal. Jamb: 2No. 15 x 4mm seals fitted centrally 10mm apart in the frame reveal. Hardware Protection: See section 11.					

Maximum Door Leaf Size

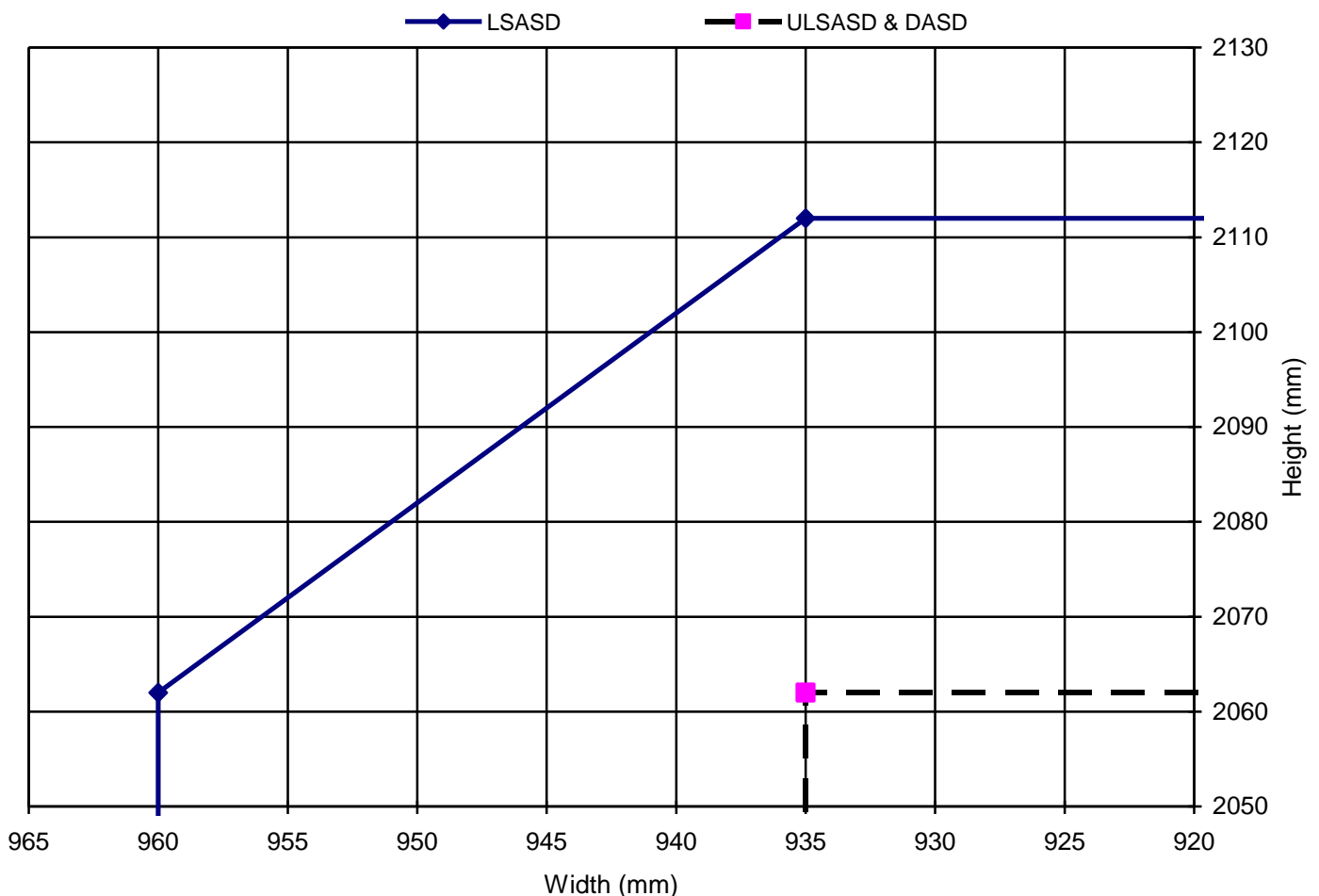

The legal validity of this report can only be claimed on presentation of the complete report.

Pacific Rim Wood Ltd. – Flamebreak 60 Doorsets

Latched & Unlatched, Single & Double Acting, Single Doorsets – Pyrostrip

Leaf Sizes	Configuration		Height (mm)		Width (mm)
	LSASD	From:		2155	x
To:			2305	x	935
ULSASD & DASD	From:		2155	x	985
	To:		2255	x	935
Maximum Overpanel Height (mm)		Transomed	2000		
Glazing		Maximum Glazed Area	0.72m ² (see section 7 for details)		
		Approved Systems	See section 7 and appendix B		
Frame Specification		Min. Section (mm)	70 x 32		
		Material	Hardwood		
		Min. Density (kg/m ³)	640		
Intumescent Materials: Mann McGowan Fabrications Ltd. – Pyrostrip 500P Head: 1No. 30 x 4mm seal fitted centrally in the frame reveal. Jamb: 2No. 15 x 4mm seals fitted centrally 10mm apart in the frame reveal. Hardware Protection: See section 11.					

Maximum Door Leaf Size

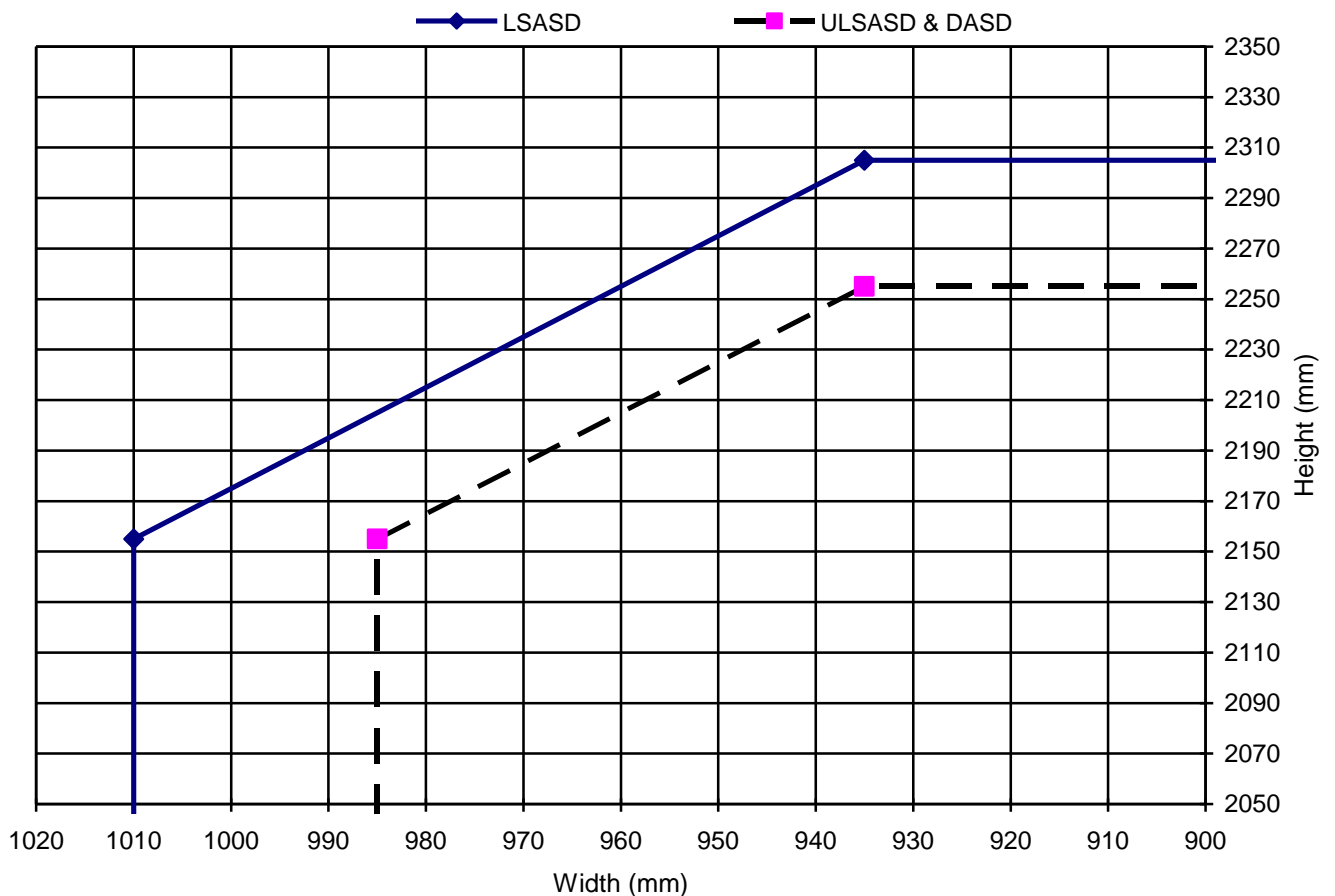

The legal validity of this report can only be claimed on presentation of the complete report.

Pacific Rim Wood Ltd. – Flamebreak 60 Doorsets

Latched & Unlatched, Single & Double Acting, Single Doorsets – Pyroplex Rigid Box Seals

Leaf Sizes	Configuration		Height (mm)		Width (mm)
	LSASD	From:		2040	x
To:			2124	x	826
ULSASD & DASD	From:		2040	x	840
	To:		2074	x	826
Maximum Overpanel Height (mm)		Transomed	2000		
Glazing	Maximum Glazed Area		0.72m ² (see section 7 for details)		
	Approved Systems		See section 7 and appendix B		
Frame Specification	Min. Section (mm)		70 x 32		
	Material		Hardwood		
	Min. Density (kg/m ³)		640		
<p>Intumescent Materials: Pyroplex - PVC encased Pyroplex Rigid Box Seals</p> <p>Head: 2No. 15 x 4mm seals fitted centrally 10mm apart in the frame reveal.</p> <p>Jamb: 2No. 15 x 4mm seals fitted centrally 10mm apart in the frame reveal.</p> <p>Hardware Protection: See section 11.</p>					

Maximum Door Leaf Size

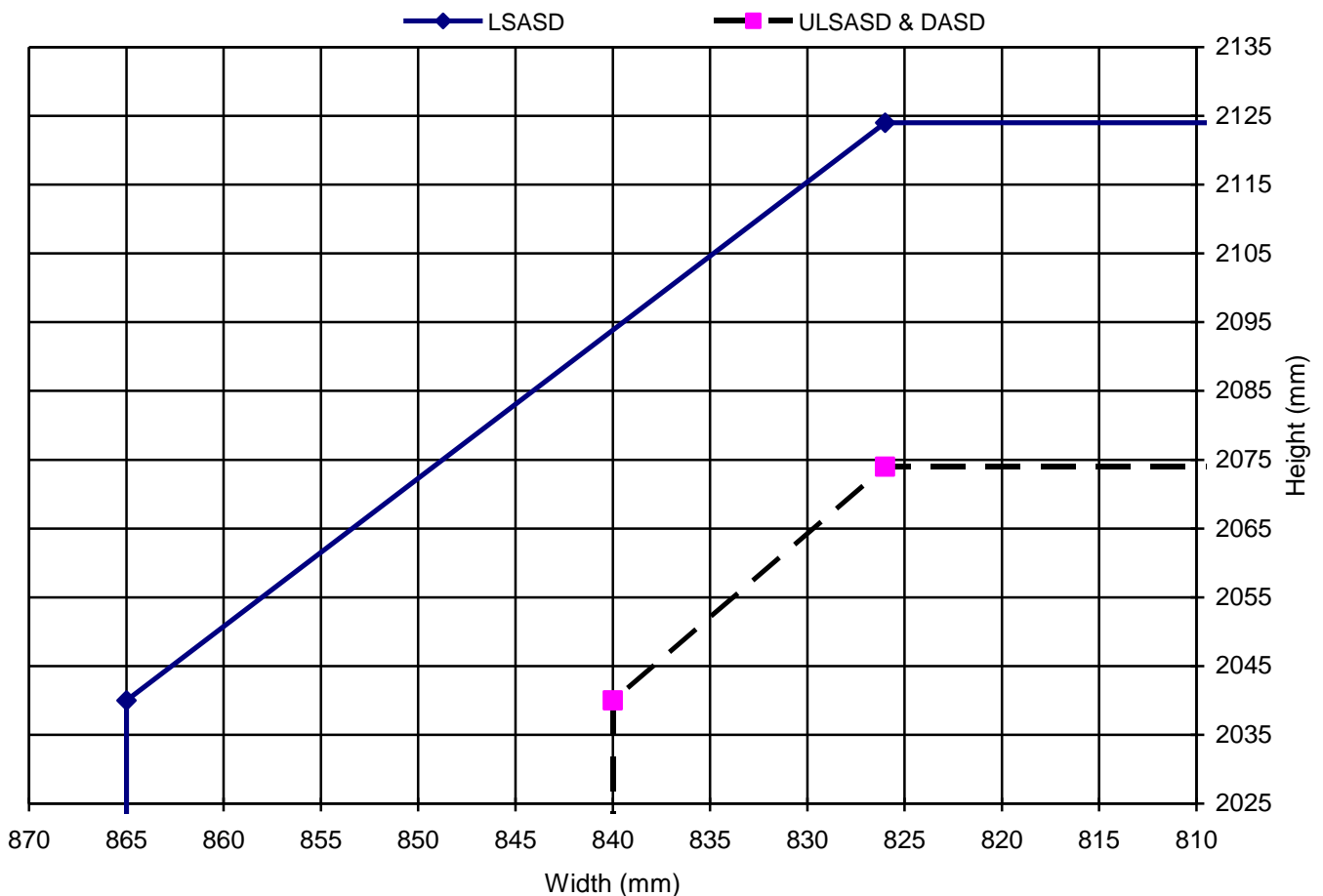

The legal validity of this report can only be claimed on presentation of the complete report.

Pacific Rim Wood Ltd. – Flamebreak 60 Doorsets

Latched & Unlatched, Single & Double Acting, Single Doorsets – Pyroplex Rigid Box Seals

Leaf Sizes	Configuration		Height (mm)		Width (mm)	
	LSASD	From:		2156	x	1019
To:			2323	x	936	
ULSASD & DASD	From:		2156	x	994	
	To:		2273	x	936	
Maximum Overpanel Height (mm)		Transomed	2000			
Glazing	Maximum Glazed Area	0.72m ² (see section 7 for details)				
	Approved Systems	See section 7 and appendix B				
Frame Specification	Min. Section (mm)	70 x 32				
	Material	Hardwood				
	Min. Density (kg/m ³)	640				
Intumescent Materials: Pyroplex - PVC encased Pyroplex Rigid Box Seals						
Head: 2No. 15 x 4mm seals fitted centrally 5mm apart in the frame reveal.						
Jambs: 2No. 15 x 4mm seals fitted centrally 5mm apart in the frame reveal.						
Hardware Protection: See section 11.						

Maximum Door Leaf Size

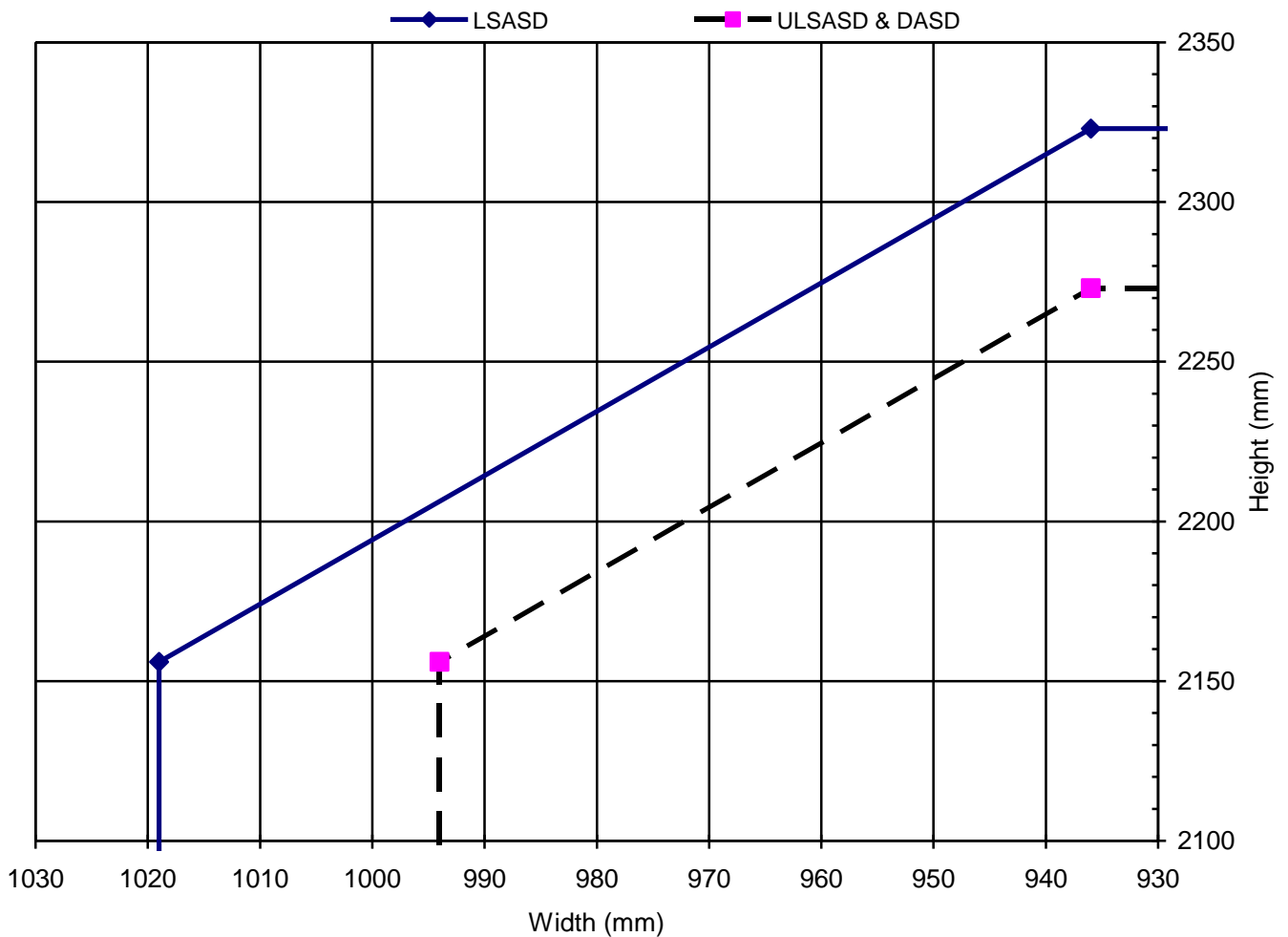

The legal validity of this report can only be claimed on presentation of the complete report.

Pacific Rim Wood Ltd. – Flamebreak 60 Doorsets

Latched & Unlatched, Single & Double Acting, Single Doorsets – Large Leaf Sizes - Pyrostrip

Leaf Sizes	Configuration	From: To:	Height (mm)		Width (mm)	
	LSASD		2380 2450	x x	1213 1179	
	ULSASD & DASD	2380 2400	x x	1188		
				1179		
Maximum Overpanel Height (mm)		Transomed	2000			
Glazing	Maximum Glazed Area		0.72m ² (see section 7 for details)			
	Approved Systems		See section 7 and appendix B			
Frame Specification	Min. Section (mm)		70 x 32			
	Material		Hardwood			
	Min. Density (kg/m ³)		640			
Intumescent Materials: Mann McGowan Fabrications Ltd. – Pyrostrip 500P						
Head: 2No. 15 x 4mm seals fitted centrally 10mm apart in the frame reveal.						
Jambs: 2No. 15 x 4mm seals fitted centrally 10mm apart in the frame reveal.						
Hardware Protection: See section 11.						

Maximum Door Leaf Size

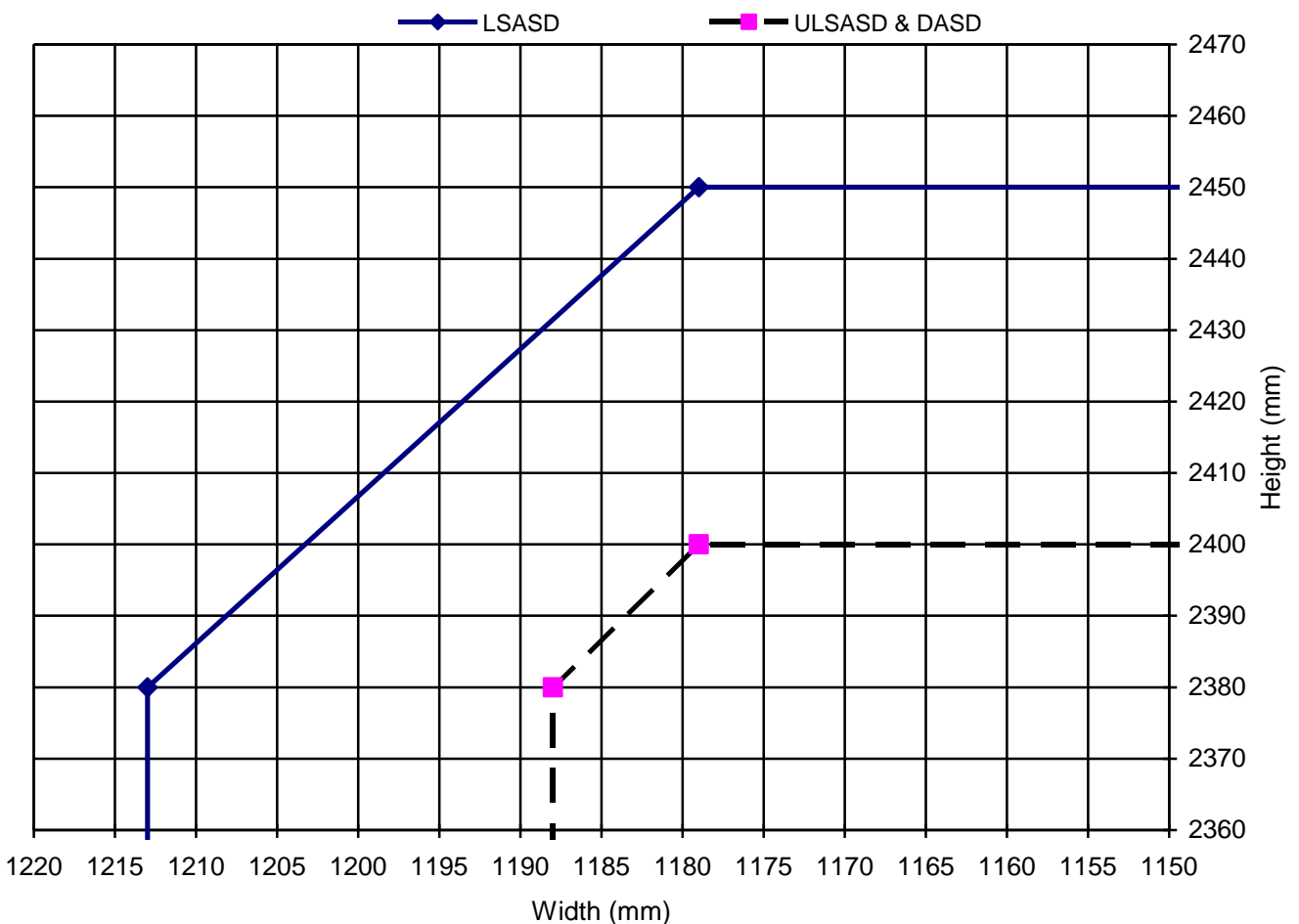

The legal validity of this report can only be claimed on presentation of the complete report.

Pacific Rim Wood Ltd. – Flamebreak 60 Doorsets

Latched & Unlatched, Single & Double Acting, Double Doorsets – Pyroplex Rigid Box Seals

Leaf Sizes	Configuration		Height (mm)		Width (mm)	
			From:	To:	x	
	LSADD	From:	2156	x	969	
		To:	2223	x	936	
	ULSADD & DADD	From:	2156	x	944	
		To:	2173	x	936	
Maximum Overpanel Height (mm)		Transomed	1500			
Glazing		Maximum Glazed Area	0.72m ² (see section 7 for details)			
		Approved Systems	See section 7 and appendix B			
Frame Specification		Min. Section (mm)	70 x 32			
		Material	Hardwood			
		Min. Density (kg/m ³)	640			
<p>Intumescent Materials: Pyroplex - PVC encased Pyroplex Rigid Box Seals</p> <p>Head: 2No. 15 x 4mm seals fitted centrally 5mm apart in the frame reveal.</p> <p>Jamb: 2No. 15 x 4mm seals fitted centrally 5mm apart in the frame reveal.</p> <p>Meeting Edges: 2No. 15 x 4mm seals fitted centrally 5mm apart in one leaf edge.</p> <p>Hardware Protection: See section 11.</p>						

Maximum Door Leaf Size

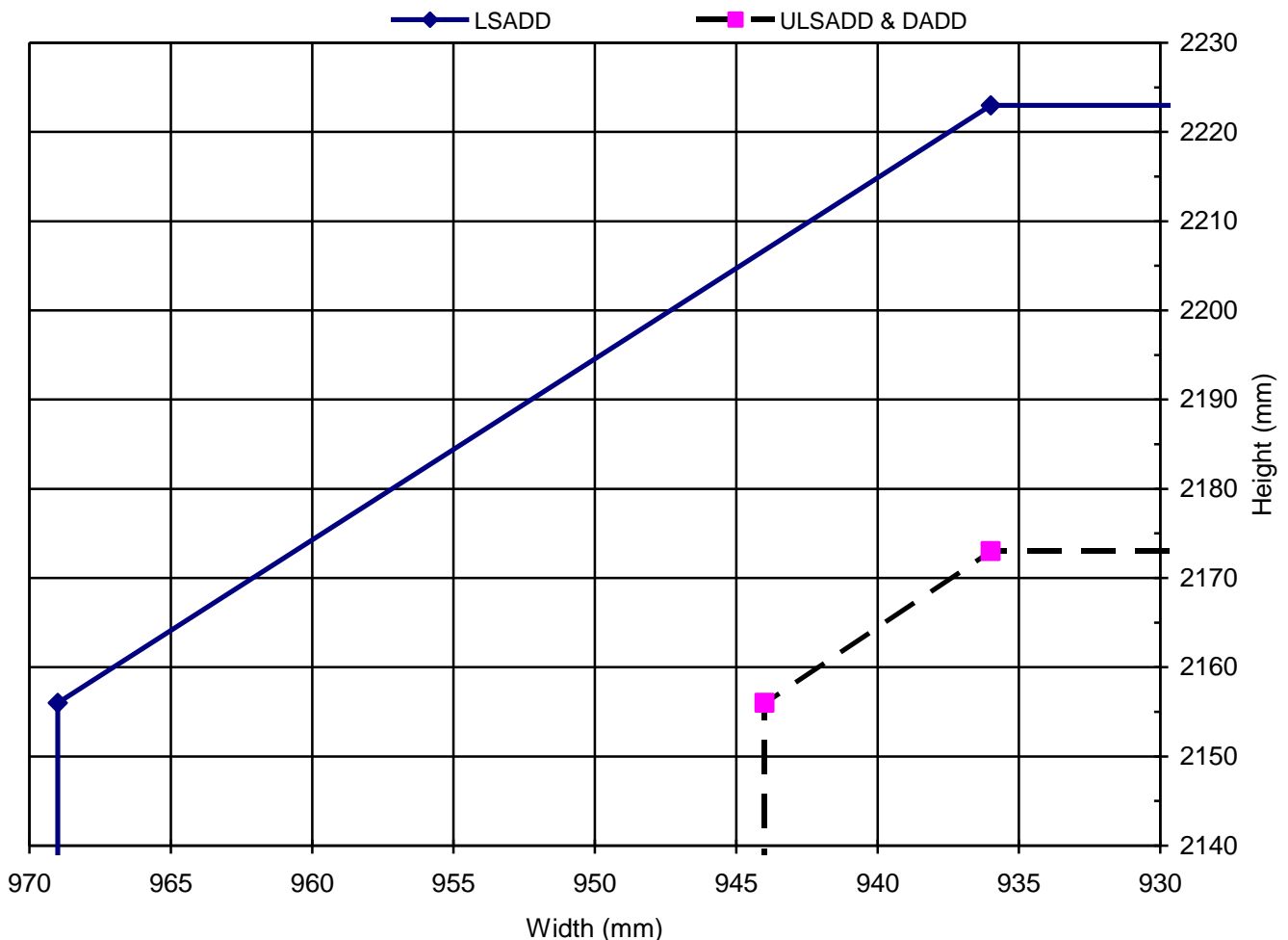

The legal validity of this report can only be claimed on presentation of the complete report.

Pacific Rim Wood Ltd. – Flamebreak 60 Doorsets

Latched & Unlatched, Single & Double Acting, Double Doorsets – Pyrostrip

Leaf Sizes	Configuration		Height (mm)		Width (mm)
	LSADD	From:		2155	x
To:			2205	x	935
ULSADD & DADD	From:		2155	x	935
	To:		2155	x	935
Maximum Overpanel Height (mm)		Transomed	1500		
Glazing	Maximum Glazed Area	0.72m ² (see section 7 for details)			
	Approved Systems	See section 7 and appendix B			
Frame Specification	Min. Section (mm)	70 x 32			
	Material	Hardwood			
	Min. Density (kg/m ³)	640			
Intumescent Materials: Mann McGowan Fabrications Ltd. – Pyrostrip 500P					
Head: 1No. 30 x 4mm seal fitted centrally in the frame reveal.					
Jambs: 2No. 15 x 4mm seals fitted centrally 10mm apart in the frame reveal.					
Meeting Edges: 2No. 15 x 4mm seals fitted centrally 8mm apart in one leaf edge.					
Hardware Protection: See section 11.					

Maximum Door Leaf Size

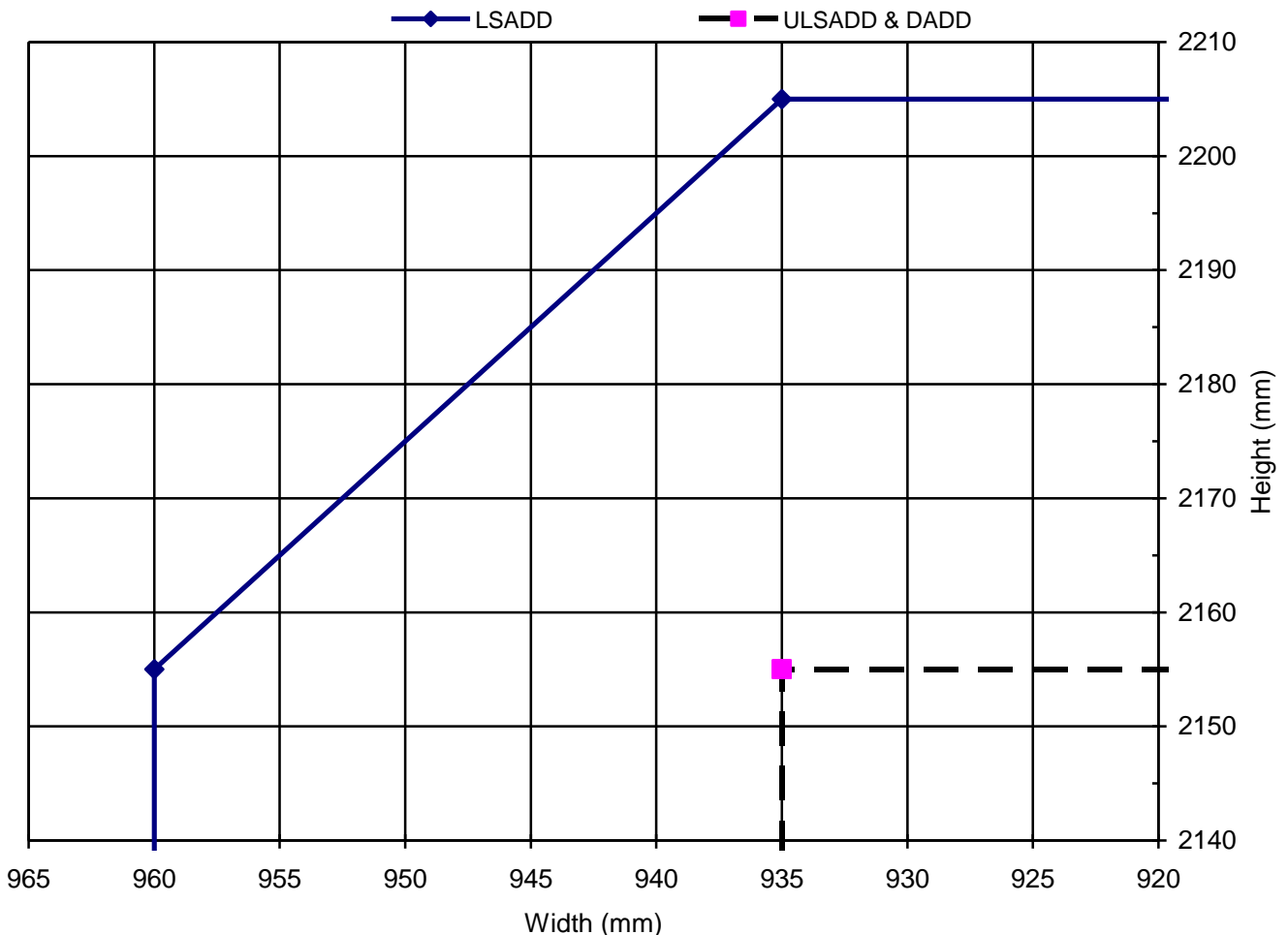

The legal validity of this report can only be claimed on presentation of the complete report.

Pacific Rim Wood Ltd. – Flamebreak 60 Doorsets

Latched & Unlatched, Single & Double Acting, Single Doorsets – CS Edge Protectors/Acrovyn Wrap

Leaf Sizes	Configuration		Height (mm)		Width (mm)
	LSASD	From:		2100	x
To:			2255	x	900
ULSASD & DASD	From:		2100	x	970
	To:		2255	x	900
Maximum Overpanel Height (mm)		Transomed	2000		
Glazing		Maximum Glazed Area	0.72m ² (see section 7 for details)		
		Approved Systems	See section 7 and appendix B		
Frame Specification		Min. Section (mm)	70 x 32		
		Material	Hardwood		
		Min. Density (kg/m ³)	640		
Intumescent Materials: Lorient Polyproducts Ltd. – Type 617 Head: 2No. 15 x 4mm seals fitted 5mm either side of the centreline in the leaf edge or frame reveal. Jams & Overpanels: 2No. 15 x 4mm seals fitted 5mm either side of the centreline in the leaf edge or frame reveal. Hardware Protection: See section 11.					

Maximum Door Leaf Size

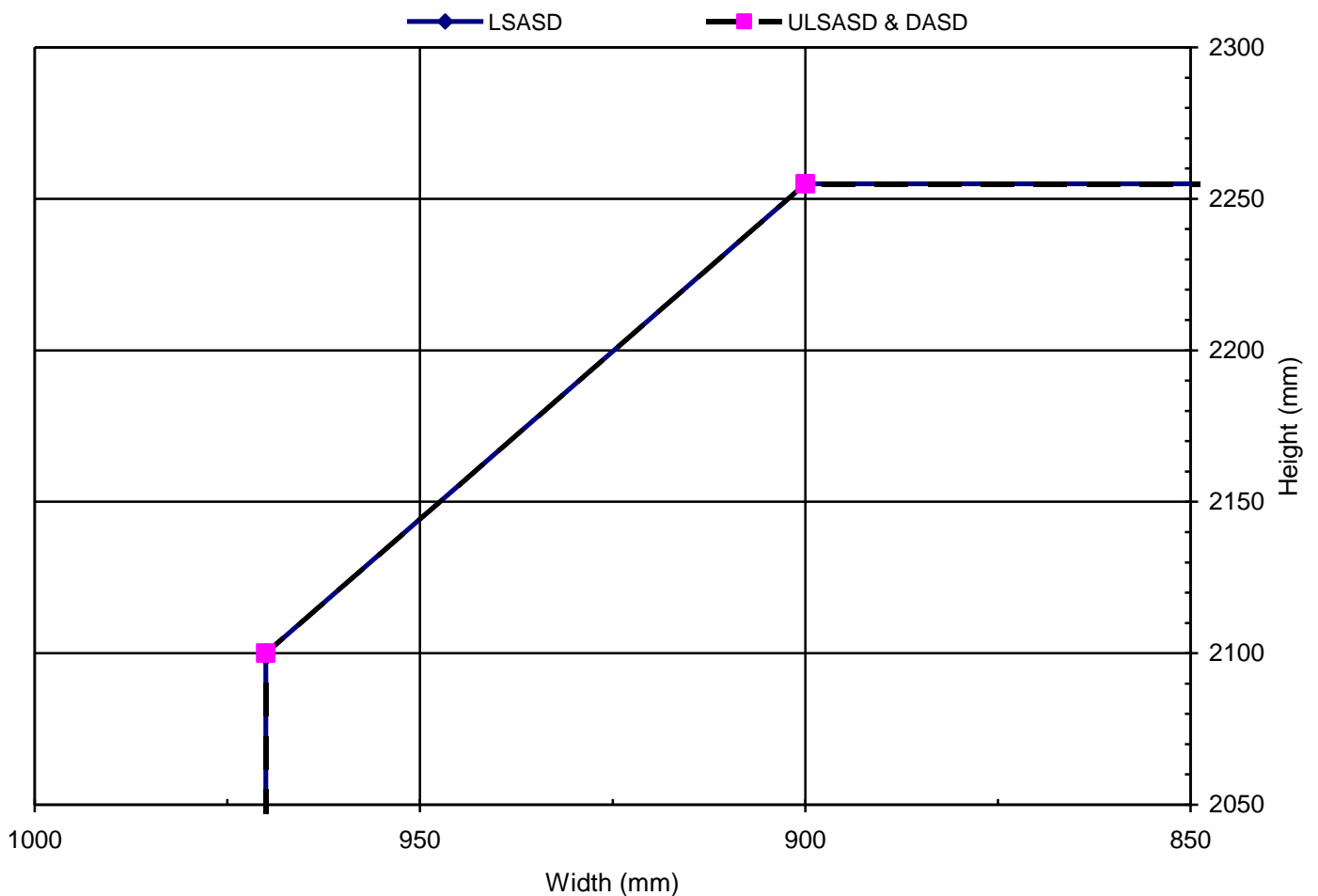

The legal validity of this report can only be claimed on presentation of the complete report.

Pacific Rim Wood Ltd. – Flamebreak 60 Doorsets

Latched & Unlatched, Single & Double Acting, Double Doorsets – CS Edge Protectors/Acrovyn Wrap

Leaf Sizes	Configuration	From: To:	Height (mm)		Width (mm)	
			2100 2205	x x	945 900	945 900
Leaf Sizes	LSADD	From: To:	2100 2205	x x	945 900	945 900
		From: To:	2100 2205	x x	945 900	945 900
Maximum Overpanel Height (mm)		Transomed	1500			
Glazing		Maximum Glazed Area	0.72m ² (see section 7 for details)			
		Approved Systems	See section 7 and appendix B			
Frame Specification		Min. Section (mm)	70 x 32			
		Material	Hardwood			
		Min. Density (kg/m ³)	640			

Intumescent Materials: Lorient Polyproducts Ltd. – Type 617

Head: 2No. 15 x 4mm seals fitted 5mm either side of the centreline in the leaf edge or frame reveal.

Jambes & Overpanels: 2No. 15 x 4mm seals fitted 5mm either side of the centreline in the leaf edge or frame reveal.

Meeting Edges: 1No. 15 x 4mm seal fitted centrally in the meeting edge of both leaves.

Hardware Protection: See section 11.

Maximum Door Leaf Size

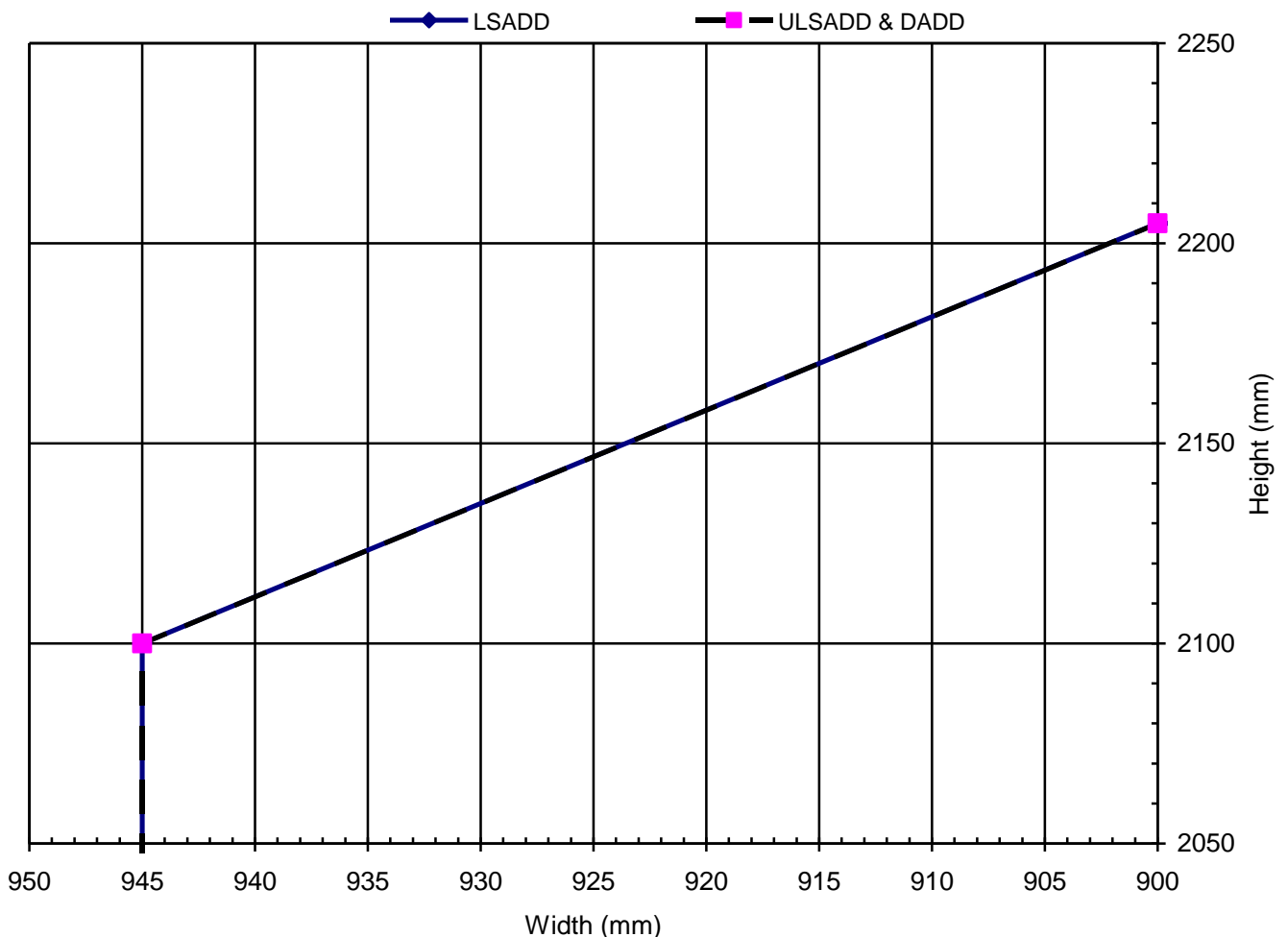

The legal validity of this report can only be claimed on presentation of the complete report.

BM TRADA provides independent certification, testing, inspection, training and technical services around the world. We help customers large and small to prove their business and product credentials and to improve performance and compliance. With an international presence across many industry sectors, we offer a special focus and long history of technical excellence in supply chain certification, product certification and testing, and technical services to the timber, building, fire and furniture industries.



testing@bmtrada.com



bmtradagroup.com



+44 (0) 1494 569800