

Exova Warringtonfire
Chiltern House
Stocking Lane
Hughenden Valley
High Wycombe
Buckinghamshire
HP14 4ND

T: +44 (0) 1494 569 800
F: +44 (0) 1494 564 895
E: globalfire@exova.com
W: www.exova.com



Testing, calibrating, advising.

Title:

Global Fire Resistance Assessment
of Stredor Doorsets

60 Minutes Fire Resistance

Valid From: 19th December 2016

Valid Until: 19th December 2021

WF Report No:

WF377027

Prepared for:

Falcon Panel Products Ltd.

Clock House
Station Approach
Shepperton
Middlesex
TW17 8AN

Exova Warringtonfire – the new name for BM TRADA

On December 1st 2015, Chiltern International Fire Limited (trading as BM TRADA) commenced trading under the name Exova Warringtonfire.

To coincide with this change, our Technical Reports, Test Reports, Product Assessments, company stationery and marketing collateral have been updated to reflect the Exova Warringtonfire branding.

The validity of all documents previously issued by Chiltern International Fire Limited including certificates, test reports and product assessments is unaffected by this change. A letter to this effect is available upon request by e-mailing globalfire@exova.com

About Exova Warringtonfire

Exova Warringtonfire is part of the Exova Group one of the world's leading laboratory-based testing groups, trusted by organisations to test and advise on the safety, quality and performance of their products and operations. Headquartered in Edinburgh, UK, Exova operates 143 laboratories and offices in 32 countries and employs around 4,500 people throughout Europe, the Americas, the Middle East and Asia/Asia Pacific. With over 90 years' experience, Exova specialises in testing across a number of key sectors from health sciences to aerospace, transportation, oil and gas, fire and construction.

Be assured that whilst the name will change, your service provision and primary contacts have not. What will be available to you is a wider team of testing experts and an extended range of testing capabilities including structural steelwork testing, ventilation duct and damper testing, ASTM testing, water mist system testing and smoke toxicity testing and covering additionally both the rail and marine sectors.

If you have any questions, please do not hesitate to contact a member of the team and we will do our best to answer them. We appreciate your business to date and we look forward to working with you in the future.

Kind regards

Exova Warringtonfire

T: +44 (0) 1494 569 800

E: globalfire@exova.com

Contents

	Page No.
1 Introduction	4
2 General Description of Construction.....	4
3 Leaf Sizes	4
4 Configuration.....	5
5 Leaf Size Adjustment	5
6 Overpanels.....	5
7 Glazing.....	6
8 Door Frames	9
9 Lippings	12
10 Leaf Facing Materials	12
11 Adhesives	13
12 Intumescent Materials	13
13 Tested Hardware.....	14
14 Additional & Alternative Hardware	14
15 Structural Opening	17
16 Fixings	17
17 Door Gaps.....	17
18 Sealing to Structural Opening.....	18
19 Insulation	19
20 Smoke Control	19
21 Conclusion	19
22 Declaration by the Applicant.....	20
23 Limitations.....	21
24 Validity	21
Appendix A Performance Data	22
Appendix B 60 Minute Proprietary Glazing Systems	23
Appendix C Revisions	26
Appendix D Data Sheets	27

1 Introduction

This document constitutes a fire resistance assessment relating to Falcon Panel Products Ltd. Stredor timber based door cores, for 60 minute fire resisting doorsets. The assessment uses established extrapolation and interpretation techniques in order to extend the scope of application by determining the limits for the designs, based on the tested constructions and performances obtained. The assessment is an evaluation of the potential fire resistance performance, if the elements were to be tested in accordance with BS 476: Parts 20 & 22: 1987.

2 General Description of Construction

The basic tested construction of the Stredor door design comprises the following.

Element		Material	Dimensions (mm)	Minimum Density (kg/m ³)	
Stiles & rails		None fitted	-	-	
Core	Inner core	Poplar ply*	4 (t)	510*	
	Outer core	Vertically orientated finger-jointed spruce lamels*	17.5 – 22.5 (t) x 28 (w) (nominal individual lamel size)	480*	
Facings		1. MDF	7 (t)	720 ¹	
		2. Plywood	Inner	Cross Grain Poplar: 4 (t)	510 ¹
			Outer	Long Grain Beech: 0.5 (t)	600 ¹
Adhesive	Lippings	PU	-	-	
	Core	Melamine Formaldehyde			
	Facings				
Lippings – all edges		Sapele	6 (t)	640 ²	

Notes: ¹ Stated by client; not verified by laboratory. ² Nominal density.

3 Leaf Sizes

The approval for increased leaf dimensions is based on the test listed in Appendix A and takes into account the margin of over-performance above 60 minutes integrity for the design and the characteristics exhibited during test. Data sheets specifying the maximum approved leaf sizes and graphs showing the permitted gradient between maximum height and width are contained in Appendix D.

Doorsets with reduced dimensions are deemed to be less onerous. Therefore, doors with dimensions that are less than those tested and stated in Appendix D may be manufactured.

4 Configuration

Based on the test evidence listed in Appendix A, this assessment covers the following doorset configurations.

Abbreviation	Description
LSASD & ULSASD	Latched & unlatched, single acting, single doorsets
DASD	Double acting, single doorsets
LSADD & ULSADD	Latched & unlatched, single acting, double doorsets
DADD	Double acting, double doorsets

Unequal leaf double doorsets are covered by this assessment with no restriction on the smaller leaf dimension.

5 Leaf Size Adjustment

The Stredor doorset design referred to in this assessment may be altered as follows.

Element	Reduction
Leaf	The manufactured size of the leaf may be reduced in height or width without restriction providing all edges are re-lipped in accordance with section 9.
Lipping	The lipping dimensions stated in section 9 may be reduced by 20% for fitting purposes.

6 Overpanels

6.1 Solid

Overpanels of the same construction as the door leaves may be used only when separated by a transom. The overpanel must be fully contained within the door frame (see following diagram).

The transom required to separate the leaf heads from the overpanel must be to the same specification as the door frame (see the note under the table in section 8.1).

Door frame joints must utilise one of the following methods: mortice and tenon joints or butt joints (see section 8.2).

Either method requires joints to be tight, with no gaps, and require mechanical fixing with the appropriate size ring shank nails or screws. Butt joints must be additionally bonded with urea formaldehyde.

The overpanels must be fixed by screwing through the rear of the frame with steel screws passing at least 40mm into the centre line of the overpanel. Fixings must be no more than 100mm from each corner and a maximum of 250mm centres in between.

The intumescent seals specified for the jambs in Appendix D must also be fitted to all concealed edges of the overpanel. The seals may be fitted in the overpanel edges or alternatively in the frame reveal. A maximum 2mm gap is permitted between the edge of the overpanel and the frame reveal.

Permitted overpanel heights are as follows.

Configuration	Max. Overpanel Height (mm)
Single doorsets	2000
Double doorsets	1500

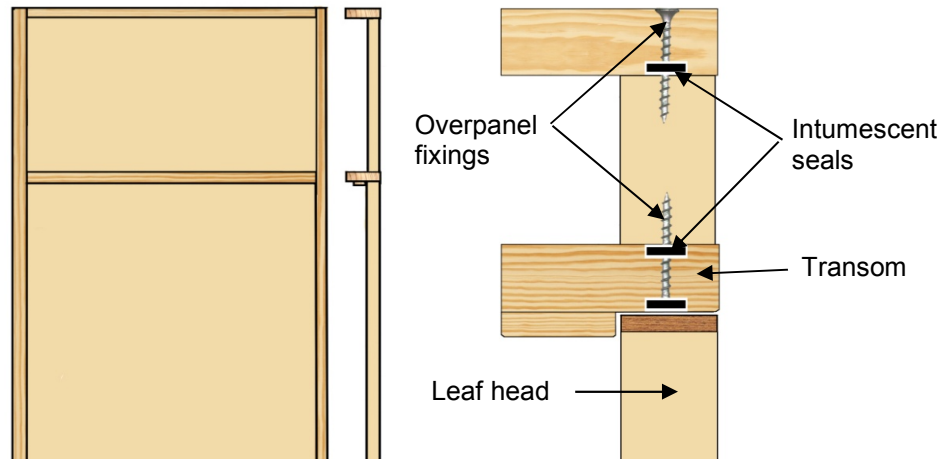

6.2 Glazed Fanlights

Timber frame doorsets including a transom may include a glazed fanlight. The timber frame and glazing beads must be hardwood with a minimum density of 640kg/m³, whilst the frame section for the transom must be a minimum of 70mm x 44mm, the use of Beech (*Fagus sylvatica*) is not permitted. Timber door frame and transom construction must comply with the specification contained in section 8.

The maximum assessed fanlight dimensions are detailed in the table below, subject to the following restriction.

- The glazing system and glass must be able to demonstrate adequate performance when tested as a window or screen in accordance with BS 476: Part 22: 1987, or BS EN 1634-1, at the pane dimensions to be installed.

Screen Element	Configuration	Height (mm)	Width (mm)
Fanlight	Single & double doorsets	≤600	Overall door width

7 Glazing

7.1 General

The testing cited in appendix A, conducted on the Stredor doorset design has successfully demonstrated that the design is capable of tolerating glazed apertures, whilst providing a margin of over-performance. Glazing is therefore acceptable within the following parameters.

The maximum assessed glazed area for all configurations is 1.1m². The glazing system must be one of the following tested proprietary systems.

7.2 Assessed Glazing Systems

The glazing system must be one of the following proprietary tested systems.

Glazing System	Manufacturer	Max. Area (m ²)
1. Therm-A-Glaze 60	Intumescent Seals Ltd.	1.1
2. Fireglaze 60	Sealmaster Ltd.	1.1
3. System 36 Plus	Lorient Polyproducts Ltd.	1.1
4. System 90+	Lorient Polyproducts Ltd.	1.1
5. Pyroglaze 60	Mann McGowan Ltd.	1.1
6. System 63 (Circular Apertures Only)	Lorient Polyproducts Ltd.	1.1
7. ST105GT/ST30x2 liner ¹	Sealed Tight Solutions Ltd	1.1
8. ISL60 Plus	Intumescent Seals Ltd.	0.54
9. Fireglaze Tape	Sealmaster Ltd.	0.54

1. Glazing system 7 may only be used with glass types 3 – 10 in section 7.3
2. Sectional drawings detailing the tested and approved proprietary glazing systems are contained in Appendix B.

7.3 Assessed Glass Products

Assessed glass types are as follows.

Glass Type	Manufacturer	Thickness (mm)	Max. Area (m ²)
1. Pyroshield 2 ¹	Pilkington Group Ltd.	6 & 7	0.715
2. Pyran S	Schott Glass Ltd.	6	1.1
3. Pyrodur 60-10	Pilkington Group Ltd.	10	1.1
4. Pyroguard EW MAXI	Pyroguard UK Ltd.	11	0.58
5. Pyranova 15-S2.0	Schott Glass Ltd.	11	1.1
6. Pyrobelite 12	AGC Flat Glass Europe	12	1.1
7. Pyrodur 60-20	Pilkington Group Ltd.	13	1.1
8. Pyroguard EI 30	Pyroguard UK Ltd.	15	1.1
9. Pyrostop 30-10	Pilkington Group Ltd.	15	1.1
10. Pyrobel 16	AGC Flat Glass Europe	16	1.1

1. See section 7.5 for limitations relating to Pyroshield 2
2. All glass types must be fitted fully in accordance with the manufacturers' tested details/installation requirements, particularly with respect to edge cover and expansion tolerances
3. Glass types 4 and 8 - 10 are fully insulating for 30 minutes in terms of the criteria set out in BS 476: Part 20: 1987.

7.4 Glazing Beads & Installation

Glazing beads must be from hardwood as specified in the following table.

Material	Profile	Application	Min. Density (kg/m ³)
Hardwood	Splayed	All proprietary systems detailed in section 7.2 & shown in Appendix B & all glass types listed in section 7.3	≥640
Hardwood	Square	Proprietary system 1 & 2 as specified in section 7.2 & glass types 3 – 10 listed in section 7.3	≥640

See Appendix B for square and splayed bead profile options. A 6 – 10mm thick square aperture liner is permitted for use with square beads providing it is constructed from hardwood of minimum density 640kg/m³ and glued in position using a UF, PVA or PU type adhesive. The use of Beech (*Fagus sylvatica*) is not permitted.

Glazing beads may be manually fixed using 60mm long x 2mm diameter steel pins or 50mm long No 6 - 8 screws, inserted at 35 - 40° to the vertical at no more than 50mm from each corner and at 150mm maximum centres. Glazing systems 8 & 9 in section 7.2 must use 60mm long No. 6 – 8 screws.

Alternatively, the following 60mm long pin specification has been tested and assessed for steel round, oval and rectangular shaped gun fired pins.

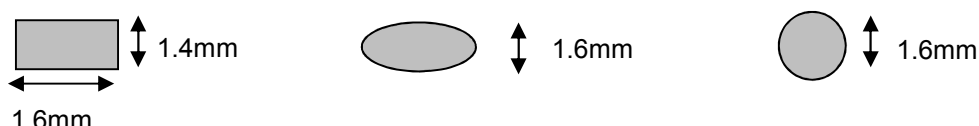

Pins with dimensions less than those stated above are not covered by this assessment.

Glazed openings must not be less than 150mm from any door edge. Multiple apertures are acceptable within the permitted glazed area, with a minimum dimension of 80mm between apertures. Aperture shape is not restricted, providing the glazing system and beads are compatible with that shape.

Timber for glazing beads must be straight grained, joinery quality hardwood, free from knots, splits and checks. The use of Beech (*Fagus sylvatica*) is not permitted.

False timber beads may be bonded to the glass face with an intumescent mastic/silicon, or a 0.5 – 2mm thick self-adhesive intumescent tape/strip of the types shown below; mechanical fixing of the false beads to the leaf framing is not permitted. Suitable glass for this application is restricted to types 3 - 10 in section 7.3.

Glazing System	Manufacturer
1. Therm-A-Strip 30	Intumescent Seals Ltd.
2. Fireglaze 30	Sealmaster Ltd.
3. Firestrip 30	Hodgsons Sealants Ltd.
4. Envirograf Product 77 – G10/10	Intumescent Seals Ltd.
5. Intumescent mastic or silicone tested for glazing applications to BS 476: Part 22: 1987 or BS EN 1634-1	Various

Seals for glazing beads must be a minimum of 10mm wide x 0.5 – 3mm thick. Preformed strip systems 1 – 4 may be self-adhesive and grooved into the rear of the glazing bars.

7.5 Pyroshield 2

The following table details the maximum pane sizes and approved glazing systems permitted for Pyroshield 2:

Glass Type	Glazing System (section 7.3)	Maximum Pane Size* (height x width – mm)	Maximum Area (m ²)
Pyroshield 2	1	1300 x 550	0.715
	4	1300 x 310	0.4

* The heights and widths listed are the maximum single dimensions allowable for an individual pane utilising the relevant glazing system; maximum dimensions may not be increased even if the other dimension for the pane is reduced.

Glazed openings must not be less than 100mm from any door edge. Multiple apertures are acceptable up to the maximum approved area, with a minimum dimension of 80mm between apertures. The aperture shape is not restricted, providing the intumescent material and beads are proven to be compatible with that shape.

Glazing beads must be retained in position with 60mm long steel pins meeting the specification in section 6.3; or 60mm long No. 6 - 8 screws, inserted at 35 - 40° to the vertical at no more than 50mm from each corner and at 150mm maximum centres.

Timber for glazing beads must be straight grained joinery quality, free from knots, splits and checks.

False timber beads must not be applied across the glass face without specific test evidence to justify the system used.

Sectional drawings detailing the tested and approved proprietary glazing systems are contained in appendix B.

8 Door Frames

8.1 Door Frame Construction

Door frames for Stredor doorsets must be constructed to meet the following specification.

Material	Min. Section Size (mm)	Min. Density (kg/m ³)
Hardwood	70 x 32 (excluding the stop)	640

All door frame timber must be straight grained, joinery quality, free from knots, splits and checks. The use of Beech (*Fagus sylvatica*) is not permitted.

A 12mm deep planted stop is adequate for single acting frames whilst double acting frames may be scalloped or square (see diagram below). If frames are square, the maximum radius to the corners of the leaf is 8mm.

Where utilising scalloped frames for double acting doorsets, the groove for the specified intumescent strips must be routed at 90° to the face of the frame and to the correct depth. For typical pivot or floor spring installations, the intumescent strip will be proud of the scalloped profile by a negligible amount, which will not affect performance

Frame joints may be mortice and tenoned, mitred, half lapped or butted and with no gaps (see section 8.2). All jointing methods require mechanical fixing with the appropriate size ring shank nails or screws.

The following diagram depicts the assessed frame profiles and dimensions:

A = Min. 70mm B = Min. 32mm (see table above) C = Min. 12mm
R = Radius from floor spring 8mm radius to create maximum 2mm edge profiling

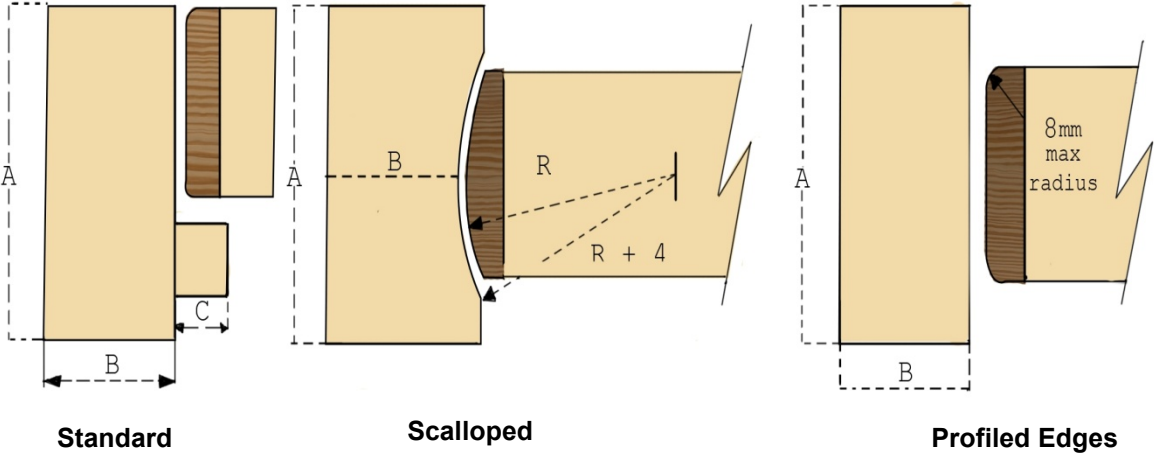

8.2 Door Frame Joints

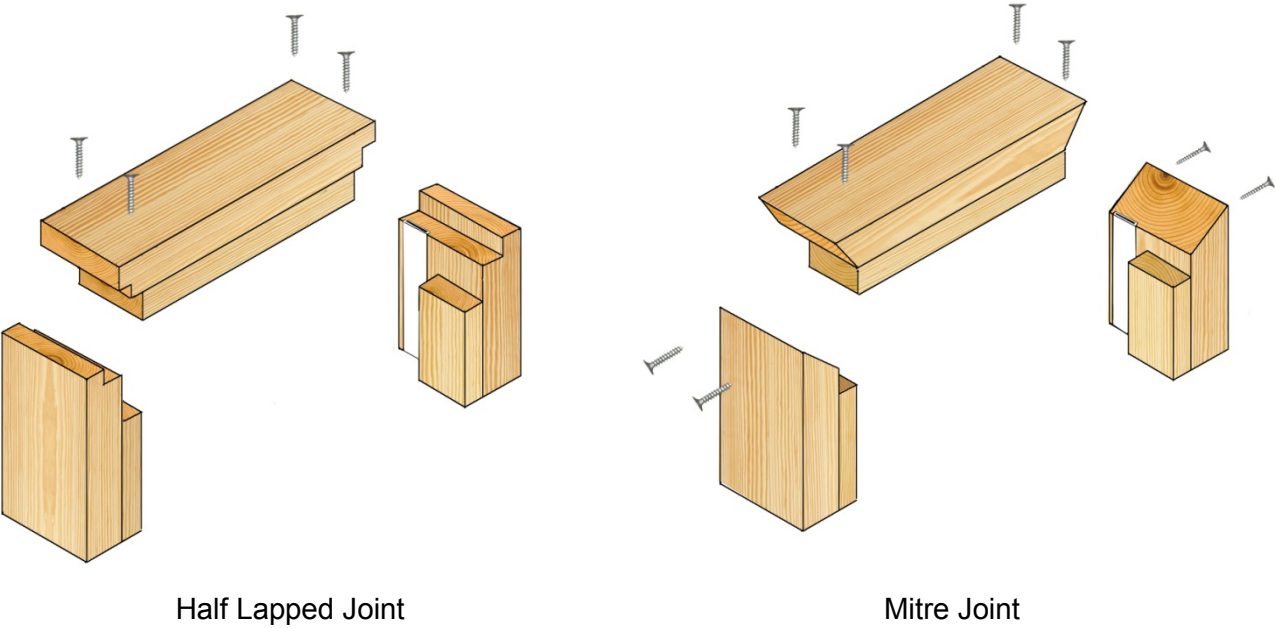

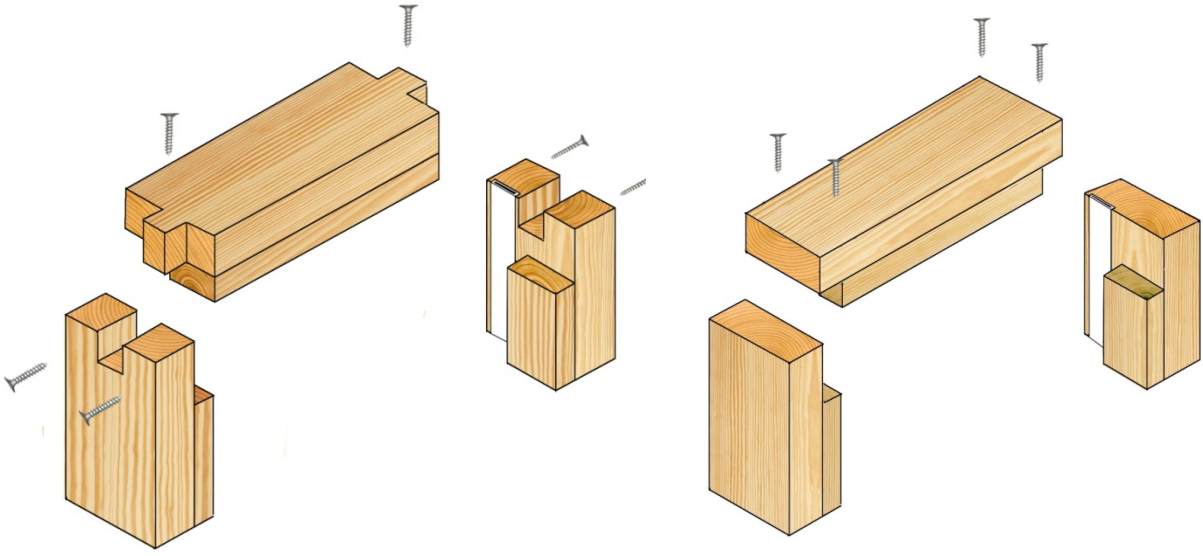

Mortice & Tenon Joint

Butt Joint

For butt jointed frames, the head element must oversail the frame jambs.

8.3 **Door Frame Installation**

The following diagrams indicate acceptable and unacceptable door frame installations:

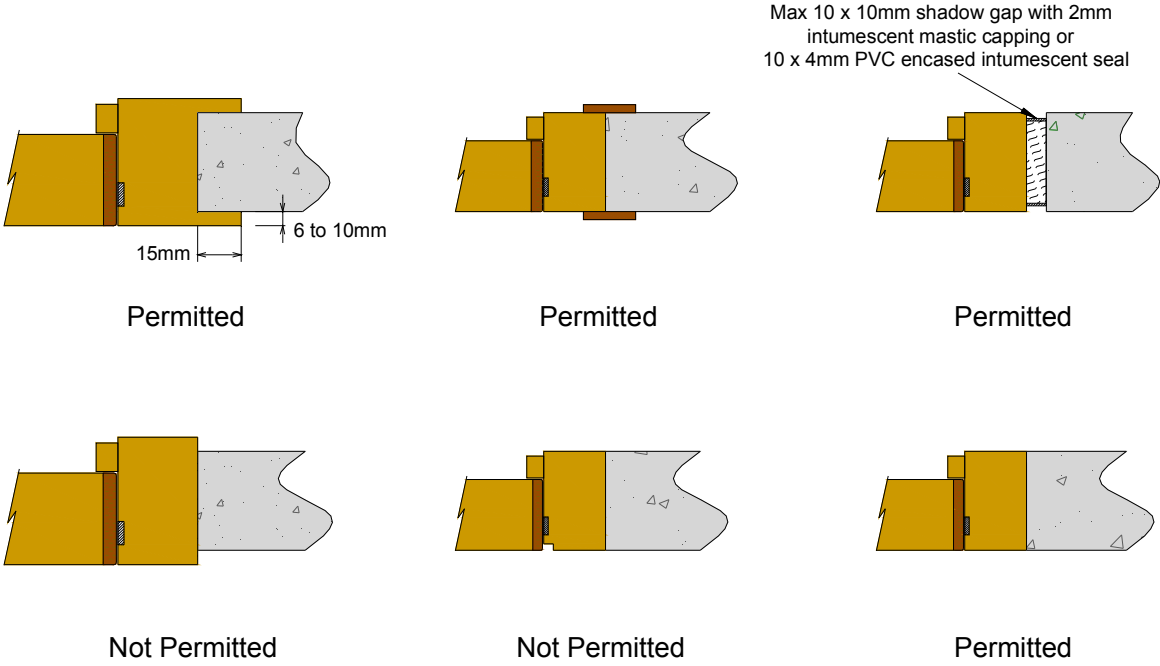

9 Lippings

9.1 General

Stredor 60 doorsets must be lipped in accordance with the following specification.

Material	Size (mm)	Min. Density (kg/m ³)
Hardwood must be straight grained, joinery quality, free from knots, splits and checks.	1. Flat = 6 – 11 thick with a maximum of 2 profiling permitted at corners of lipping (see section 8.1)	640
	2. Rounded = 8 – 13 thick with a radius matching the distance between leaf edge and floor pivot (see section 8.1)	

- Doorsets to this design must be lipped on all leaf edges
- Lippings must not conceal intumescent materials
- A 2.5° chamfer is permitted to the lipping at the leading edge of leaves providing the door gaps meet the requirements of section 17
- Rounded lippings must only be fitted to the hanging edges of door leaves
- The use of Beech (*Fagus sylvatica*) is not permitted.

10 Leaf Facing Materials

10.1 General

The primary tested facing material within test FEP/F16174 for the Stredor 60 doorset design was nominally 7mm thick MDF and within test WF369636 nominally 4.5mm thick Plywood. At this thickness facings are considered to have a structural effect and therefore alternative materials are not permitted. The finished leaf thickness must be 54mm.

10.2 Decorative & Protective Facings

The following additional facing materials are permitted for this door design since they would degrade rapidly under test conditions without significant effect.

Facing Material	Maximum Permitted Thickness (mm)
Paint	0.5
Timber veneers	2
Plastic & resin laminates	2
Cellulosic Foils	0.4

1. Metallic facings are not permitted except for push plates and kick plates
2. The door leaf thickness may be reduced by a total maximum of 0.6mm to each face (a maximum of 1.2mm in total) for calibration purposes, only in order to accommodate one of the additional facings shown in the table above
3. Materials must not conceal intumescent strips
4. PVC/plastic laminates must not be applied to the edges of leaves.

11 Adhesives

The following adhesives must be used in construction.

Element	Product
Lippings	Polyurethane
Core	Melamine formaldehyde
Facings	

12 Intumescent Materials





12.1 General

Based on FEP/F16174 & WF374929, the intumescent materials tested and assessed for the Stredor 60 doorset design are as follows.

Application	Location	Product/Manufacturer
Edge seals	Fitted in the frame jambs or leaf edges	1. Pyroplex Ref: 8700 – Pyroplex Ltd. 2. ST1504 – Sealed Tight Solutions Ltd
Hinges	Under all hinge blades	1. Pyroplex graphite 2mm – Pyroplex Ltd. 2. STS graphite 1mm thick - Sealed Tight Solutions Ltd
Lock/latches	Under latch forend & keep only	
	Under latch forend & keep & encasing latch body	
Top pivots & flush bolts	Lining all sides of the mortices & under flush bolt keep in frame head	

The seal specification for each doorset configuration is contained in Appendix D.

Intumescent seals may be provided with or without pile or elastomeric fins in order to provide additional performance i.e. smoke or acoustic control. Seals may be installed with the additional features, it is beyond the remit of this assessment to discuss likely acoustic or cold smoke control performance. See table below for a selection of available Pyroplex seal types. Other variations are available and are considered acceptable as per the above.

Pyroplex Seal Details		 Pile only	 Twin flipper	 Triple flipper
Description	Fire Only	Fire and Smoke	Twin Flipper	Triple Flipper
15mm x 4mm Ref:	8700	8712	30175	30141
20mm x 4mm Ref:	8600	8612	30176	30148

13 Tested Hardware

The following hardware has been successfully incorporated in the tests on this design.

Element	Product Reference	Dimensions (mm)
Hinges	Smith & Locke – Bearing butt type hinges	100 x 40 (blade size)
	Eurospec bearing - Bearing butt type hinges	101 x 30 (blade size)
Closers	Arrone AR1500 overhead face-fixed type closer	220 x 60 (footprint)
Latches/locks	Elect Brass Tubular steel mortice latch	60 x 32 (forend) 60 x 33 (keep size)
	Zoo Hardware mortice latch	230 x 22 (forend) 180 x 25 (keep size)
Furniture	Smith & Locke lever type handle ref: 2812H	Ø50 (rose size)
	Zoo Hardware steel lever type handle	Ø52 (rose size)
Shoot Bolts	Exova shop purchased stock	100 x 22 (footprint)
		45 x 22 (keep size)
		205 x 22 (footprint) 42 x 15 (keep size)

14 Additional & Alternative Hardware

14.1 General

The following section details the permitted scope and constraints for fitting hardware to this door design.

The following items of hardware must also bear the CE Mark:

- Latches & Locks: Standard EN 12209
- Single Axis Hinges: Standard EN 1935
- Controlled Door Closing Devices: Standard EN 1154
- Panic Exit Hardware: Standard EN 1125.

14.2 Latches & Locks

Latches and locks must either be as tested, or alternatively components with the following specification are acceptable.

Element	Specification
Maximum forend & strike plate dimensions	235mm high by 22mm wide by 4mm thick
Maximum body dimensions	180mm high by 100mm wide by 18mm thick
Intumescent protection	See section 12
Materials	All parts essential to the locking/latching action (including the latch bolt, forend & strike) to be steel or brass (with a melting point $\geq 800^{\circ}\text{C}$)
Location	Between 750 – 1200mm from the threshold

14.3 Automatic Closing

Automatic closing devices must either be as tested or components of equal specification that have demonstrated contribution to the required integrity performance of this type of 30 minute doorset design, when tested to BS 476: Part 22: 1987 or BS EN 1634-1.

Top pivots to floor spring assemblies must be protected with 2mm thick intumescent gasket (see section 12) or alternatively the manufacturers tested intumescent pack.

Note: It is not permitted to fit concealed closers to this door design.

14.4 Pull Handles

Handles may be surface-fixed or bolted through the door leaf, providing they are steel or brass and the length is limited to 1200mm between the fixing points. If through-fixed, there must be no more than 1mm clearance between the hole and stud.

14.5 Hinges

Stredor door leaves must be hung on a minimum of 3 hinges. Leaves over 2400mm high must fit 4 hinges. Hinges with the following specification are acceptable.

Element		Specification	
Blade height		90 – 120mm	
Blade width (excluding knuckle)		30 – 35mm	
Blade thickness		2.5 – 4mm	
Fixings		Minimum of 4No. 30 long No. 8 or No. 10 steel wood screws per blade	
Materials		Steel or stainless steel or brass (melting point $\geq 800^{\circ}\text{C}$)	
Hinge positions	Leaf dimensions <2400mm	Top	150 – 200mm from head of leaf to top of hinge
		2 nd	Minimum 200mm from top hinge OR equally spaced between top & bottom hinges
		Bottom	150 – 300mm from foot of leaf to bottom of hinge
	Leaf dimensions >2400mm	Top	150 – 200mm from head of leaf to top of hinge
		2 nd & 3 rd	Minimum 200mm from top hinge to equispaced between top & bottom hinges
		Bottom	150 – 300mm from foot of leaf to bottom of hinge
Intumescent protection		See section 12	

14.6 Push Plates/Kick Plates

Face-fixed hardware such as push plates and kick plates may be fitted to the doorsets provided that their fitting requires the removal of no part of the door leaf. These items of hardware are permitted up to a maximum of 20% of the door leaf area if mechanically fixed and a maximum of 30% if bonded with a thermo-softening contact adhesive. Plates must not return around the door leaf edges.

14.7 **Panic Hardware**

Panic hardware may be fitted, provided that its installation does not require the removal of any timber from the leaf, stop or frame reveal and it in no way interferes with the self-closing action of the door leaf.

14.8 **Door Security Viewers**

Door security viewers with brass or steel bodies of a diameter less than or equal to 15mm may be used provided that the through-hole is bored tight to the case of the viewer (maximum tolerance +1mm). Lenses must be glass and the item must be bedded in to a tested intumescent mastic.

14.9 **Flush Bolts**

Flush bolts may be incorporated centrally into the top and bottom of one meeting edge, providing the following maximum dimensions are not exceeded and the components are fitted opposite the edge fitted with intumescent strips:

- 200mm long x 22mm deep x 22mm wide

Flush bolts must be steel or brass and the mortice must be as tight to the mechanism as is compatible with its operation. All edges of the mortice must be protected with intumescent gaskets as specified in section 12. Alternatively the hardware manufacturers tested gaskets may be used. See diagram below for example of intumescent protection to flush bolt:

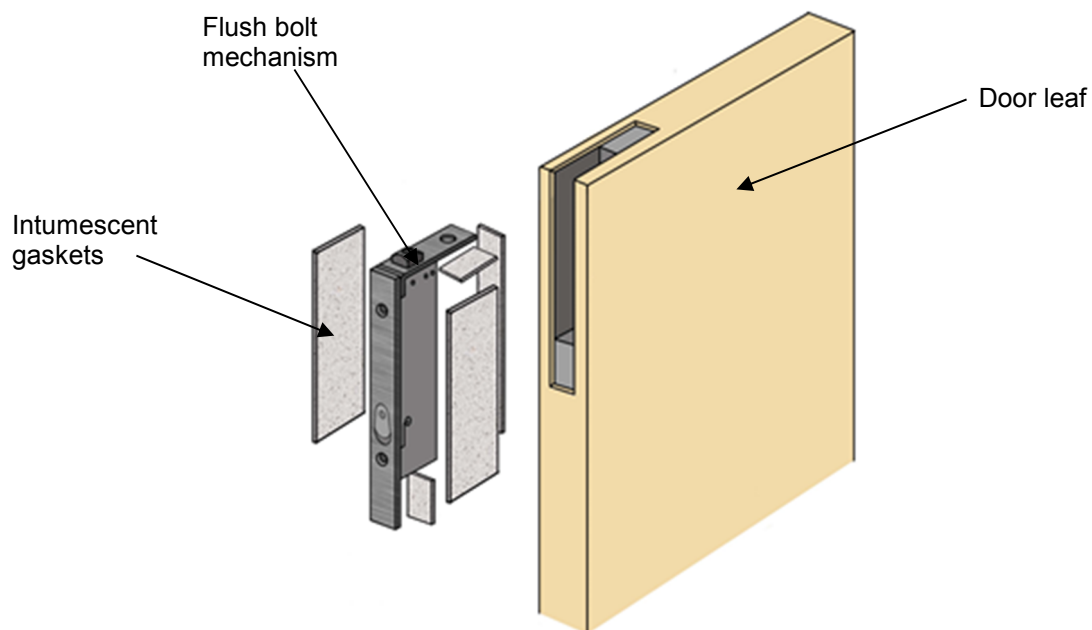

14.10 **Environmental Seals**

Flame retardant acoustic, weather and dust seals (e.g. Norsound 710, Lorient IS1212, IS1511, IS7025, IS7060, Reddiplex Ltd 10623, 9946, 9927, 9945) may be fitted to this doorset design without compromising the performance, providing their fitting does not interfere with the activation of the intumescent seals or hinder the self-closing function of the leaves.

14.11 Letter Boxes/Plates

Letter boxes/plates may be fitted providing the product can demonstrate contribution to the required performance of this type of 60 minute doorset design, when tested to BS 476: Part 22: 1987 or BS EN 1634-1, when installed within a timber based doorset of comparable thickness. Products may be fitted up to 1200mm from floor level and not closer than 100mm to any leaf edge.

14.12 Threshold Seals

The following types of automatic threshold drop seals may be recessed in to the bottom edge of leaves to this design without compromising the performance.

Manufacturer	Product
Lorient Polyproducts Ltd.	LAS8001Si
Pemko	411 – AR
Raven	RP8Si
Athmer	Schall-Ex Duo L-15
Norsound Ltd.	NOR810, NOR810S, NOR810dB+
Reddiplex Ltd	Reddiplex IDD Threshold

14.13 Air Transfer Grilles

Air transfer grilles may be fitted providing the product has suitable test evidence to BS 476: Part 22: 1987 or BS EN 1634-1, that demonstrates a minimum 60 minutes integrity performance when installed within a timber based doorset of comparable thickness. Margins to the leaf edges will remain as detailed for glazing and the position of the unit will be dictated by the pressure regime tested in the proving evidence (normally below mid-height). The area occupied by the air transfer grille must not exceed 0.2m² and must be deducted from the area of glazing, if both elements are fitted.

15 Structural Opening

The supporting construction must provide the required level of fire resistance designated for the doorset design and be a suitable medium to permit adequate fixity.

16 Fixings

The frame jambs are to be fixed to the supporting construction using steel fixings at 600mm maximum centres. The fixings must be of the appropriate type for the supporting construction and must penetrate to a minimum depth of 40mm. It is not necessary to fix the frame head, although packers must be inserted. Craylon Ltd Craylon Blue 60 packers have been successfully tested for this application.

17 Door Gaps

For fire resistance performance, door edge gaps and alignment tolerances must fall within the range shown in the following table.

Location	Dimensions
Door edge gaps	A minimum of 2mm and a maximum of 4mm
Alignment tolerances	Leaves must not be proud of each other or from the door frame by more than 1mm
Threshold	10mm between bottom of leaf and top of floor covering

18 Sealing to Structural Opening

The door frame to structural opening gap must be protected using one of the following methods.

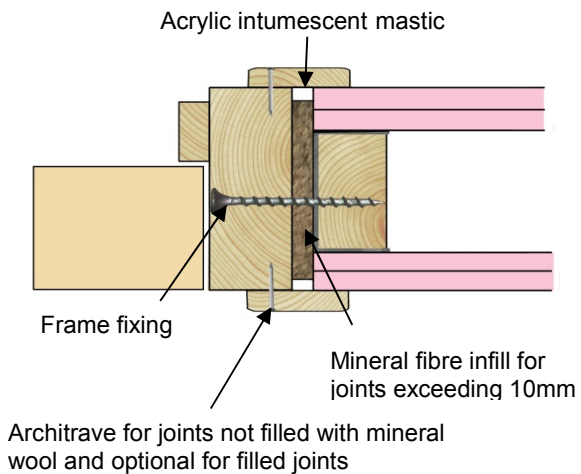
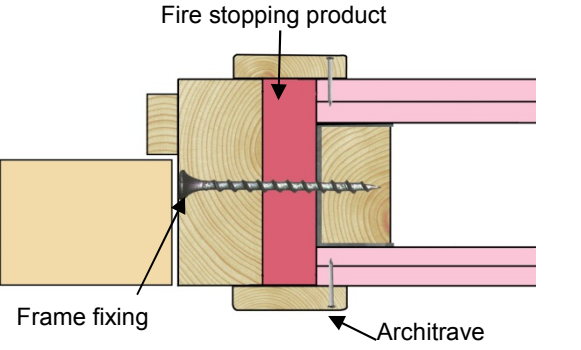
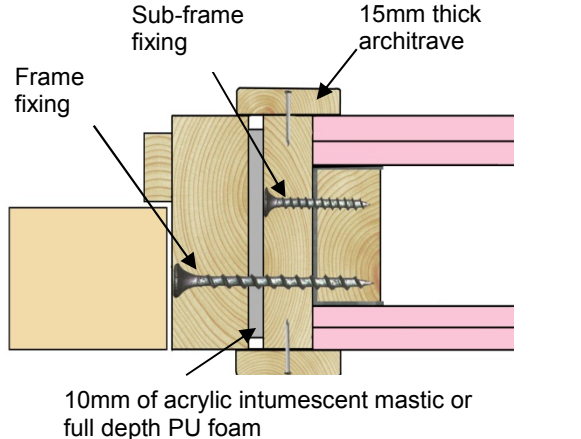
<p>1. Gaps up to 10mm must be sealed on both sides with a 10mm depth of acrylic intumescent mastic, fire tested for this application to BS 476: Part 22: 1987 or BS EN 1634-1. Joint must be fitted with 15mm thick architraves overlapping at least 15mm each side.</p>	 <p>Acrylic intumescent mastic</p> <p>Frame fixing</p> <p>Mineral fibre infill for joints exceeding 10mm</p> <p>Architrave for joints not filled with mineral wool and optional for filled joints</p>
<p>2. Gaps between 10mm and 20mm must be tightly packed with mineral fibre capped on both sides with a 10mm depth of acrylic intumescent mastic, fire tested for this application to BS 476: Part 22: 1987 or BS EN 1634-1. Architraves are optional.</p>	 <p>Fire stopping product</p> <p>Frame fixing</p> <p>Architrave</p>
<p>3. Gaps up to 20mm filled with proprietary fire stopping product (e.g. expanding PU foam or preformed compressible intumescent foam). Products must be tested for this application to BS 476: Part 22: 1987 or BS EN 1634-1. Joint must be fitted with 15mm thick architraves overlapping at least 15mm each side. Craylon Ltd Blue60 expanding foam has been successfully tested for this application.</p>	 <p>Sub-frame fixing</p> <p>15mm thick architrave</p> <p>Frame fixing</p> <p>10mm of acrylic intumescent mastic or full depth PU foam</p>
<p>4. Timber based or non-combustible sub-frame up to 50mm thick, with gaps up to 10mm between the components filled on both sides with 10mm depth of acrylic intumescent mastic or full depth expanding PU foam, fire tested for this application to BS 476: Part 22: 1987 or BS EN 1634-1. Joint must be fitted with 15mm thick architraves overlapping at least 15mm each side.</p>	

Guidance for various methods of sealing the frame to structural opening gap is also given in BS 8214: 2008, "Code of practice for fire door assemblies", which may be referred to where appropriate.

Drawings are representative of doorset installation only; actual installations must be as the text within this document specifies.

19 Insulation

Insulation performance may be claimed for a doorset to this design meeting the following.

Type	Details
Partially insulating	Doorsets incorporating up to 20% of non-insulating glazing
Fully insulating	Unglazed doorsets

20 Smoke Control

20.1 General

If the doorset design is required to provide a smoke control function to comply with Building Regulations, in the absence of a suitable pressurisation system, the doorset must meet one of the following criteria:

- (a) have a leakage rate not exceeding $3\text{m}^3/\text{m}/\text{hour}$ (head and jambs only) when tested at 25Pa under BS 476 *Fire tests on building materials and structures*, Section 31.1 – *Methods for measuring smoke penetration through doorsets and shutter assemblies, Method of measurement under ambient temperature conditions*; or
- (b) meet the additional classification requirement of Sa when tested to BS EN 1634-3: 2004 – *Fire resistance tests for door and shutter assemblies, Part 3 – Smoke control doors*.

Smoke seals or combined intumescent/smoke seals that are fitted to the door to achieve the performance requirements specified above, must have been tested in accordance with the associated test method. Providing the smoke seals, any interruptions, door gaps, and the type/configuration of the doorset are consistent with the detail tested, the doorset will comply with current smoke control legislation under Approved Document B; and a suffix 'S' or 'Sa', as appropriate, may be added to the designation. Any other components installed where smoke leakage may occur must also be taken into account.

20.2 Further Considerations

Note that there is other guidance available, including BS EN 9999-2008 – *Code of practice for fire safety in the design, management and use of buildings*, which may impose different or additional requirements, such as consideration of the gap between door leaf and threshold.

Responsibility for the appropriate smoke sealing specification and performance of the doors should be agreed between the relevant parties (i.e. specifier, manufacturer, contractor) prior to commencing manufacture and/or installation.

21 Conclusion

If the Falcon Panel Products Ltd. Stredor 60 doorset design, constructed in accordance with the specifications documented in this Global Assessment, were to be tested in the appropriate configuration in accordance with BS 476: Part 22: 1987, it is our opinion that it would provide a minimum of 60 minutes integrity and insulation (subject to section 19).

22 Declaration by the Applicant

1. We the undersigned confirm that we have read and comply with obligations placed on us by FTSG Resolution No. 82: 2001.
2. We confirm that the component or element of structure, which is the subject of this assessment, has not to our knowledge been subjected to a fire test to the Standard against which this assessment is being made.
3. We agree to withdraw this assessment from circulation should the component or element of structure be the subject of a fire test to the Standard against which this assessment is being made.
4. We are not aware of any information that could adversely affect the conclusions of this assessment.
5. If we subsequently become aware of any such information we agree to ask the assessing authority to withdraw the assessment.

Signed:

Name:

For and on behalf of: Falcon Panel Products Ltd.

23 Limitations

The following limitations apply to this assessment:

1. This assessment addresses itself solely to the elements and subjects discussed and does not cover any other criteria. All other details not specifically referred to should remain as tested or assessed.
2. This assessment is issued on the basis of test data and information to hand at the time of issue. If contradictory evidence becomes available, Exova Warringtonfire reserves the right to withdraw the assessment unconditionally but not retrospectively.
3. This assessment has been carried out in accordance with Fire Test Study Group Resolution No. 82: 2001.
4. Opinions and interpretations expressed herein are outside the scope of UKAS accreditation.
5. This assessment relates only to those aspects of design, materials and construction that influence the performance of the element(s) under fire resistance test conditions. It does not purport to be a complete specification ensuring fitness for purpose and long-term serviceability. It is the responsibility of the client to ensure that the element conforms to recognised good practice in all other respects and that, with the incorporation of the guidance given in this assessment, the element is suitable for its intended purpose.

24 Validity

1. The assessment is valid 5 years from the date of issue, after which time it must be submitted to Exova Warringtonfire for re-appraisal.
2. This assessment report is not valid unless it incorporates the declaration given in Section 22 duly signed by the applicant.

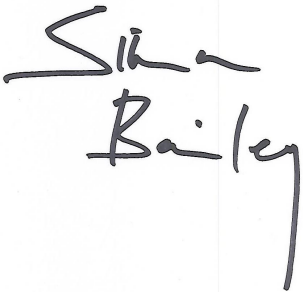
Signature:		
Name:	A M Winning	S Bailey
Title:	Lead Product Assessor	Senior Product Assessor

Appendix A Performance Data

Primary Data

Report No.	Configuration	Leaf Size (mm)	Test Standard	Performance (mins)
FEP/F16174 (Pyroplex Seals)	ULSADD	2140 923/923 54	BS 476: Part 22: 1987	Integrity ¹ : 68
WF374929 (STS seals)	B: ULSADD	2400 927/582 54		Integrity: 67 Insulation: 67
WF369636	ULSADD	2145 923 54		Integrity: 65 Insulation: 65

Supporting Data

CFR1404291 (10mm Pilkington Pyrodur EW60-10 glass)	B: Fixed Door Leaf (ISL 60 Plus glazing system)	2135 665 64	Principles of BS 476: Part 22: 1987	Integrity: 104
CFR1405131 (11mm Contraflam Door Lite Glass)	B: Fixed Door Leaf (ISL 60 Plus glazing system)	2135 665 64		Integrity: 105
CFR1405201 (6mm Schott Pyran S glass)	A: Fixed Door Leaf (Sealmaster Fireglaze glazing system)	A & B: 2135 665 64		Integrity: 76
	B: Fixed Door Leaf (ISL60 Plus glazing system)		Integrity: 93	
CFR1603041 (Blue60 fire-stopping foam and packers)	LSADD	2400 1000/1000 44	BS EN 1634-1	Integrity: 64

- In accordance with section 8.6.1 of BS476: Part22: 1987, the specimen has not been evaluated for insulation. Glass tested was Pilkington Group Ltd, Pyrodur EW60-10. Based on the performance recorded in the test it is our opinion that glass types known to have better or similar insulation performance may be utilised, up to maximum of 16mm thick as assessed in section 7. Glazed area was 0.616m². Based on internal assessment rules, a maximum glazed area of 1.1m² is permitted, subject to the requirements of section 7
- Tests CFR1404291, CFR1405131 & CFR1405201 utilised 64mm thick timber based Falcon Strebord FD90 door blanks, it is our assessment that this test data may be used as supporting data to permit the use of the tested glazing systems within the Strebord 60 minute doorset design. The Strebord 60 minute design has been successfully tested with glazed apertures of greater area, assessment of the ISL 60 Plus and Sealmaster Fireglaze systems will limit the assessed area based on those tested within CFR1404291, CFR1405131 & CFR1405201.

Appendix B

60 Minute Proprietary Glazing Systems

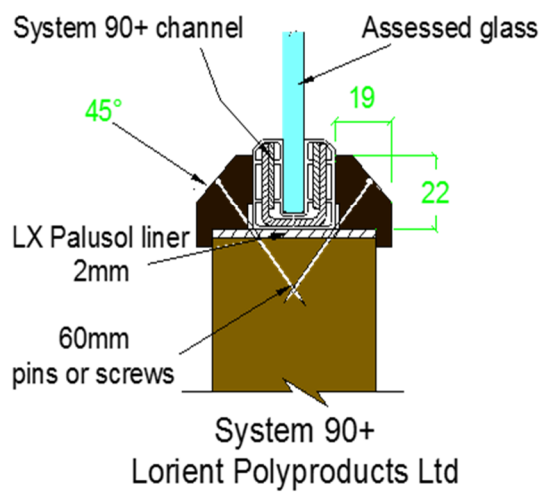
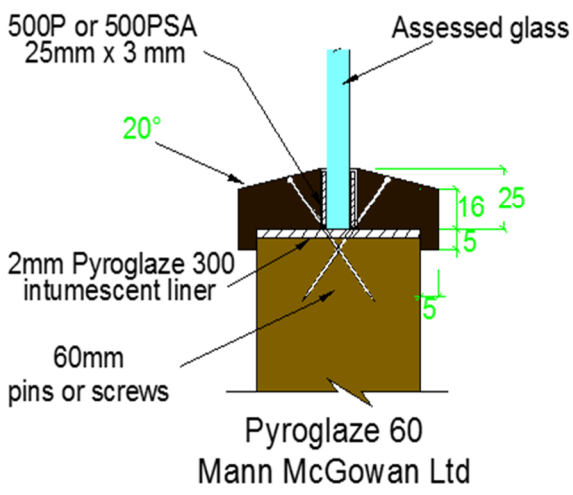
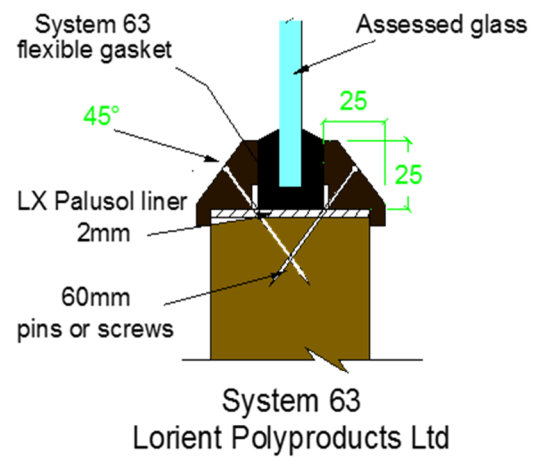
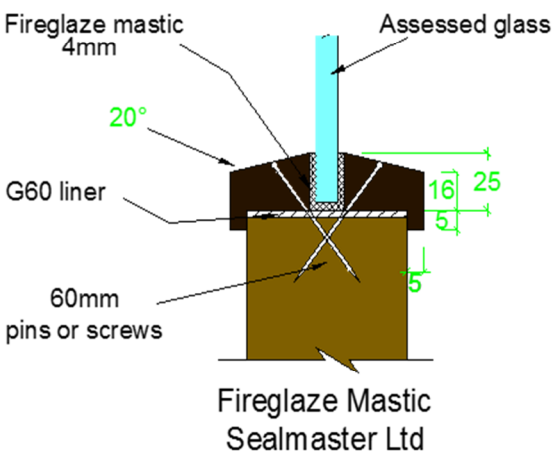
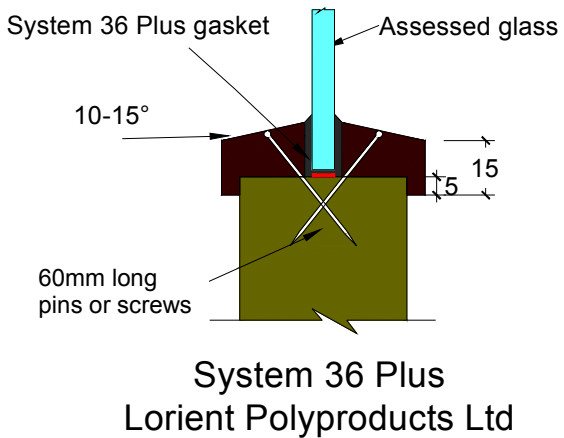
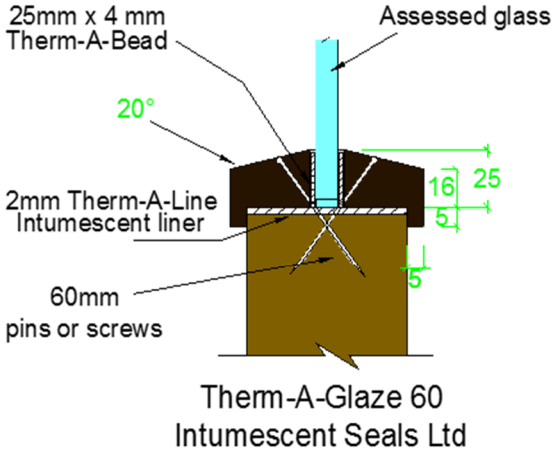

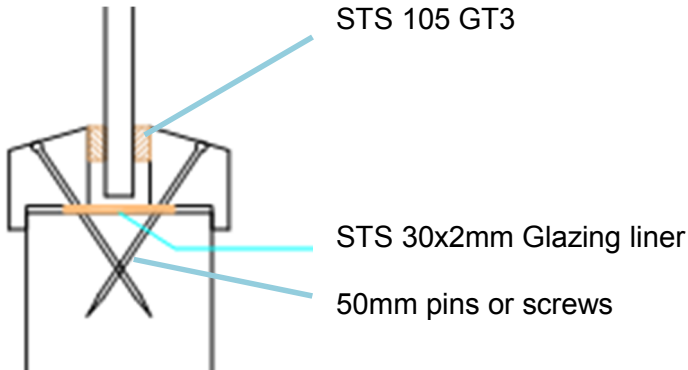

Both bead specifications below may be utilised



Sealmaster Ltd - Fireglaze Tape

60mm long screws

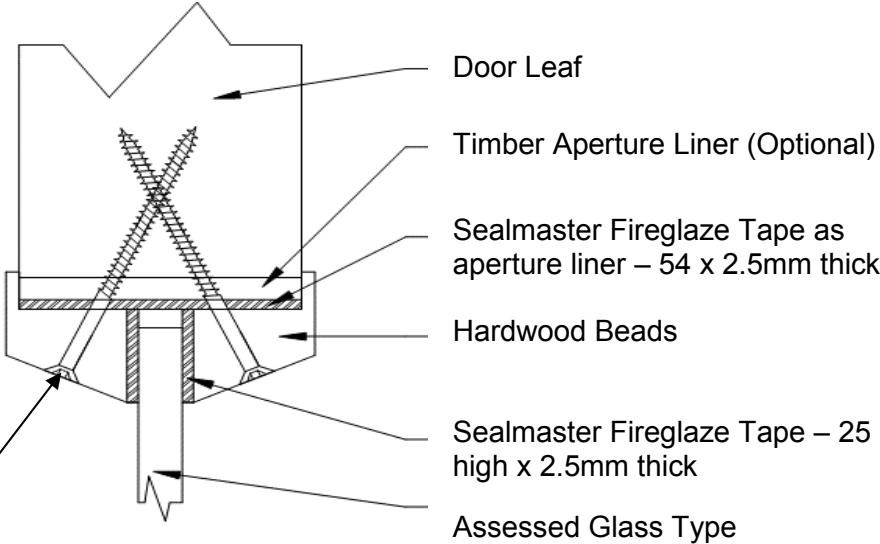

Intumescent Seals Lt- ISL60 Plus

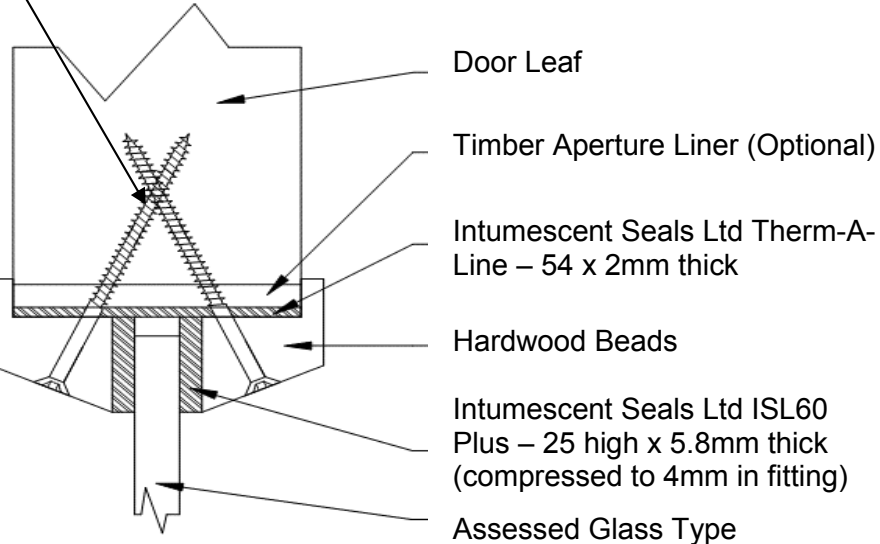

Assessed Square Glazing Bead Profiles

The following square bead profiled may be used as an alternative to the splayed beads detailed above – refer to section 7.4 for glazing system and glass restrictions. Provided any prescribed dimensions are complied with, including the bead splay angle, any bead shape is permitted; refer to section 7 for glass installation requirements.

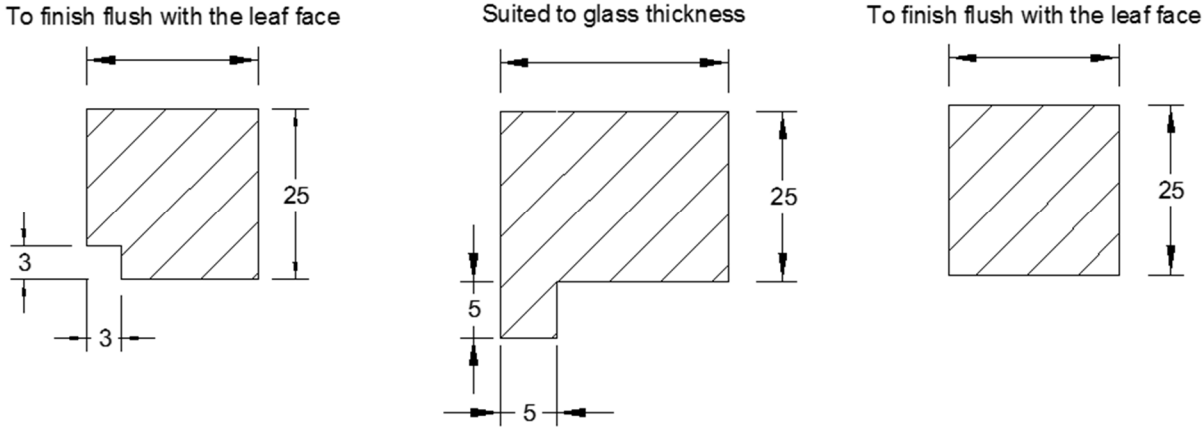

Appendix C
Revisions

Rev.	Ref.	Date	Description

Appendix D

Date Sheets for:

**Falcon Panel Products Ltd.
Stredor Doorsets**

60 Minutes Fire Resistance

Falcon Panel Products Ltd. Stredor Doorsets – 60 Minutes Fire Resistance
Latched & Unlatched, Single & Double Acting, Single Doorsets

Leaf Sizes	Configuration		Height (mm)		Width (mm)
	LSASD	From:	2140	x	1059
		To:	2432	x	923
ULSASD & DASD	From:	2140	x	1034	
	To:	2382	x	923	
Maximum Overpanel Height (mm)		Transomed	2000		
INTUMESCENT MATERIALS: PVC encased Pyroplex Rigid Box Seals – Pyroplex Ltd.					
HEAD: 2No. 15 x 4mm seals fitted 5mm either side of the centreline in the leaf or frame head reveal. For leaves over 2400mm high, increase to 2No. 20 x 4mm seals.					
JAMBS: 2No. 15 x 4mm seals fitted 5mm either side of the centreline in the leaf edge or frame reveal.					
HARDWARE PROTECTION: See section 12.					

Maximum Door Leaf Size

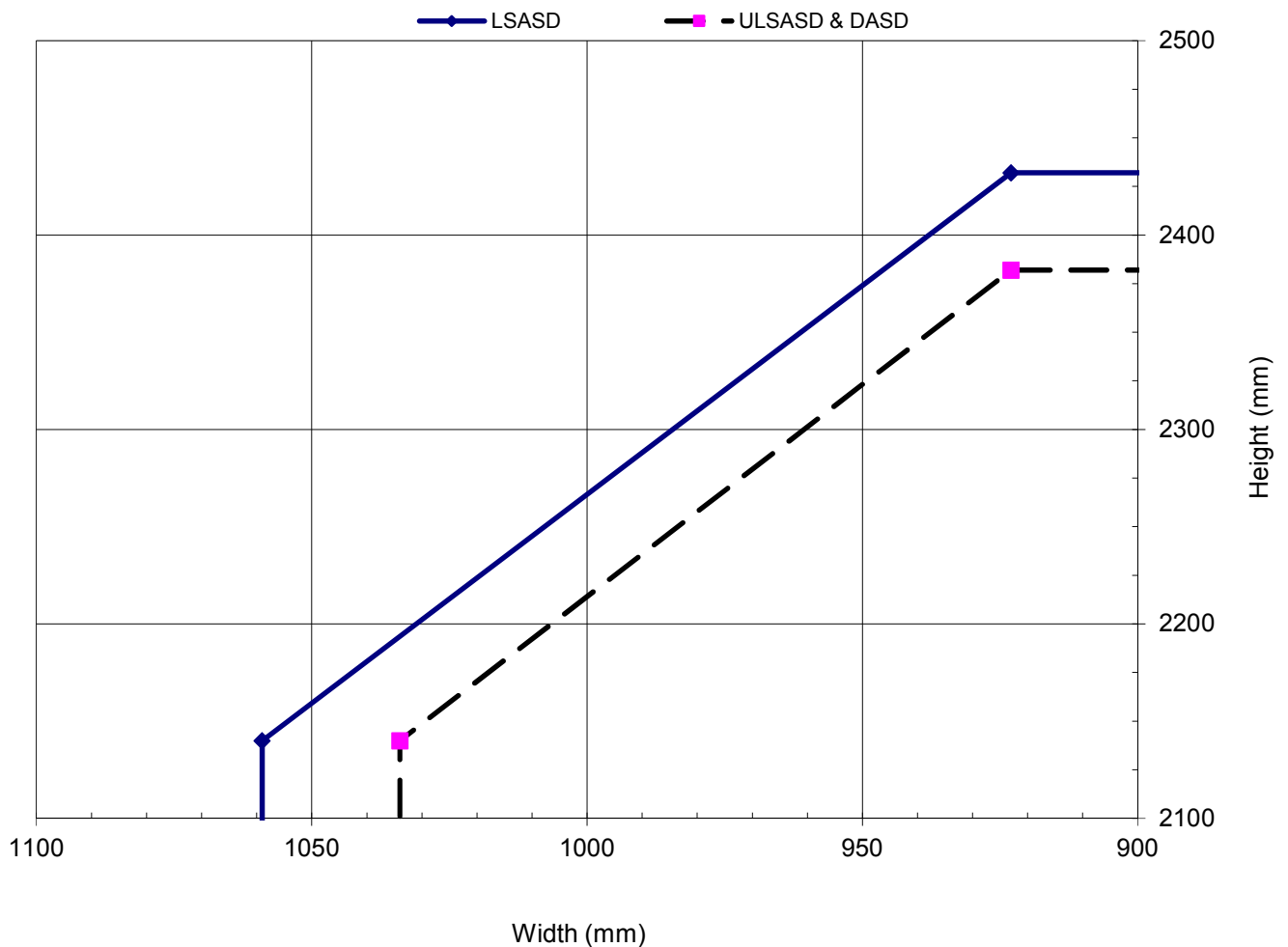

Falcon Panel Products Ltd. Stredor Doorsets – 60 Minutes Fire Resistance
Latched & Unlatched, Single & Double Acting, Single Doorsets

Leaf Sizes	Configuration	Height (mm)		Width (mm)	
	LSASD	From: To:	2400 2690	x x	1056 927
	ULSASD & DASD	From: To:	2400 2640	x x	1031 927
		Maximum Overpanel Height (mm)	Transomed	2000	

INTUMESCENT MATERIALS: ST1504 – Sealed Tight Solutions Ltd.

HEAD: 2No. 15 x 4mm seals fitted 5mm either side of the centreline in the leaf or frame head reveal.

JAMBS: 2No. 15 x 4mm seals fitted 5mm either side of the centreline in the leaf edge or frame reveal.

HARDWARE PROTECTION: See section 12.

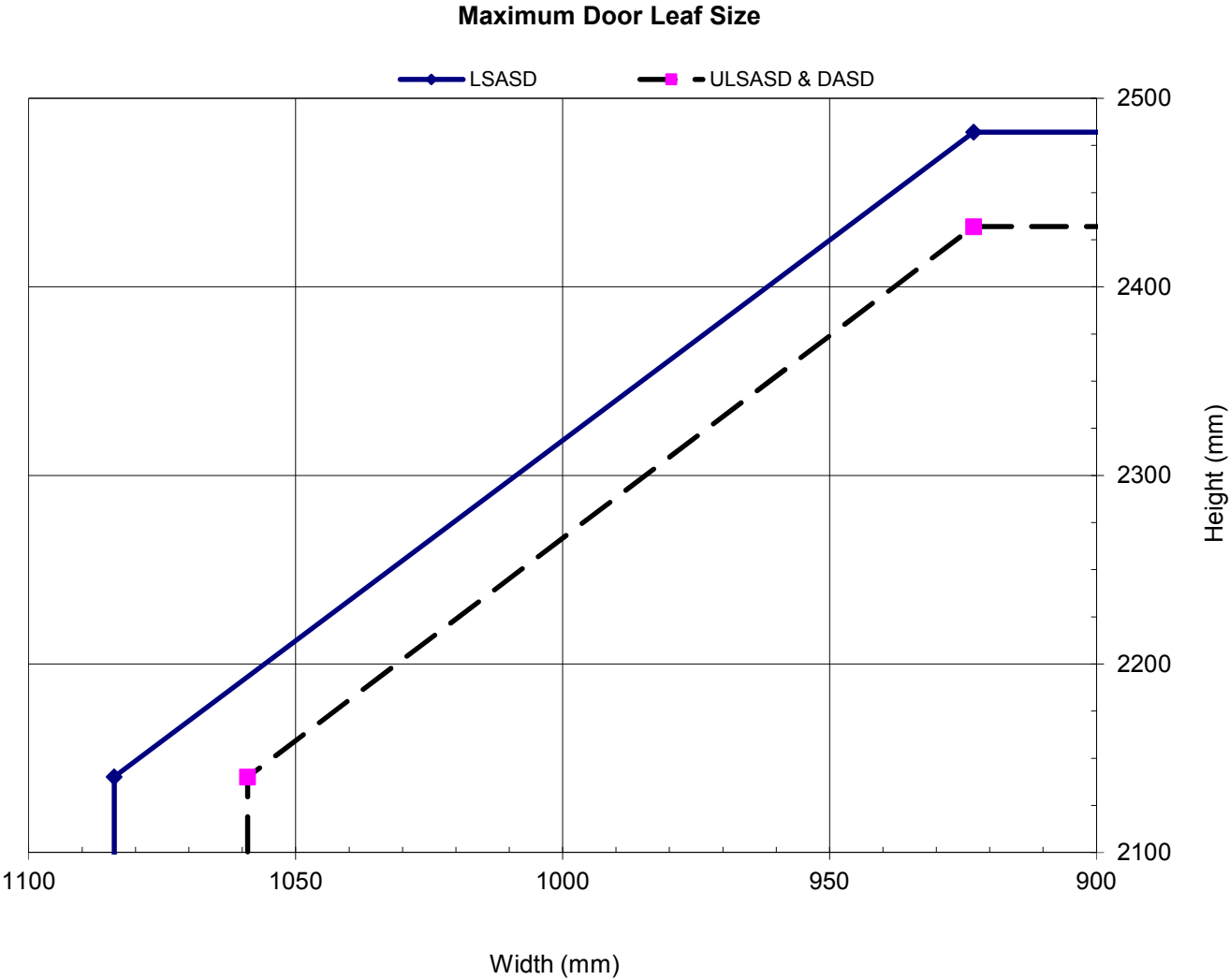

Falcon Panel Products Ltd. Stredor Doorsets – 60 Minutes Fire Resistance
Latched & Unlatched, Single & Double Acting, Double Doorsets

Leaf Sizes	Configuration		Height (mm)		Width (mm)
	LSADD	From: To:	2140 2332	x x	1009 923
ULSADD & DADD	From: To:	2140 2282	x x	984 923	
	Maximum Overpanel Height (mm)	Transomed	1500		

INTUMESCENT MATERIALS: PVC encased Pyroplex Rigid Box Seals – Pyroplex Ltd.

HEAD:
 2No. 15 x 4mm seals fitted 5mm either side of the centreline in the leaf or frame head reveal.

JAMBS: 2No. 15 x 4mm seals fitted 5mm either side of the centreline in the leaf or frame head reveal.

MEETING EDGES:
Square: 2No. 15 x 4mm seals fitted centrally 5mm either side of the centreline in one meeting edge only.

HARDWARE PROTECTION: See section 12.

Maximum Door Leaf Size

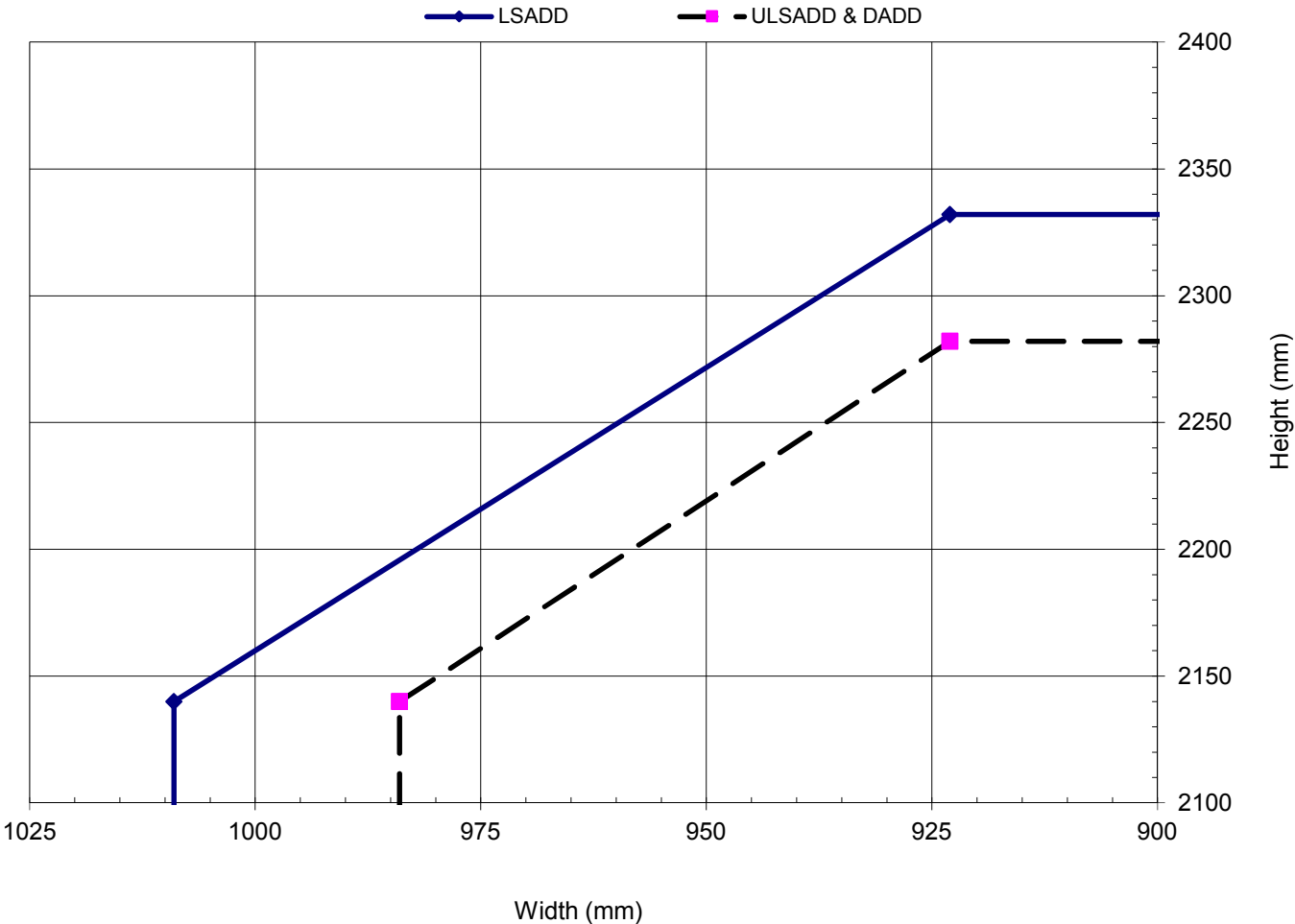

Falcon Panel Products Ltd. Stredor Doorsets – 60 Minutes Fire Resistance
Latched & Unlatched, Single & Double Acting, Double Doorsets

Leaf Sizes	Configuration		Height (mm)		Width (mm)
	LSADD	From: To:	2400 2590	x x	1006 927
ULSADD & DADD	From: To:	2400 2540	x x	981 927	
	Maximum Overpanel Height (mm)	Transomed	1500		

INTUMESCENT MATERIALS: ST1504 – Sealed Tight Solutions Ltd.

HEAD:
 2No. 15 x 4mm seals fitted 5mm either side of the centreline in the leaf or frame head reveal.

JAMBS: 2No. 15 x 4mm seals fitted 5mm either side of the centreline in the leaf or frame head reveal.

MEETING EDGES:
Square: 2No. 15 x 4mm seals fitted centrally 5mm either side of the centreline in one meeting edge only.

HARDWARE PROTECTION: See section 12.

Maximum Door Leaf Size

